

## AERIAL WORK PLATFORM SPIDER 15.70 E - ED - EB - D - B

*Translation of the original instructions*

Logbook code: **4998510200.0**

Version: **11/2022**

Edition: **03/2025**



### **Caution**

Before proceeding with all operations, it is necessary to read and understand this manual in all its parts. Keep the handbook in a safe place where it is easily accessible for consultation.



Builder:	PLATFORM BASKET s.r.l.
Address:	Via Montessori, 1 - 42028 Poviglio (RE) - Tel: +39 0522967666 - Fax: +39 0522967667 www.platformbasket.com
Document type:	<b>OPERATING AND MAINTENANCE MANUAL</b>
Model:	Spider 15.70 E - ED - EB - D - B
Serial number:	
Client:	
Year of manufacture:	

**The contents of the present document cannot be used, reproduced or transferred to third parties without the express permission of builder.**

**The builder reserves the right to change the characteristics of the machine described in the present document without notice.**



## SUMMARY

### 1. GENERAL INFORMATION

- 1.1. INTRODUCTION
- 1.2. WARRANTY
- 1.3. INTRODUCTION
- 1.4. HOW TO CONSULT THE MANUAL
  - 1.4.1. TOPICS NOT COVERED BY THE MANUAL
  - 1.4.2. HOW TO READ THE DIRECTIONS FOR USE
- 1.5. INTENDED USE
- 1.6. IMPORTANT NOTES
  - 1.6.1. USER OR MACHINE OPERATOR
  - 1.6.2. BUILDER
  - 1.6.3. CHECKING THE SUPPLIED PRODUCT
- 1.7. MISUSE
- 1.8. SYMBOLS UTILISED
- 1.9. GLOSSARY

### 2. DESCRIPTION

- 2.1. NAMEPLATE
- 2.2. APPLIED SIGNALS
  - 2.2.1. MAIN SAFETY SIGNALS
  - 2.2.2. INFORMATION SIGNALS
  - 2.2.3. BASKET SAFETY SIGNALS
  - 2.2.4. MULTILINGUAL SAFETY SIGNALS
  - 2.2.5. SPECIFIC SAFETY SIGNALS FOR E - ED - EB VERSIONS
  - 2.2.6. ANSI SIGNAGE
- 2.3. MAIN COMPONENTS
- 2.4. ORIENTATION
- 2.5. MACHINE CONDITIONS
  - 2.5.1. PRODUCTION PAUSE
  - 2.5.2. PROLONGED SHUTDOWN
  - 2.5.3. MOMENTARY STOP
  - 2.5.4. WORKING CONDITIONS
  - 2.5.5. MACHINE RETRACTED
  - 2.5.6. MACHINE STABILISED
  - 2.5.7. MACHINE PARKED IN A MINIMUM SPACE CONFIGURATION

### 3. TECHNICAL SPECIFICATIONS

- 3.1. TECHNICAL GENERAL SPECIFICATIONS
- 3.2. OVERALL DIMENSIONS
- 3.3. OUTRIGGING DIMENSIONS
- 3.4. POSITIONING DIMENSIONS
- 3.5. WORKFLOW DIAGRAM
- 3.6. WORKFLOW DIAGRAM

### 4. SAFETY

- 4.1. GENERAL SAFETY RULES
- 4.2. GENERAL PREPARATION
- 4.3. MAKING READY FOR USE
- 4.4. INSPECTIONS TO BE DONE ROUTINELY AND ON RECEIPT
  - 4.4.1. FRAME
  - 4.4.2. TURRET
  - 4.4.3. BOOMS
  - 4.4.4. BASKET
  - 4.4.5. STABILISER
  - 4.4.6. JIB
- 4.5. BOLT AND SCREW TIGHTENING
- 4.6. DAILY VISUAL INSPECTION
- 4.7. DAILY WORKING CHECKS
- 4.8. GENERAL INSPECTION
  - 4.8.1. MAINTENANCE OF THE BATTERIES

- 4.8.2. ELECTRIC PUMP MAINTENANCE
- 4.9. QUALIFICATION OF OPERATING PERSONNEL
- 4.10. PERSONNEL TRAINING
- 4.11. OPERATOR TRAINING
- 4.12. TRAINING SUPERVISION
- 4.13. OPERATOR'S RESPONSIBILITIES
- 4.14. WORKING CLOTHES
- 4.15. WORKING AND TRANSIT AREA
  - 4.15.1. OPERATING POSITIONS
- 4.16. CONTROLS
  - 4.16.1. EMERGENCY STOP
- 4.17. RESIDUAL RISKS AND RULES OF CONDUCT
- 4.18. PERSONAL PROTECTIVE EQUIPMENT (PPE)
- 4.19. METHOD USED TO ACCESS HAZARDOUS AREAS
- 4.20. SAFETY REGULATIONS FOR MACHINE MAINTENANCE
  - 4.20.1. CONSULTATION OF TECHNICAL DOCUMENTS
- 4.21. REPLACEMENT PARTS

## **5. CONTROLS**

- 5.1. GROUND CONTROL PANEL
- 5.2. REMOTE CONTROL
- 5.3. HYDRAULIC DISTRIBUTOR ENABLING DIVERTER - MANUAL PUMP (TO USE IN EMERGENCY CONDITIONS)
- 5.4. CARRIAGE MOVEMENT MANUAL COMMANDS (TO USE IN EMERGENCY CONDITIONS)
- 5.5. AERIAL PART EMERGENCY CONTROLS
- 5.6. OTHER COMMANDS IN THE CAGE
- 5.7. AIR/WATER UTILITIES IN BASKET
- 5.8. ELECTRIC CURRENT IN THE BASKET (OPTIONAL)
- 5.9. WORK LAMP (OPTIONAL)
- 5.10. CONTROLS AND INSTRUMENTS ON BOARD THE MACHINE
- 5.11. DISPLAY
  - 5.11.1. DESCRIPTION AND USE OF THE KEYS
  - 5.11.2. SEQUENCES OF SCREENSHOTS
  - 5.11.3. MESSAGES LIST

## **6. DEVICES**

- 6.1. SAFETY DEVICES
  - 6.1.1. BASKET LOADING CELL (SQ43)
  - 6.1.2. STABILISER FEET GROUND PRESSURE SENSORS (SQ121- SQ122 - SQ123 - SQ124)
  - 6.1.3. MICROSWITCH DETECTING THE PUSHBUTTON PANEL IN THE BASKET (SQ49)
  - 6.1.4. HORN (HA85)
  - 6.1.5. OPTICAL WARNING DEVICE (LUMINOUS COLUMN)
  - 6.1.6. EMERGENCY BUTTON
  - 6.1.7. INCLINATION CONTROL
  - 6.1.8. MANUAL EMERGENCY PUMP
  - 6.1.9. SUPERSTRUCTURE SENSOR RESTING
  - 6.1.10. ROTATION CHECK

## **7. OPTIONAL**

- 7.1. ACCESSORIES AVAILABLE UPON REQUEST

## **8. TRANSPORT**

- 8.1. FOREWORD
- 8.2. SAFETY PRESCRIPTIONS FOR TRANSPORT AND HANDLING OPERATIONS
- 8.3. FASTENING THE MACHINE FOR TRANSPORT ON THE VEHICLE
- 8.4. LOADING AND UNLOADING BY RAMP
- 8.5. LIFT

## **9. USE**

- 9.1. FOREWORD
- 9.2. RADIO CONTROL ACTIVATION
- 9.3. REMOTE CONTROL HARDWARE MANAGEMENT
- 9.4. START/STOP ENGINE
  - 9.4.1. STARTING THE PETROL ENGINE
  - 9.4.2. TURNING THE PETROL ENGINE OFF
  - 9.4.3. STARTING THE DIESEL ENGINE

- 9.4.4. TURNING THE DIESEL ENGINE OFF
- 9.4.5. STARTING THE ELECTRIC MOTOR
- 9.4.6. TURNING THE ELECTRIC MOTOR OFF
- 9.5. STABILISING THE MACHINE
- 9.6. STABILISATION CLOSING
- 9.7. AERIAL PART MOVEMENT (OPENING)
- 9.8. AERIAL PART MOVEMENT (CLOSING)
- 9.9. AUTOMATIC STABILISATION ENABLING
- 9.10. AUTOMATIC STABILISATION RETURN
- 9.11. TRACK EXTENSION/RETRACTION
- 9.12. SHIFTING
- 9.13. TRANSFORMING THE PUSHBUTTON PANEL FROM RADIO CONTROL TO WIRE CONTROL
  - 9.13.1. CONTROL STATION AND GROUND CONTROL
- 9.14. REPLACING THE PUSHBUTTON PANEL ACCUMULATOR
- 9.15. CAGE RELEASE/ATTACHMENT
- 9.16. CAGE POSITIONING FOR WORK AND TRANSPORT
- 9.17. MOVEMENTS IN AN EMERGENCY
  - 9.17.1. CONDITION 1 – SITUATION WHERE THERE IS: FAULT WITH THE PUMPS/MAIN ENGINES WITH ACTIVE ELECTRICAL CONTROL PART
  - 9.17.2. CONDITION 2 – SITUATION WHERE THERE IS: NO OPERATION OF THE CONTROL SYSTEM FROM THE BASKET OR WHERE THE OPERATOR IS TAKEN ILL IN THE BASKET
  - 9.17.3. CONDITION 3 – SITUATION WHERE THERE IS: FAULT WITH THE MAIN ELECTRICAL SYSTEM AND IT IS POSSIBLE TO START UP THE PUMPS/MAIN ENGINES
  - 9.17.4. CONDITION 4 – SITUATION WHERE THERE IS: FAULT WITH THE MAIN ELECTRICAL SYSTEM AND IT IS IMPOSSIBLE TO START UP THE PUMPS/MAIN ENGINES

## **10. TROUBLES - CAUSES - REMEDIES**

- 10.1. FOREWORD
  - 10.1.1. TECHNICAL ASSISTANCE
- 10.2. MAINS DEFECTS

## **11. MAINTENANCE**

- 11.1. FOREWORD
- 11.2. MAINTENANCE WORK SAFETY
- 11.3. ROUTINE MAINTENANCE FREQUENCY TABLE (CLEANING)
- 11.4. ROUTINE MAINTENANCE FREQUENCY TABLE (LUBRICATION)
- 11.5. ROUTINE MAINTENANCE FREQUENCY TABLE (MECHANICAL MAINTENANCE)
- 11.6. ROUTINE MAINTENANCE FREQUENCY TABLE (ELECTRICAL MAINTENANCE)
- 11.7. ROUTINE MAINTENANCE FREQUENCY TABLE (FUNCTIONING TESTS) <sup>(1)</sup>
- 11.8. CLEANING
  - 11.8.1. CLEANING THE DATAPLATES AND INDICATOR LIGHTS
- 11.9. GREASING
  - 11.9.1. GREASING POINTS DIAGRAM
- 11.10. LUBRICATION
- 11.11. CHECKING THE LEVEL AND REPLACING THE HYDRAULIC OIL
  - 11.11.1. CHECK
  - 11.11.2. CHANGE
- 11.12. LUBRICANTS TABLE
- 11.13. REPLACE PRESSURE FILTER CARTRIDGES
  - 11.13.1. CLEANLINESS/REPLACEMENT OF THE RETURN FILTER
- 11.14. CHECKING AND TENSIONING THE TRACKS
- 11.15. CHECKING FOR WEAR AND WEAR PAD ADJUSTMENT
- 11.16. CHECK THE COMBUSTION ENGINE STARTER BATTERY
- 11.17. CHECK TIGHTENING
- 11.18. SCREW TIGHTENING
  - 11.18.1. SCREW TIGHTENING TABLE
    - 11.18.1.1. PRE-LOAD AND TORQUE FOR SCREWS WITH ISO THREAD AND WIDE PITCH
    - 11.18.1.2. Pre-load and torque for screws with ISO thread and small pitch
- 11.19. CHECKING SENSORS AND MICROSWITCHES
- 11.20. CHECK EMERGENCY BUTTONS
- 11.21. ELECTRICAL MAINTENANCE
  - 11.21.1. FUSE REPLACEMENT
- 11.22. PLACING THE MACHINE OUT OF SERVICE FOR A PROLONGED PERIOD OF DISUSE
- 11.23. ANNUAL OPERATING TESTS

**12. SCRAPPING AND DISPOSAL**

12.1. WARNING

**13. LOG OF THE OPERATIONS DONE ON THE MACHINE**

13.1. MAINTENANCE RECORDS AND LOGBOOK

13.1.1. MAINTENANCE RECORDS

**14. ENCLOSED DOCUMENTATION**

14.1. HYDRAULIC SYSTEM

14.2. ELECTRICAL SYSTEM

14.3. CE CONFORMITY DECLARATION

## 1. GENERAL INFORMATION

### 1.1. INTRODUCTION

Dear customers,

**PLATFORM BASKET S.r.l.** thanks you for your choice.

Your new access equipment is the result of an innovative approach and the pursuit of quality.

It has been designed to be functional, safe, comfortable and durable with style and excellent operating features.

When your machine requires maintenance, only the spare parts supplied by us must be used in order to ensure reliability and suitability.

If you encounter problems or need more information contact our staff directly by calling one of the following numbers or send us an e-mail.

Phone **+39 0522 967666**

Fax **+39 0522 967667**

Company e-mail **info@platformbasket.com**

After-sales-mail **assistenza@platformbasket.com**

WEB **www.platformbasket.com**

Best regards.

### 1.2. WARRANTY

For the warranty conditions, refer to that stated in the sales contract (in this way "they can be customised").

### 1.3. INTRODUCTION

As our products are always in change (as components of our suppliers) some details could not match exactly those installed on Your machine type.

In such cases, if you are in doubt with regard to the correct operation, consult an authorised service centre.

Never proceed by trial and error.



#### Note

For the intervention requests (also by telephone), it is important for the manufacturer to know the number of machine working hours (indicated by the timer) and the serial number.

Make sure you have this information on hand before making an intervention request.

In order to always give a better product, report errors or omissions of the manuals provided, in particular situations involving safety, recommendations for improving the machine and our aftersales service or anything else you would like to communicate.

**This manual lists information relating to the model only:**

– **SPIDER 15.70 E - ED - EB - D - B**



#### Note

Italian is declared the official language.



#### Caution

In this publication, the term machine refers to the **SPIDER 15.70** elevating platform.



#### Note

The company **PLATFORM BASKET S.r.l.** is referred to as the Manufacturer.

## 1.4. HOW TO CONSULT THE MANUAL

### 1.4.1. TOPICS NOT COVERED BY THE MANUAL

This publication DOES NOT address the following subjects:

- Maintenance or non-routine interventions.  
Non-routine maintenance tasks must be performed by personnel specifically authorised by the manufacturer.
- The installation and disassembly of the machine or its function units.  
This procedure is to be carried out by authorised personnel, trained as necessary by the Manufacturer.

### 1.4.2. HOW TO READ THE DIRECTIONS FOR USE

The handbook is divided in chapters, each of which describes a specific category of information.

Each operator who interacts with the machine, apart from reading all the documentation, must read and learn the information concerning his specific qualification.

Refer to the name preceding the title of the chapters, present in the summary, to search for the subjects to consult.

*These instructions are the result of an automatic system of assembly of text and illustrations, therefore, it is possible to find, as pages change, some interruptions of the flow of text and charts.*

**Keep this manual for the entire duration of its useful life in a well known and easy to access place, available for reference any time the need should arise.**

Keep the instructions for use and the attached documentation for future consultation.

## 1.5. INTENDED USE

In compliance with the machinery directive **2006/42/CE**, these machines must only be entrusted for use by personnel or operators defined as "professional".

Moreover, this staff has to be "qualified" for using the specific machine, through proper "formation and information" (by and to the account of the customer) and through these "Instructions for use" that have to be at disposal of the operator before using the machine.

**The machine has been designed to lift operator (s) with the limits indicated in this publication.**

**The machine must be used and manned by at least 2 operators (one at a height and one on the ground).**

## 1.6. IMPORTANT NOTES



### Caution

- It is forbidden to modify any part of the machine for any reason without explicit written authorisation from the manufacturer.  
None of the manufacturer's agents or representatives is authorised to give instructions that modify the "user instructions in any way, safety prescriptions, the warranty and/ or the way of using the product.
- The manufacturer declines all liability in relation to unauthorised modifications and reserves the right to take any actions it deems necessary to protect its interests.

### 1.6.1. USER OR MACHINE OPERATOR

The professional staff that uses or intervenes on the machine is liable for any damage to himself, third parties or objects deriving from:

- improper use of the machine and any part of the machine.
- failure to comply with the safety prescriptions and safety regulations.

**Use of the machine must be entrusted only to professionally qualified operators.**



#### Caution

A qualified operator is construed as a person who has:

- read the “operating instructions” in their entirety;
- understood the concepts expressed in this publication;
- The licence for suitability of use, if required by the laws in force;
- Participated in the course regarding the standards of use, emergency and maintenance, carried out by an experienced technician, authorised by the owner.



#### Note

If provided, the training course is designed to present the information given in the “Operating instructions” and provide immediate clarification of any doubts, effectively improving the training of operators in compliance with the requirements of statutory legislation.

### 1.6.2. BUILDER

The manufacturer is not responsible for consequences due to an incorrect or inappropriate use of the machine, such as:

- Non conform method of use;
- Use by personnel or operators not enabled;
- Lack of attention in maintenance, in controls during production process and in checking the efficiency of the tools;
- removal or disabling of active and passive safety devices;
- Irresponsible conduct not in compliance with good common practice;
- Unauthorised modifications.

### 1.6.3. CHECKING THE SUPPLIED PRODUCT

On receipt of the supplied product check that the delivered material complies with the order and that the “Operating Instructions” are attached.

When the machine is delivered check it carefully for damage or missing parts.

If you notice signs of damage or missing parts contact the manufacturer or LOCAL AGENT.

When the product is received, in the presence of inconsistencies, missing material, or manifest signs of damage, inform the manufacturer immediately, write your reservations clearly on the delivery note and immediately send a documented report to the shipping agent’s insurance company, complete with photographic evidence of the problem(s).

## 1.7. MISUSE

It is prohibited to use the machine differently to that described in the intended use – general safety standards” chapter.

## 1.8. SYMBOLS UTILISED

Below are the symbols used in this manual which point out to the reader the various levels of danger in the operation and maintenance of the machine.



Information or procedure that, if not carefully carried out, could lead to death or heavy injuries or machine damages.

It is often referred to "residual risks" or, in any case, to dangerous situations.



Information or procedures which advise the operator as to how best to use the machine to prolong its life, avoid damage or loss of programming data, and optimize the work in compliance with the standards.



Ancillary information.

## 1.9. GLOSSARY

### **Staff appointed to use/ operator/user**

In compliance with the harmonized standards, the operator is defined as the person or persons in possession of the requirements, skills and information necessary to guarantee maximum safety during the installation, operation, regulation, maintenance, cleaning, repair and transport of the machine.

### **Lessee**

The person who has rented the self-propelled lifting platform.

The lessee could also be the operator or person appointed for use.

### **Basic assemblage**

Self-propelled lifting platform without optional parts or accessories including machine CE certification.

### **Pivot (synonymous: knuckle)**

Joint and axle of the movement of two elements.

### **Basket levelling**

Manoeuvre that allows to align the deck of the cage with that of the machine frame.

This adjustment is performed by the manufacturer's technicians during the construction of the machine.

### **Service centre**

Place where you can interact with personnel authorised by us for the sale, installation, assistance, testing and marketing of the machinery or spare parts.

### **Authorised service center**

see "service centre".

### **Basket**

See basket.

### **Power system**

System that transmits an energy or force used to move any part on the elevating platform (hydraulic, electrical, pneumatic, etc).

### **Column**

See turret.

### **Command**

Any device (push button, lever, switch, etc.) that starts, regulates or controls the elevating platform.

### **Builder**

Manufacturer of the self-propelled lifting platform.

### **CE Conformity Declaration**

Document issued by the manufacturer to attest the machine's conformity with the machinery directive in force.

**P.P.E.**

Personal Protective Equipment provided under Leg. Decree **81/08** and subsequent amendments.

**Protecting device**

Electrical or mechanical device that prevents accidents and/or damage to property and personal injury; activation of safety devices may be voluntary when performed by an operator or may be caused automatically by the presence of a potential hazard (opening of a protection or access to a certain area).

**Control valve**

Group of commands that manages all or part of the machine drives (movements).

**Telescopic element (synonymous: telescopic extension)**

Two or more hoses which run one into the other, so that the element is lengthening or retractile.

**Solenoid valve**

Valve set in motion electrically.

**Hydraulic extension**

Lengthening or re-entering of an element through a hydraulic movement.

**Telescopic extension**

See extension.

**Heavy-duty**

Lifting platform used at max. allowed limits.

**Levelling (frame)**

Operation performed with stabilisers to position the machine in terms of levelling.

**Levelling the basket**

Movement (automatic or manual) that allows to keep the cage walkway horizontal and parallel with respect to the ground, in any machine work position.

**Machine**

The self-propelled lifting platform complete with power circuits.

**machine retracted**

Status of the machine in which the aerial part extensions are completely retracted and both booms are closed and resting on the booms support (see also **2.5.** "machine status").

The safe machine status is indicated by witching on of the light (**HL89**).

**Routine maintenance**

Operations, planned by the manufacturer for machine checks and maintenance which do not require particular tools or mechanical knowledge.

They are operations such as:

Lubrication, greasing, replacing parts subject to regular wear and the recovery of loosening due to wear.

These operations can be carried out by the machine operator in accordance with the indications shown in this manual with the tools supplied or easily found.

**Non-routine maintenance**

Operations, scheduled and not by the manufacturer, needed to preserve and restore the safety, efficiency and functionality of the machine and also unexpected operations caused by breakage or wear depending on particular events during use. these mandatorily require the intervention of a specialized operator acknowledged as such by the manufacturer in possession of the tools fit for purpose.

**Basket**

Container, connected to the working platform, where one or two operators have their positions, according to the capacity of said platform.

Its purpose is to protect and support operators who need to work at a height.

**Authorised service centre**

The place in which personnel authorised by the manufacturer carry out installation, maintenance, repair, assistance testing operations and the selling of spare parts and accessories.

Sometimes the authorised workshop is also a sales outlet.

**Superstructure**

Group of self-propelled lifting platform components that include, rotation unit, turret, booms, hydraulic extensions, cage and commands that move them.

The moving parts of the machine when the same is in operating configuration.

**Ground part**

Group of components of the self-propelled lifting platform that includes carriage, frame, stabilizers and commands that move them.

The fixed parts of the machine when it is in operating configuration.

**Danger**

Situations or actions that could be the source of possible injury to persons or animals or damage to property.

**Exposed person**

Anyone who is entirely or partly inside a hazardous zone.

**Self-propelled workplatform**

Machine designed to autonomously allow equipped personnel to reach a work area, positioned at a certain height.

**Self-propelled lifting platform**

See self-propelled work platform.

**Hydraulic pump**

Hydraulic component connected to an engine (endothermic or electric), which powers the hydraulic plant.

**Owner**

Natural or legal person, company or body, owner of the self-propelled lifting platform.

**Protection**

Safety measures that consist in the use of specific technical means, designated "protections" (guards, safety devices), to protect persons from potential hazards that cannot be reasonably eliminated or sufficiently restricted by means of design strategies.

**Radius of action/work range**

It is the group of extreme points that can be reached by the self-propelled lifting platform.

**Responsible for safety**

The owner and/or lessee and/or employee who, along with the site manager if operations are performed in areas classified as construction sites, industrial sites and in places with public or private access and in charge of the efficiency and compliance with the standards in force concerning the safety of the self-propelled lifting platform.

**Guard**

Machine element used specifically to guarantee protection through a material barrier.

**Risk**

Combination of the probability and degree of seriousness of possible injury or harm to health in a dangerous situation.

**Extension (widening)**

Distance between the axis of the turret and the external edge of the basket.

**Extensions**

Term used to describe the individual extension components that make up the telescopic element.

**Stabilize**

Basic operation for operating safely, which also includes the choice of the base of operation and the inspection of the stabilisers' support area.

**Turret**

It is the component of the superstructure that allows rotation and supports the machine arms.

**Intended use**

Machine used in compliance with the information provided in the operating instructions.

**Incorrect use that can be reasonably expected**

Machine used in a manner not indicated in the operating instructions, but which could result from human behaviour which may be reasonably expected.

**Danger zone**

Any area inside and/or in the proximity of a machine in which the presence of an exposed person constitutes a risk for the health and safety of such a person.

## 2. DESCRIPTION

### 2.1. NAMEPLATE

The machine identification plate is fixed on one side of the machine.

The following specifications are stamped on the plate:

- 1) Model
- 2) Serial number
- 3) Year of manufacture and other technical data relative to the machine itself.



#### Caution

For any requests covered by the guarantee or for spare parts, indicate the model number **(1)** and the serial number **(2)**.

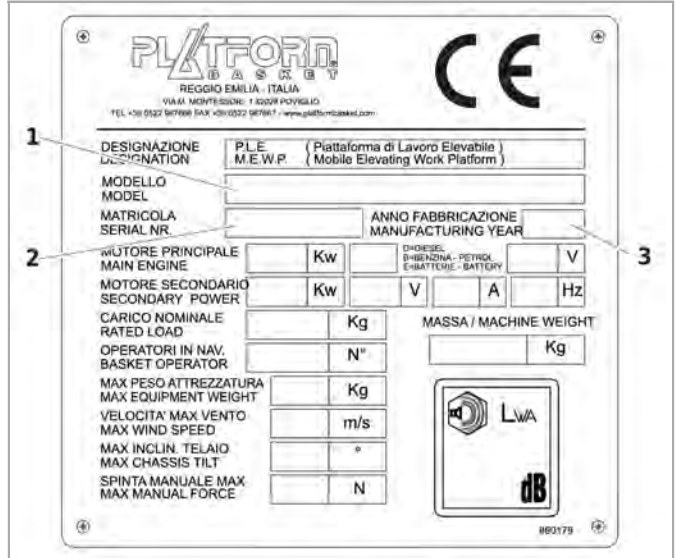

PLATFORM BASKET		CE	
REGGIO EMILIA - ITALIA VIA M. MONTE SIBONE 1 40028 POVELLO TEL +39 0522 967668 FAX +39 0522 967667 - www.platfrombasket.com			
1	DESIGNAZIONE DESIGNATION	PLE M.E.W.P.	(Piattoforma di Lavoro Elevabile) (Mobile Elevating Work Platform)
	MODELLO MODEL		
	MATRICOLA SERIAL NR.		ANNO FABBRICAZIONE MANUFACTURING YEAR
2	MOTORE PRINCIPALE MAIN ENGINE	Kw	D-DIESEL B-BENZINA - PETROL E-BATTERIE - BATTERY V
	MOTORE SECONDARIO SECONDARY POWER	Kw	V A Hz
	CARICO NOMINALE RATED LOAD	Kg	MASSA / MACHINE WEIGHT
	OPERATORI IN NAV. BASKET OPERATOR	N°	Kg
	MAX PESO ATTREZZATURA MAX EQUIPMENT WEIGHT	Kg	
	VELOCITA' MAX VENTO MAX WIND SPEED	m/s	
	MAX INCLIN. TELAIO MAX CHASSIS TILT	°	
	SPINTA MANUALE MAX. MAX MANUAL FORCE	N	
			LWA dB
			#60179

### 2.2. APPLIED SIGNALS



#### Caution

Printed indications may be present on the commercial parts and are the responsibility of the manufacturer of the commercial part.

Its description is not given in the manual.

## 2.2.1. MAIN SAFETY SIGNALS





It is prohibited to walk upon or use as a support surface.

860205



Lifting points.

860145



Wire ropes, belts or chains under strain.  
Points to use to fasten the machine to the means of transport.

860588



Ground pressure.

861450



Tele-diagnostics and gps localisation device.

4959061300



Radio-diagnostic device.

4959061200



Do not use water to extinguish fire on electrical parts.

860087



Danger of projecting or falling objects.

860201



Indicates the position of the **12-24 V** emergency electric pump.

860314



Obligation to read the manual.

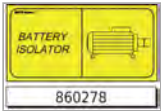

Indicates which elements are protected by the device.  
**ED** version only.

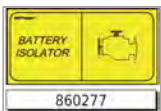

Electric battery isolator.

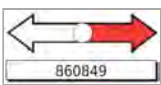

Direction of movement.



Centred column indicators.



Limb crushing risk.



Hook-up point for safety belts.



Electric current service utility outlet **110 V / 230 V / 240 V**.



Indicates caution during handling.  
If present.



Danger of high temperature.

860200

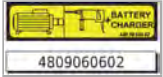

Indicates which elements are protected by the device.

4809060602

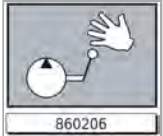

Manual emergency pump.

860206



Danger - Machine is not electrically isolated.

860800



It signals an emergency work station.

860750

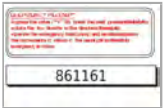

Emergency instructions.

861161



Indicates permission for safety movements.

860364



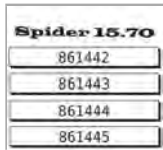

Machine name.



Company name and logo.



Company name and logo.



Work field.  
the sticker shown is purely indicative.

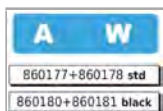

It identifies the fitting for the services.

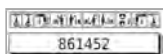

Explains how to operate the levers to get the machine moving on the ground.

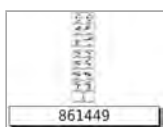

Explains how to operate the levers so as to obtain emergency handling of the superstructure.

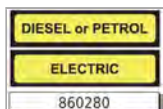

Indicates the motorisation selected and activated informs to which engine the master switch/ battery disconnecter is dedicated.



Identification number of the stabilisers.



They indicate the dimensions of the machine.



Nameplate.

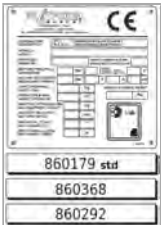

Nameplate.



Indicates the command to overcome the overload condition.



Petrol engine version.



"WCH" version.



Indicates that the platform is not electrically disconnected.

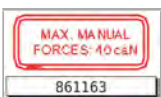

Indicates the maximum applicable pull.

### 2.2.3. BASKET SAFETY SIGNALS

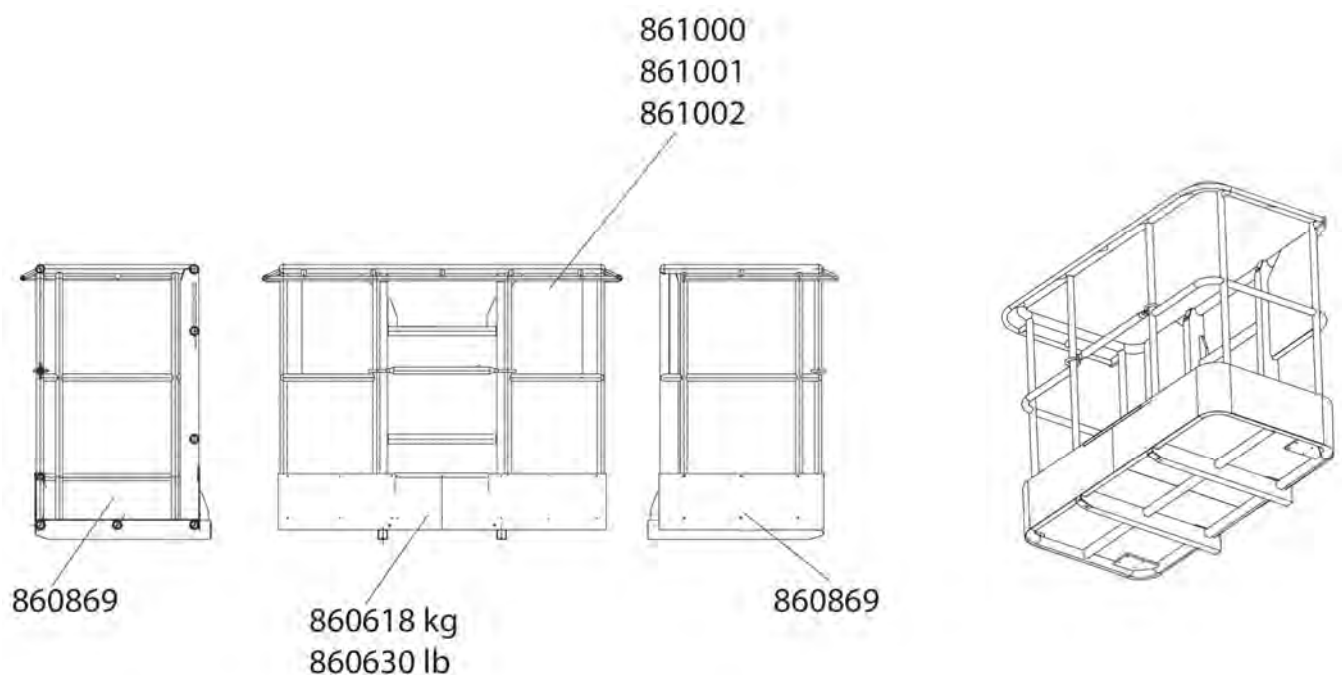



Company name and logo.



Maximum load of the two-seater basket.



Indicates the action to be performed.

## 2.2.4. MULTILINGUAL SAFETY SIGNALS

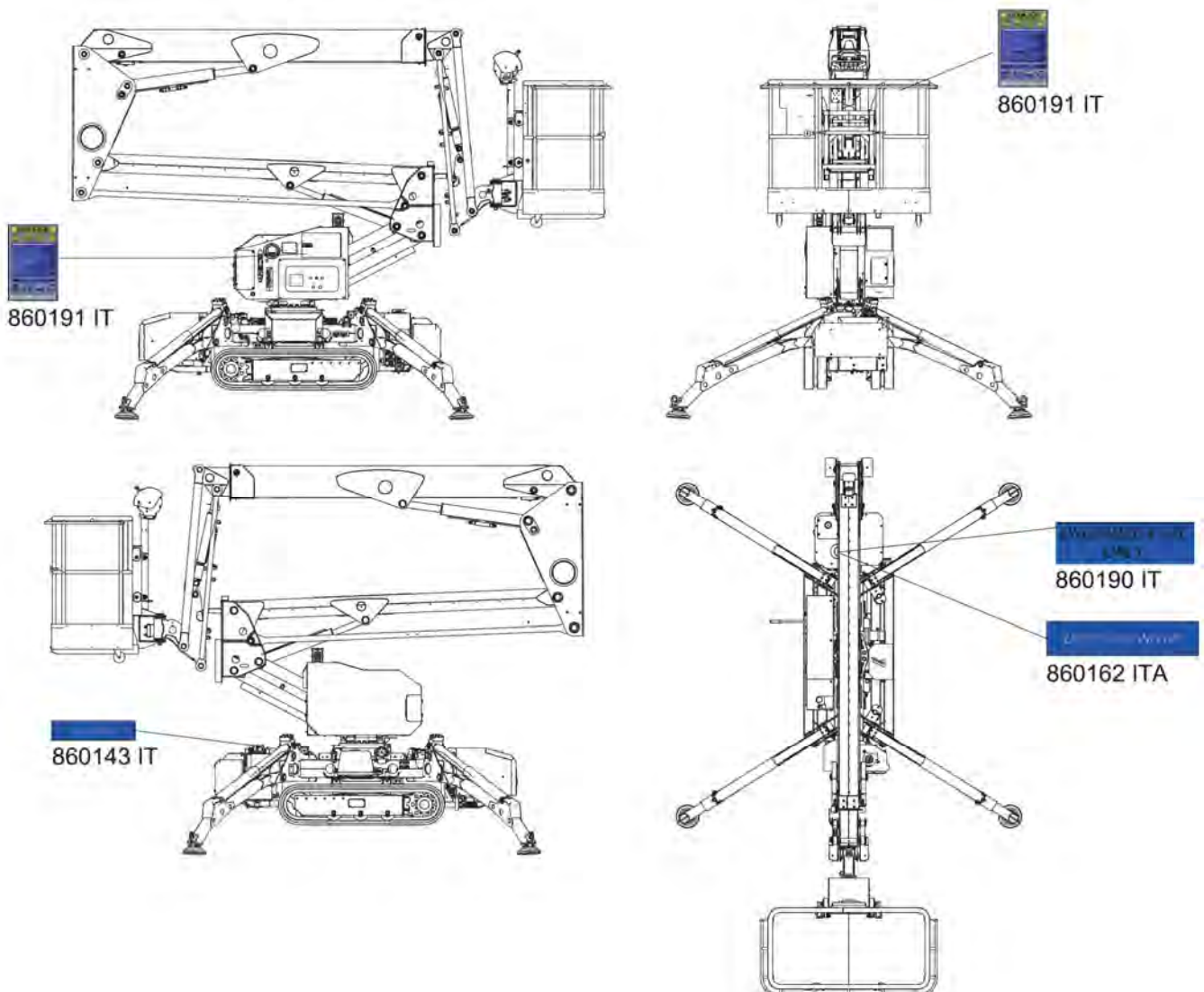

Indicates the filling outlet of a tank and its content.



Danger and caution.



Indicates the filling outlet of a tank and its content.

**2.2.5. SPECIFIC SAFETY SIGNALS FOR E - ED - EB VERSIONS**

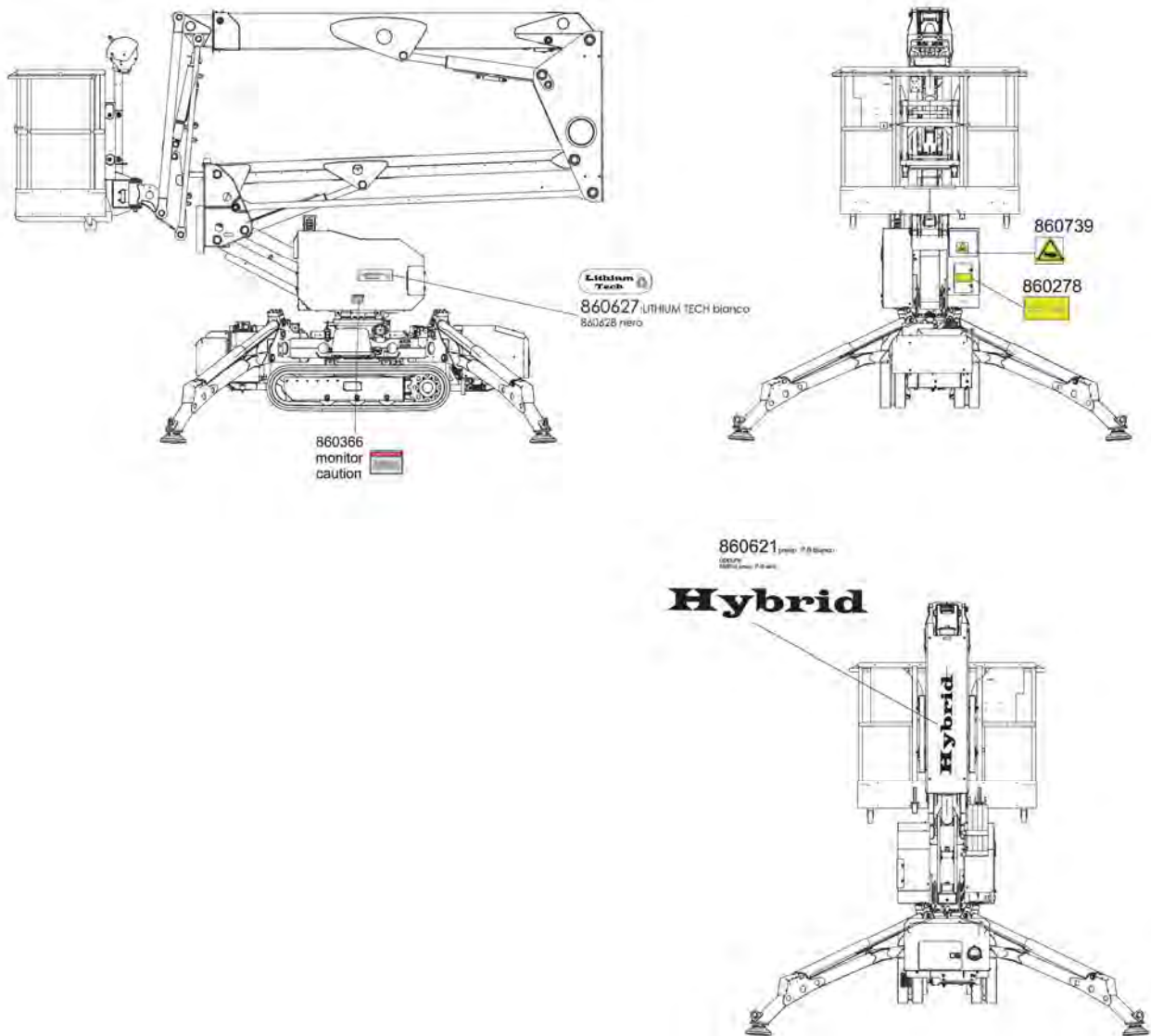

Machine version.



Machine version.



Limb crushing risk.



Do not use water to extinguish fire on electrical parts.

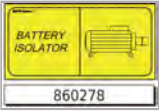

Indicates which elements are protected by the device.



Indicates caution during handling.

## 2.2.6. ANSI SIGNAGE

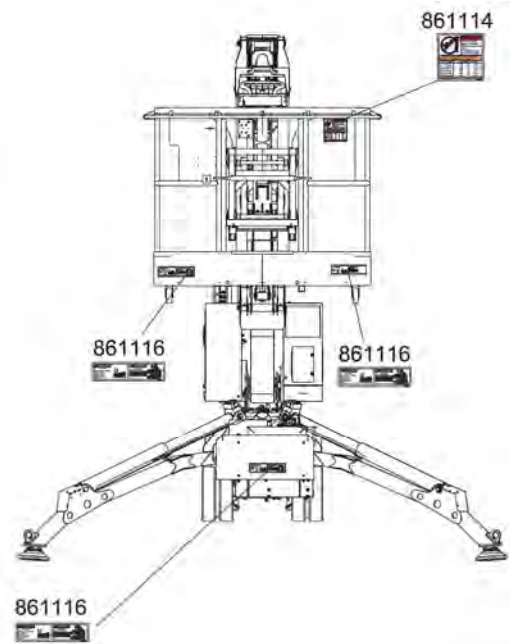
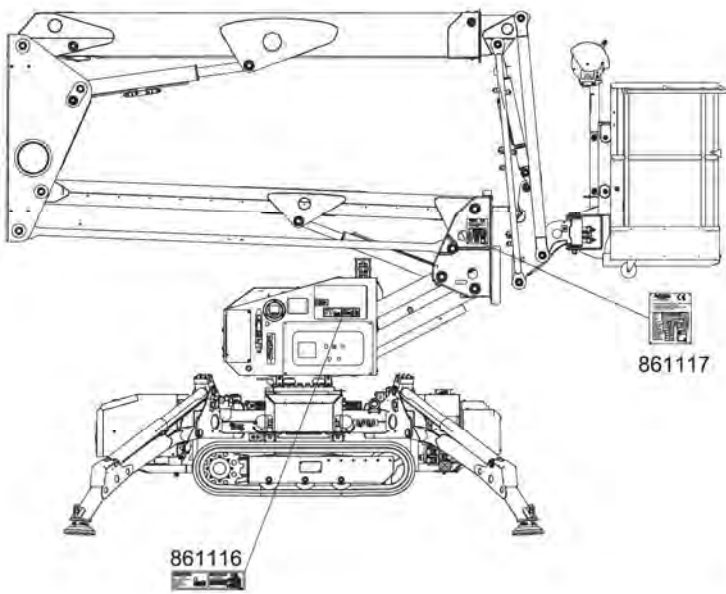

It informs about the maximum permitted inclination of the machine.



High voltage danger.

It indicates the distances to be maintained from high voltage and informs about potential dangers.



Nameplate.

## 2.3. MAIN COMPONENTS

**!** Note

The model illustrated may be slightly different from the model in possession.

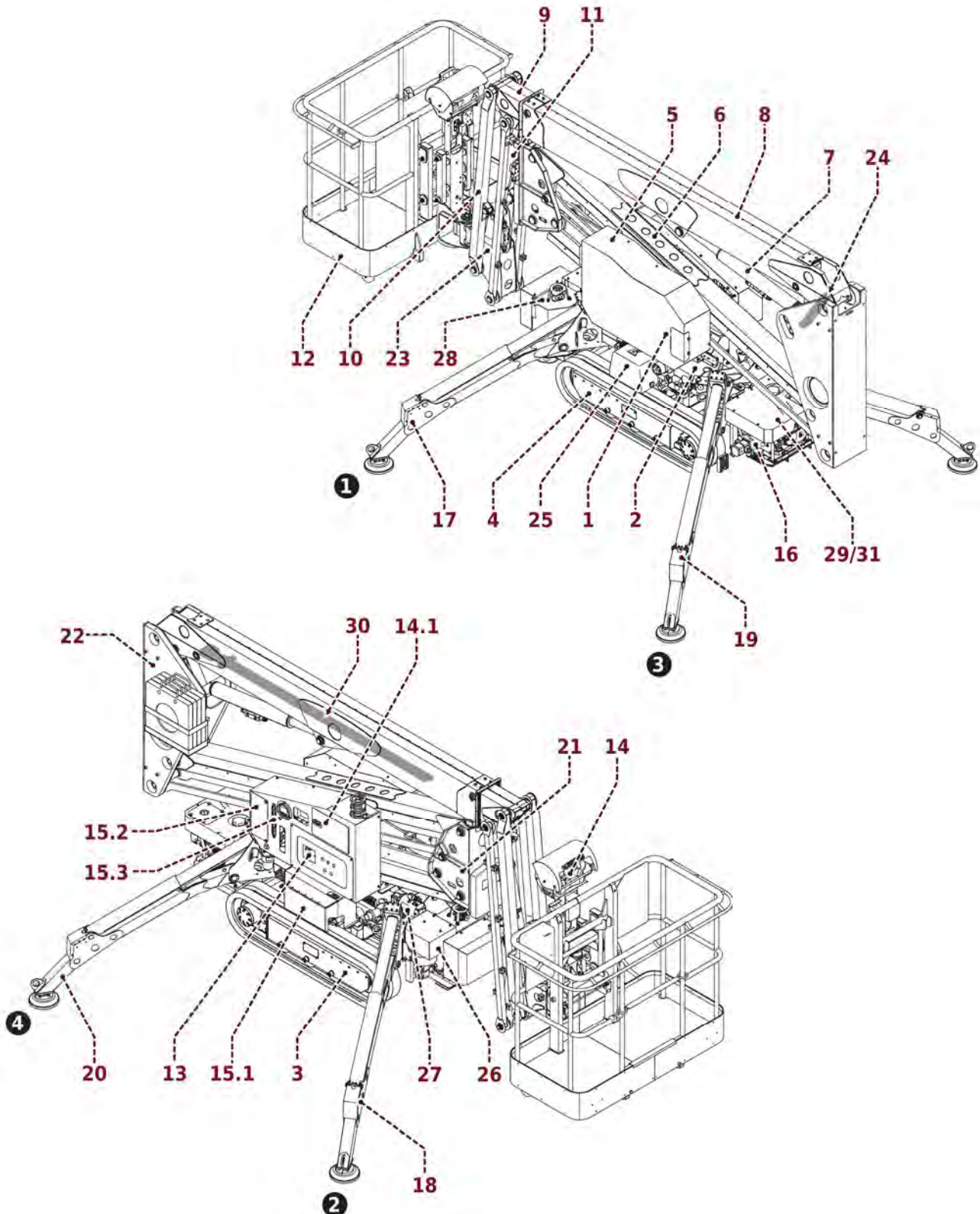

1. Turret
2. Carriage
3. Left track
4. Right track
5. Lower boom lifting cylinder
6. Lower boom
7. Upper boom lifting cylinder
8. Upper boom
9. Upper boom extension
10. Jib
11. Jib articulation cylinder
12. Basket
13. ground controls
14. Remote control
  - 14.1 Remote control compartment housing.
15. Emergency hydraulic commands:
  - 15.1 Manual carriage and stabilizer handling controls
  - 15.2 Manual superstructure handling controls
  - 15.3 Manual pump
16. Engine unit (Internal combustion engine)
17. Rear right stabiliser **(1)**
18. Rear left stabiliser **(2)**
19. Front right stabiliser **(3)**
20. Front left stabiliser **(4)**
21. Pantograph lower head
22. Pantograph upper head.
- 23-24. levelling cylinders (Basket)
25. Diesel engine batteries
26. Electric motor
27. Emergency electric pump (Optional)
28. Hydraulic oil tank
29. Fuel tank (Diesel)
30. Upper boom extension cylinder.
31. Fuel tank (Gasoline).

## 2.4. ORIENTATION

- 1) Upper
- 2) right-hand side
- 3) rear side
- 4) Lower
- 5) left-hand side
- 6) front side

- A) Superstructure  
(slewing ring - column - arms - jib - basket)
- B) Ground part  
(Carriage - undercarriage - stabilizers)

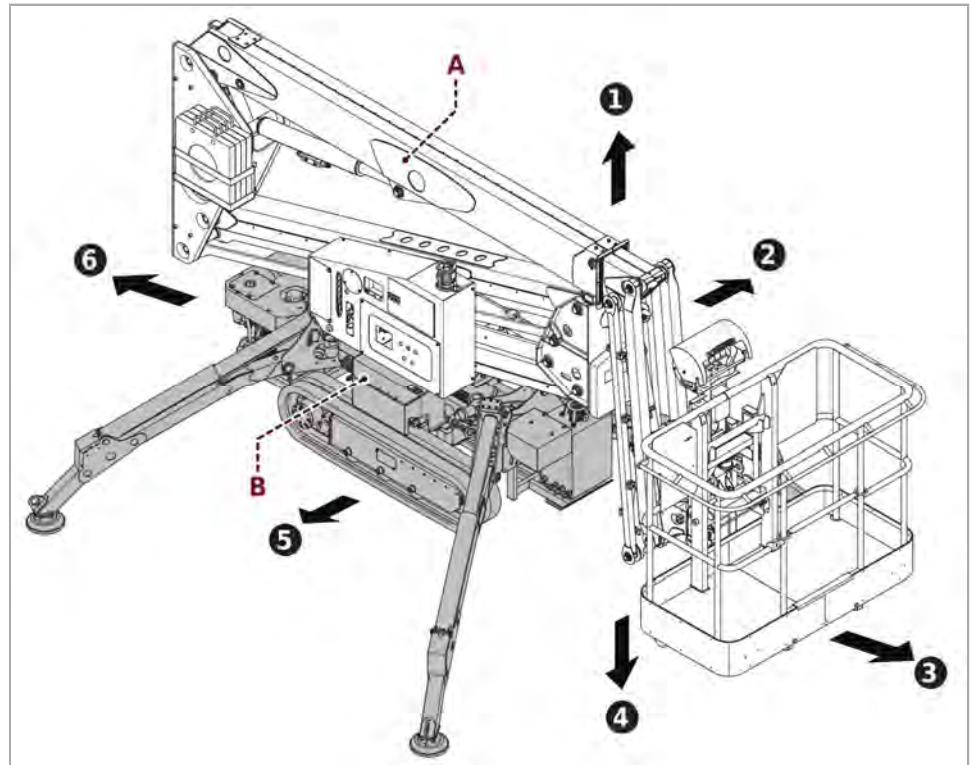

## 2.5. MACHINE CONDITIONS

On restarting the machine after production has been stopped due to any reason, before proceeding check to ensure the machine has not been tampered with.

### 2.5.1. PRODUCTION PAUSE

When the machine is stopped from working for some hours we state that the machine is in configuration of staging work (such as: end of the shift, absence of the operator employed on driving the machine, lunch break).

In the case the general conditions of the machine must be:

- Machine switch-off at main ON/OFF circuit breaker;
- Emergency pushbutton pressed;
- Hatches and panels equipped with locked locks;
- Keys removed;
- The operator can now temporarily leave the machine unmanned;
- The work zone must be delimited and marked.



#### Note

If the operator remains in the area, it is not essential to lock doors and panels equipped with locks.

### 2.5.2. PROLONGED SHUTDOWN

When the machine must remain inoperative for a period of more than **3** days.

E.g. forced absence of the operator assigned to running the machine, closure for holidays, etc.

In the case the general conditions of the machine must be:

- Machine switch-off at main ON/OFF circuit breaker;
- Hatches and panels equipped with locked locks;
- Keys removed;
- Emergency pushbutton pressed;
- Machine cleaned and disconnected from all energy supplies.



#### Note

To prevent discharging the accumulator (battery), it is recommended to disconnect the power supply via the battery disconnecter

- If the maintenance schedule so requires, all the necessary maintenance work must be performed.

### 2.5.3. MOMENTARY STOP

Machine in momentary stop configuration refers to situations in which operation of the machine is suspended for brief periods.

In this case the general conditions of the machine must be as follows.

- Machine switch-off at main ON/OFF circuit breaker.
- Emergency pushbutton pressed.
- Operator present in the machine control station.
- The work zone must be delimited and marked.

### 2.5.4. WORKING CONDITIONS

Machine in working configuration refers to situations in which the machine is operational and running.

In this case the general conditions of the machine must be as follows:

- The machine is switched on at the main ON/OFF circuit breaker.
- The machine is stabilized within the allowed limits.
- Operator present in the machine control station.
- In the machine working area, there is an operator who mans the machine and the ground controls.
- There must be no other operators in the machine working area.
- The work zone must be delimited and marked.

### 2.5.5. MACHINE RETRACTED

For machine in safe conditions, we mean that condition in which the part of the machine is configured in a way to reach the minimum clearance both in height and width and the booms are resting

In this case the general conditions of the machine must be as follows:

- All extensions completely retracted.
- Both booms are closed, centred and resting on the boom supports.
- With command board active, the "machine in safe" condition status is indicated by the switchon of a green led in the luminous column.



#### Note

The machine in safe condition" status enables the stabilization and/or movement manoeuvres.

### 2.5.6. MACHINE STABILISED

Stabilized machine refers to that condition, which provides for.

- The support and the push to the ground of all the stabilizers.
- The authorisation given by the correct insertion of the locking pins of the articulation of the stabilisers.
- The crane levelling on the axes **X - Y**, within the limits provided and shown in the technical specifications.



#### Note

The status of "stabilised machine", detected by the control system, authorises the handling of the superstructure of the machine.

### 2.5.7. MACHINE PARKED IN A MINIMUM SPACE CONFIGURATION

Machine recovered in minimum size implies the condition whereby the aerial part of the machine is configured in such a way as to reach the minimum size in height and width, the booms are rested and the machine is without the basket.

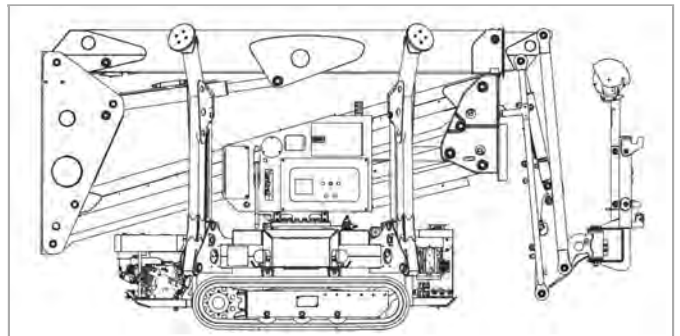

In this case the general conditions of the machine must be as follows:

- Stabilisers fully lifted.
- Narrow tracks.
- Upper boom completely closed.
- Boom extension fully returned.
- scissor boom arm recovered.
- Centred column.
- The jib fully closed.
- With command board active, the "machine in safe" condition status is indicated by the switchon of a green led in the luminous column.



#### Note

The machine in safe condition" status enables the stabilization and/or movement manoeuvres.

## 3. TECHNICAL SPECIFICATIONS

### 3.1. TECHNICAL GENERAL SPECIFICATIONS

Description	Units of measurement	Measurements
Maximum allowable people in basket	-	2
Fatigue usage class (Classification according to Standard EN 13001-3-1: 2018)	-	S0
Ambient operating temperature – Min÷max	°C	-20÷+40
Maximum working slope for chassis	°	1
Maximum Horizontal force allowed	daN	40
Maximum wind speed allowed during work	m/s - ft/s	12,5 - 41

TECHNICAL SPECIFICATIONS		VERSION		
		D - B - E - ED - EB		
Maximum working height.	ft - m	47.6 - 14,5		
Maximum surface height.	ft - m	41 - 12,5		
Maximum lateral range.	ft - m	21.3 - 6,5		
Maximum basket load.	lb - kg	507 - 230		
Aluminium basket dimensions.	inch m	55.1x27.6 1,4x0,7		
Basket rotation angle.	°	70-70		
Turret rotation angle.	°	180 + 180		
Length of machine closed with basket.	ft - m	15.3 - 4,67		
Length of machine closed without basket.	ft - m	13.1 - 3,99		
Minimum width machine closed in the basket.	inch m	31.10 0,79		
Minimum height closed machine.	inch m	78.3 1,99		
Overall stabilisation dimensions		D - B	E	ED - EB
Wide position.	ft - m	9.2x9.2 - 2,8x2,8		

Maximum gradient which can be exceeded.	(%) degree- s.	31 17			
Maximum lateral gradient. Continuous tracks closed. Continuous tracks open.	% - ° % - °	27 - 15 31 - 17			
maximum shifting speed.	mph km/h	1.37 2,2	0,81 1,3	1.37 2,2	
<b>Tank capacity</b>		<b>D - B - E - ED - EB</b>			
Hydraulic oil tank.	gal - l	4.39 - 20			
Fuel tank (Diesel fuel).	gal - l	1.09 - 5			
Fuel tank (Gasoline).	gal - l	1.61 - 6,1			
<b>Noise level</b>		D	B	E	ED - EB
Measured sound power Lwa.	dB(A)	103	100	-	100
Guaranteed sound power Lwa.	dB(A)	105	102	-	102
Sound pressure.	dB(A)	<80	<80	-	<80
Total vibrations allowed.	m/s <sup>2</sup> - in/s <sup>2</sup>	<0,5 - <19.7			
<b>Electrical system</b>		<b>D - B - E - ED - EB</b>			
Emergency electric pump 12 V	kW	1,6			
Electric pump 220 V	kW	2,2			
Electric pump 110 V	kW	1,5			
Starter battery.	Ah	55			
Electric circuit.	V	12			

<b>Weights</b>		B	D	E	EB	ED
Weight in work order *	lb	4392	4392	4698	4694	4694
	kg	1992	1992	2131	2129	2129
Load on the ground machine on tracks.	psi	2.95	2.95	3.15	3.15	3.15
	kN/m <sup>2</sup>	20,3	20,3	21,8	21,7	21,7
Live loads, stabilized vehicle.	psi	0.37	0.37	0.39	0.39	0.39
	kN/m <sup>2</sup>	2,54	2,54	2,72	2,72	2,72
Maximum force on a stabilizer.	lbf	2810	2810	2810	2810	2810
	kN	12,5	12,5	12,5	12,5	12,5

\* May vary depending on configuration.

<b>Engines</b>		D - B	E	ED - EB
Net installed power Diesel engine Hatz 1B30	kW@rpm	5/3200	-	5/3200
Net installed power Petrol engine Honda iGX390	kW@rpm	8,2/3600	-	8,2/3600
Electric motor 110V ac	Cv/kW	2/1,5	-	-
Electric motor 220V ac	Cv/kW	3/2,2	-	-
Electric motor 24V dc	Cv/kW	-	5,4/4,0	5,4/4,0
24V dc Lithium-ion traction battery capacity	Ah	-	300	200
Lithium-ion battery recharger	Ah	-	100/50	100/50
Operating altitude limit for internal combustion engine.	m - ft (a.s.l)	610 - 2001 <sup>(1)</sup>		

<sup>(1)</sup> For operation at higher altitudes, contact the Manufacturer.

**3.2. OVERALL DIMENSIONS**

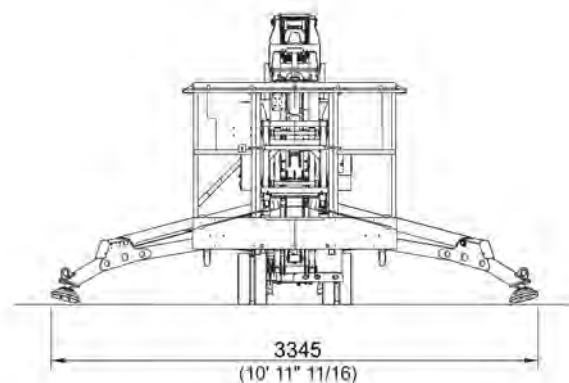
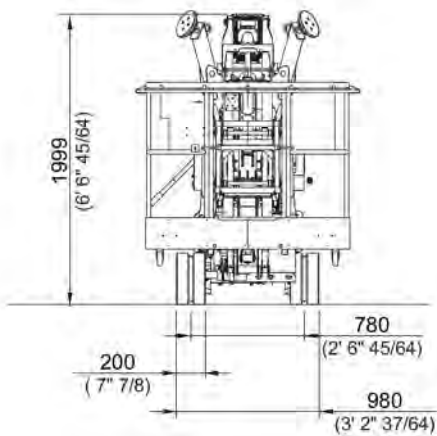
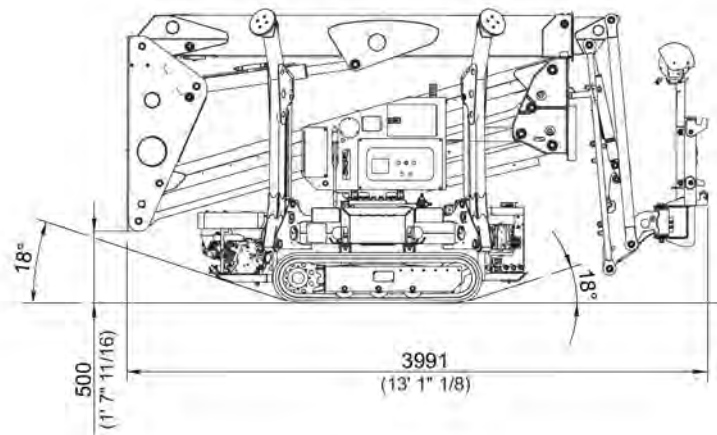
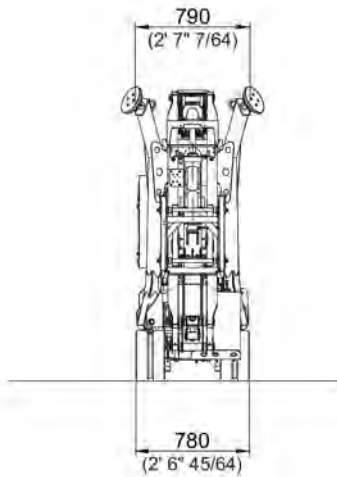
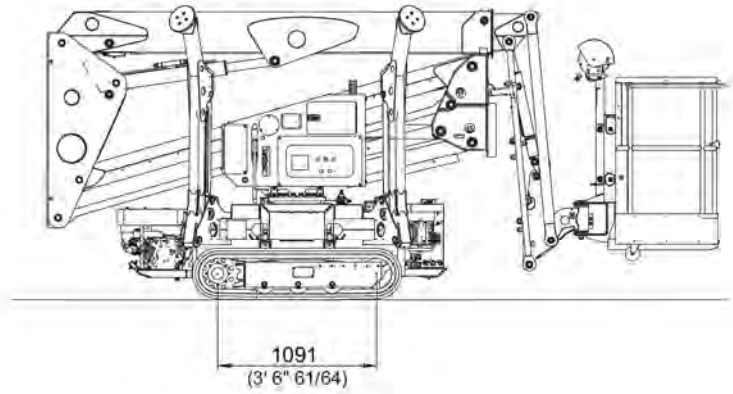
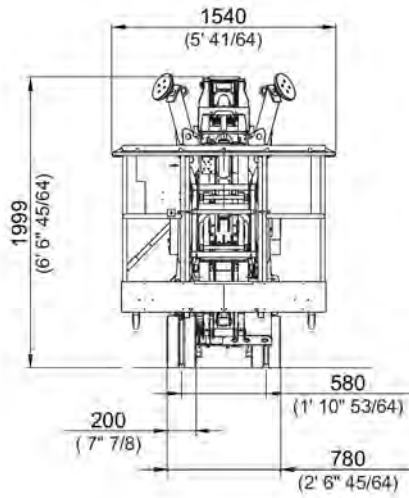

### 3.3. OUTRIGGING DIMENSIONS

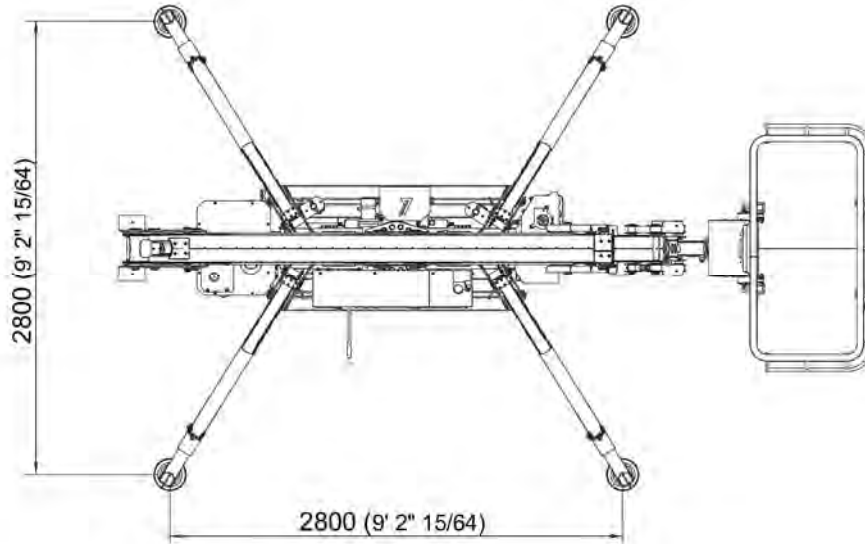

**3.4. POSITIONING DIMENSIONS**

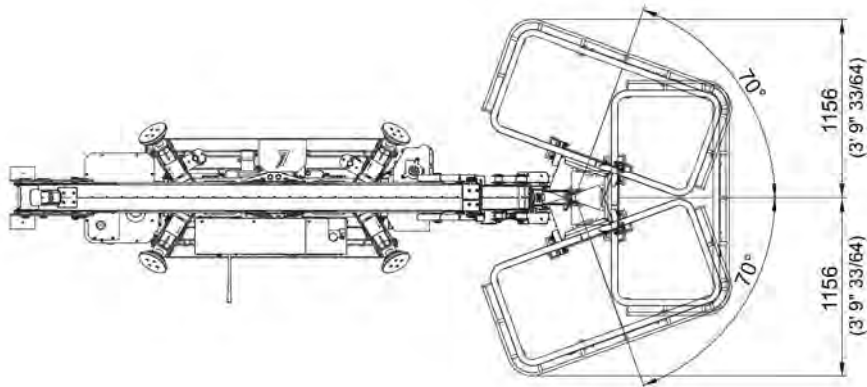
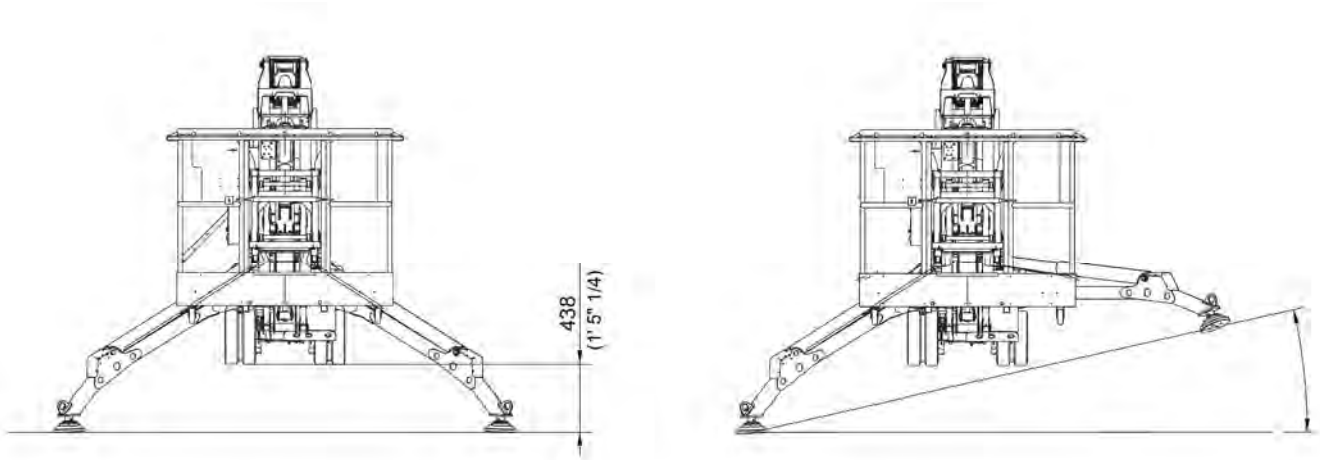

**3.5. WORKFLOW DIAGRAM  
(LOAD 230 kg)**

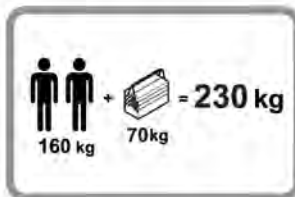
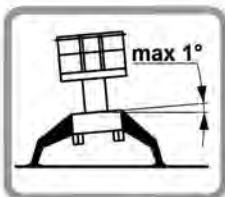
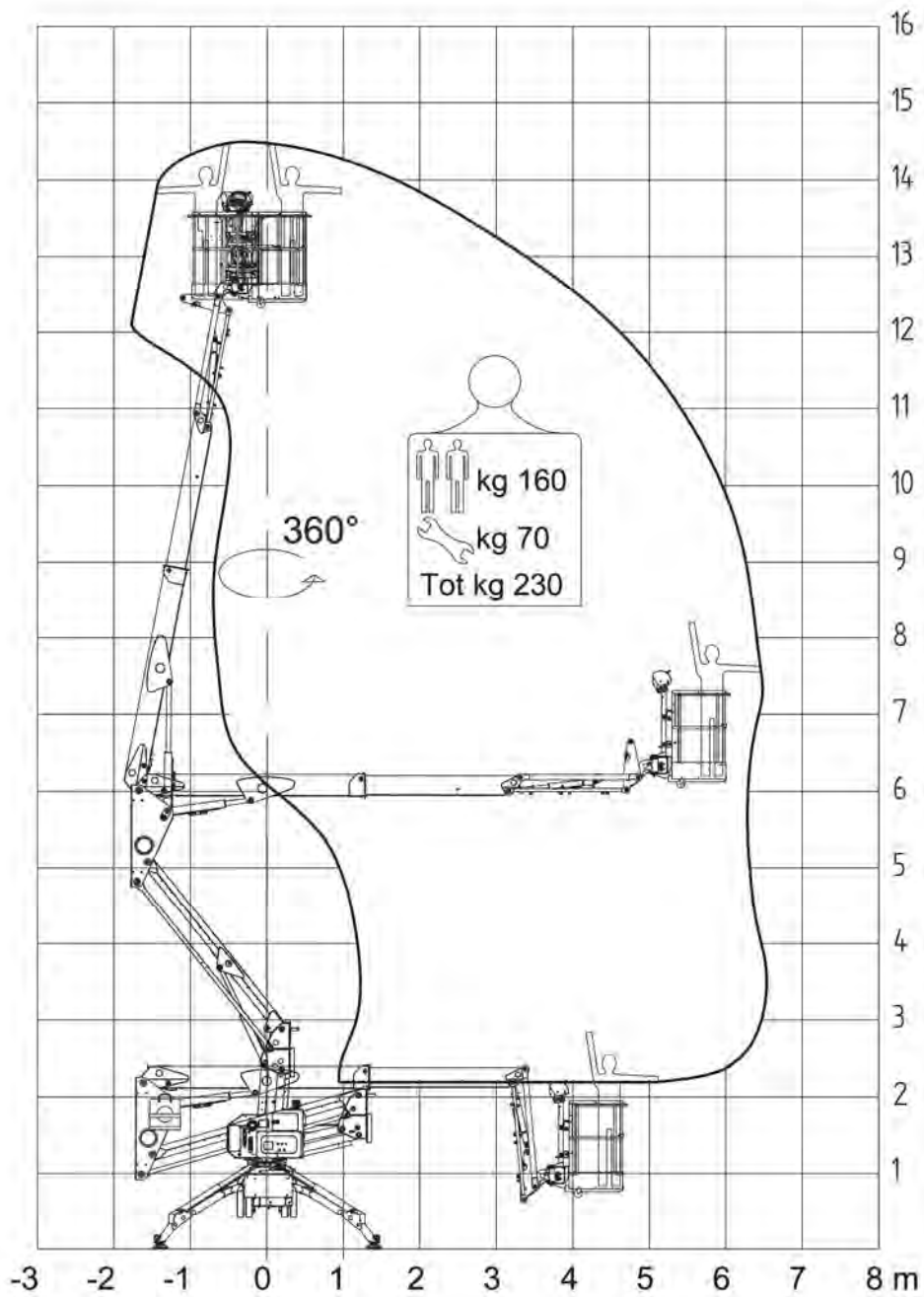

**3.6. WORKFLOW DIAGRAM  
(LOAD 507 lb)**

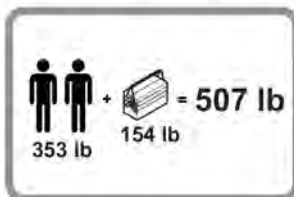
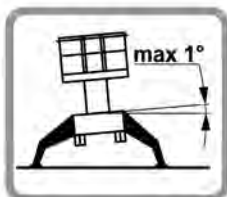
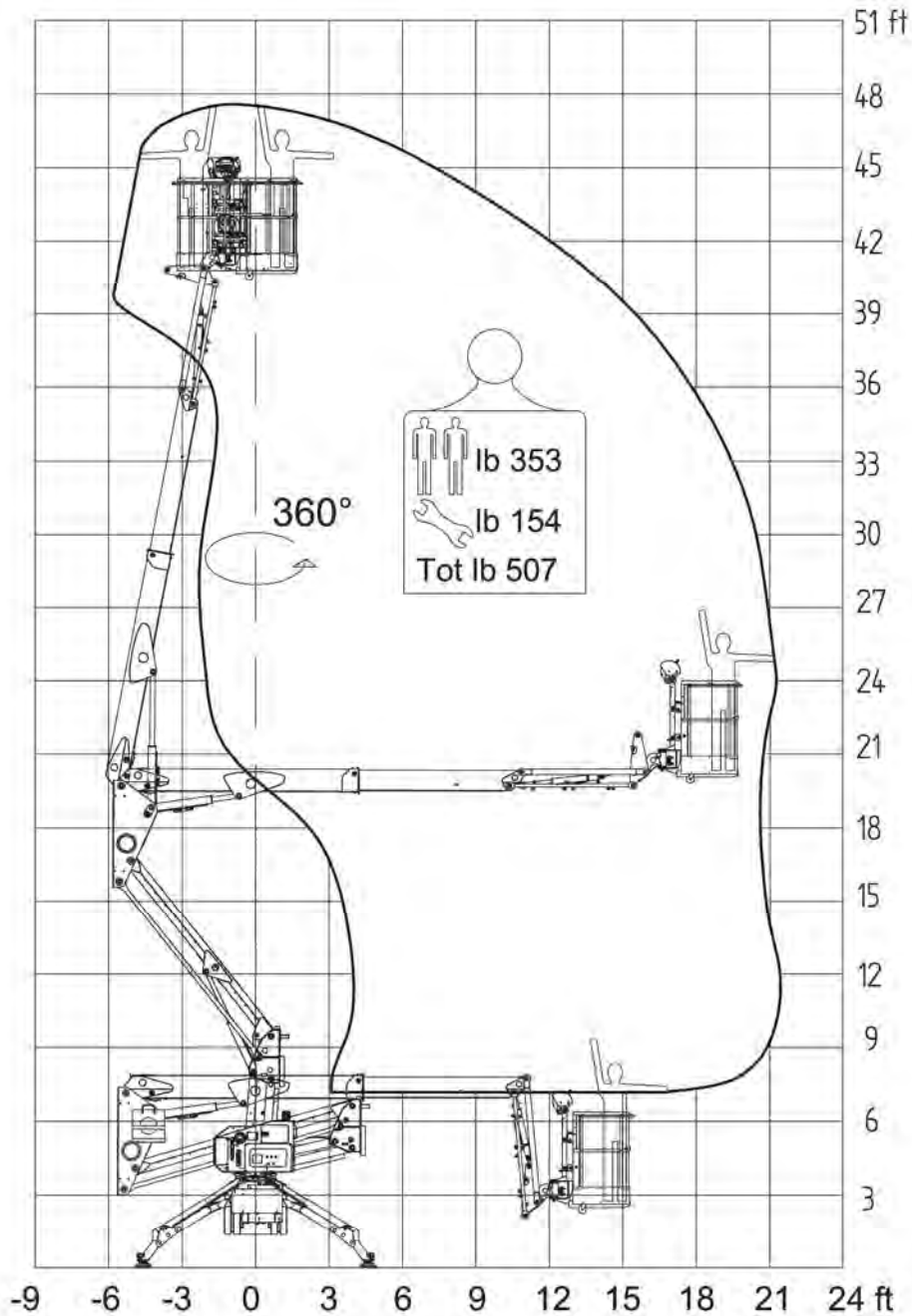

## 4. SAFETY

### 4.1. GENERAL SAFETY RULES

Most of the accidents that occur at work are due to negligence in the maintenance or operation of the machine.

It is therefore necessary to read this manual so as to be able to operate in the greatest possible safety and always maintain the machine in a state of efficiency.

- Maintain a distance of more than **5 m** from live electrical cables.
- The machine is not electrically insulated and does not protect from contact with or proximity to power lines.
- Keep the safety distance from power lines and high voltage equipment, established by the laws in force in the country where the machine is used.
- Calculate the distance, bearing in mind the platform's field of action, possible oscillation, low power lines and wind factor.
- Do not use the machine as ground wire when welding.
- Do not use the machine in the event of storms or in the presence of lightning.
- Keep a distance of at least **2 m** from high differences in height (ditches, steep terrains, etc...).
- Ensure that there is enough fuel to avoid a forced stop of the machine.
- Wear a safety helmet and safety belt connected to the special hook in the basket.
- The handles and running boards must be kept clean of mud, oil, grease and other substances.
- It is forbidden to load the basket at a height.
- It is forbidden to use the basket to lift loads.
- Overloading, lifting sideways, sudden shocks, brusque and sudden movements of the basket are forbidden.
- The machine can only be used on ground that is solid enough for all four stabilizers to be set on the ground.
- Check that every stabiliser and the relative supporting material makes complete contact with the ground before starting the works and thereafter, implement regular inspections.
- Before each work session check the passive and active safety measures.
- The machine may be used only and exclusively when in good working order.
- The basket operator must be assisted by a suitably trained person on the ground.
- It is forbidden to get on or off the machine when it is being controlled from the ground.
- It is forbidden to remove, except for the purposes of maintenance, the protective panels and/or casings.
- It is forbidden to stabilise the machine unless all the pins that secure the stabilisers have been inserted.
- When moving the machine over uneven or inclined ground, ALWAYS keep the stabilisers OPEN and NEAR to the ground.  
This arrangement of the machine is ALWAYS advisable unless it impedes movement through narrow passages.
- Never open the motor compartment without previously cutting off the current from the control panel on the ground.
- In the area under the working range of the basket there must be no obstacles or causes of danger to the descent of the basket.
- Make sure there is no-one and prevent anybody being present in the area below the basket working area.
- It is forbidden to leave the machine in a state other than the rest position and without first removing the keys from the control panel.
- It is forbidden to use the machine when there is lightning or when weather conditions are likely to produce lightning.
- Before boarding the basket ensure that it is horizontal and if necessary adjust it by means of the special controls.

- It is forbidden to use the machine where the wind speed is greater than **12**.
- Never move over a slope or on ground that could give way.
- In conditions of poor visibility it is forbidden to use the machine as it is not provided with its own illumination.
- It is forbidden to drive the machine on roads open to traffic.  
The machine is not homologated for such use.
- An operator must not accept operative responsibility unless adequate training has already been given by competent authorized personnel.
- Before operation check there are no overhead electric lines, no other machines such as bridge cranes, machines operating on road and rail, and building equipment in the working area.
- Before starting work the operator and the person in charge must take suitable precautions in order to avoid known dangers.
- Do not operate the machine unless maintenance has been done in compliance with the specifications and the expiry dates indicated by the manufacturer.
- Ensure that daily inspections and checks on correct working are carried out before using the machine.
- Check that there is enough space above, beside and under the basket when performing lifting, descent, boom rotation or when using the telescopic function.
- Make sure that the operators of other aerial or ground machines are aware of the presence of the aerial basket.  
Switch off the current to aerial cranes.  
If necessary place obstacles on the ground.
- Do not push or pull the machine or other objects using the telescopic mechanism of the boom.
- Do not rest parts on the basket railing without the approval of the manufacturer.
- Never use the boom other than for moving personnel, their tools and equipment to the work position.
- Never exceed the rated capacities of the basket.  
Consult the load diagrams shown in this manual.  
Place loads evenly on the floor of the basket.
- Never work with a machine in poor working condition.
- If there should be a break down, stop the machine, place a CLEARLY VISIBLE sign and advise the personnel in charge.
- Sudden or erratic movements must not be done on the basket.
- The operator is prohibited to move between the basket and a structure outside the machine, machine stability could be jeopardised.  
The personnel and the equipment must enter and exit the cage only with the extensions retracted or machine in safe position.
- Never use ladders or steps, or similar objects on the basket or under the machine in order to obtain additional reach for any reason.
- When moving about or working on the basket both feet must be firmly placed on the bottom of the basket.
- Never walk on the boom to reach the basket or to leave it.
- If the boom or the basket is trapped with one or more stabilizers raised from the ground, all the personnel must be removed from the basket before setting about freeing the machine.  
If necessary use cranes, forklift trucks or other equipment to remove personnel and stabilize the machine.
- The operator is responsible for preventing personnel on the ground from using the machine controls and warning them not to work, walk or stop under the boom or the basket.  
Cordon off the machine at ground level if necessary.
- When the machine is to be relocated, check that there are no people, holes, gutters, sudden changes in ground level, obstructions, debris and covers that may hide holes or other hazards.
- Do not move the machine on gradients higher than those indicated in the technical specifications.
- Never move the machine with the arm raised.  
The machine can only move with machine in safe conditions.
- To prevent the machine from toppling over do not drive over soft or uneven surfaces.

- Make sure that the conditions of the land are suitable to support the maximum load of the stabilizers. if necessary, use suitable under-plates to increase the support surface and, consequently decrease the specific pressure on the ground.
- Do not drive the machine near to ditches, loading bays or other changes in ground level.
- When relocating the machine check that there are no obstructions around or above the machine while it is in motion.
- When moving the machine the stopping distance must be known.
- Where visibility is obstructed call for an assistant and use the acoustic warning signal.
- When the machine is moving, keep all non operative personnel at least **2 m** away.
- The machine is not compliant with the ATEX directives; accordingly, it cannot be operated in environments, subject to explosion and/or fire risks.
- It is forbidden to use the machine in potentially explosive environments, where flammable and combustible substances in the form of gases, vapours, liquids and powders can be found.

**Caution**

The machine has an operating keyboard with a display;  
On this display all the control components that are broken are listed.  
Therefore, before starting work with the machine always check the display for alarm signals.

## 4.2. GENERAL PREPARATION

This section provides the personnel responsible for making the machine ready and for its entry in operation with the information necessary and lists the checks that are to be done before operating the machine. It is important that the information given in this section is read and understood before using the machine. Ensure that all the necessary inspections have been done with positive outcomes before using the machine. These procedures have the purpose of lengthening the working life of the machine and guaranteeing its safety.

**Caution**

Since the manufacturer is unable to exercise any direct control over the inspections on the spot and maintenance work, these activities fall under the exclusive responsibility of the owner and the operator.

## 4.3. MAKING READY FOR USE

Before using a new machine it is necessary to inspect it carefully for any evidence of damage sustained during shipment and then to give it routine inspections as indicated in the section “Inspections to be done routinely and on receiving the machine”.

During start up and initial operation, the machine must be checked carefully for hydraulic fluid leaks.

The activities for making the machine ready for use come under the responsibility of personnel in charge.

The activities for making the machine ready for use come under the responsibility of personnel in charge.

Make ready requires common sense (for example the telescopic boom should extend and retract without encountering obstacles and the brakes should work correctly) combined with a series of visual inspections.

The compulsory requirements are listed in the section “daily visual inspections”.

It is necessary to verify that the directions listed in the sections “Inspections on receipt”, “Routine Inspections” and “Daily working order check” have been followed.

## 4.4. INSPECTIONS TO BE DONE ROUTINELY AND ON RECEIPT

### Note

An annual inspection of the machine must be carried out no later than **13** months after the previous annual inspection or according to the regulations in force for the type of machine.

The inspection must be carried out by qualified personnel who have experience with our products.

The frequency, the extension of periodic examinations and tests depend on the regulations in the machine's Country of use.

The following list systematically outlines the inspection procedure aimed at detecting parts that are defective, damaged or incorrectly installed. The list indicates the components to be inspected and the conditions to be examined.

Regular inspections should be done after every **3** months or **150** hours of use, whichever expiry comes first or at closer intervals where environmental conditions or heavy duty and frequency of use require.

This list is also applicable for machines placed in storage or those exposed to severe or changeable climates and must be carefully followed.

These inspections must also be done after maintenance work has been carried out.

### 4.4.1. FRAME

- Check that the belts are not worn or loose, that all parts and bolts are in position and tight.
- Check that the solenoid valves and hydraulic tubes are not damaged or leaking and that they are secured in position.
- Check the electrical voltage and make sure there are no traces of corrosion on the electrical connections.
- Check the drive gears, electrical or hydraulic motors, brakes and any hydraulic tubes present for damage or leaks.
- Check that the ground controls do not have loose or missing parts and that all parts are locked in position.
- Check the voltage in the electrical connections, make sure that there are no traces of corrosion or exposed wires.  
Ensure that all the switches work properly.
- Check the oil level in the drive gears.  
(If necessary contact the service personnel for assistance).

### Note

The drive gears must be half full of lubricant oil.

- Check the batteries (if present), ensuring that the bleed valves are not loose or missing, that the electrical connections are secure and are not corroded and that the electrolyte level is correct.
- Check that the tank and hydraulic pipes are not damaged or leaking and that the refill plug is locked in position.
- Check all electrical cables for damaged or missing parts.
- Check accessories, making certain that they are not damaged, that no parts are loose or missing, and that they are locked in position.
- Check all the access doors for damage and that the locks and hinges work correctly and are secured in position.
- Check that the fuel lines are not damaged or leaking and that they are secured in position.

#### 4.4.2. TURRET

- Check the turret for damage, loose or missing parts and that it is locked in position.  
Check that the rotation gears and its brake do not show signs of damage, loose or missing parts, that the hydraulic pipes and the component housings do not show signs of leaks;  
Check that the slewing gear is not worn.
- Check the slewing ring for damage, wear, lubricant and for loose or missing bolts.
- Check that the solenoid valves and hydraulic tubes are not damaged or leaking and that they are secured in position.  
Check the electrical voltage and make sure there are no traces of corrosion on the electrical connections.
- Check the voltage in the electrical connections, make sure that there are no traces of corrosion or exposed wires.  
Ensure that all the switches work properly.
- Check that the securing bolts of all the pins are tightened in position and do not show signs of wear.
- Check that all the joints of moving parts are lubricated.
- Check that the hydraulic directional control valve and its tubes are not leaking or damaged.

#### 4.4.3. BOOMS

- Check that the booms, cylinders and pins are locked in position and do not have damaged or missing parts.
- Check that the securing bolts of all the pins are tightened in position and do not show signs of wear.
- Check that the hydraulic pipes and electrical cables are secured in position and do not have damaged or missing parts.
- Check all the bushings for signs of wear or damage.
- Check that all the joints of moving parts are lubricated.
- Check that the sliding blocks have no visible signs of damage, missing parts and that they are locked in position.
- Check that the chains (if any) of the sliding parts have no signs of damage or missing parts and that their tension is correct.

#### 4.4.4. BASKET



#### **Danger**

It is strictly prohibited to install any cage other than the original.

It is important to know that:

- The machine is tested and certified with the cage installed at the time of delivery.
- The electronic control system is set and calibrated based on the type of cage installed at the time of delivery.
- Check that the basket and the control panel are in position and that there are no damaged, loose or missing parts.
- Check that the switches, control levers and electrical connections are not live and that there are no traces of corrosion.  
Check that all the cables are not defective or damaged.  
Ensure that the switches work properly.

- Check that the basket rotation system is secured in place, well-lubricated, operates correctly and is not damaged.  
Check that the hydraulic pipes are secured in position and that they are not damaged or leaking.

**Note**

Check that all the signs DANGER, WARNING, INSTRUCTION applied all over the machine are in position and legible.

**4.4.5. STABILISER**

- Check that the stabilizer are locked into position, that they do not show signs of damage and that the hydraulic pipes do not leak.
- Check that the cylinders for the stabilizer feet are tightened in position, do not show evident signs of wear and that the hydraulic piping shows no leakage.
- Check that the securing bolts of all the pins are tightened in position and do not show signs of wear.
- Check that all the joints of moving parts are lubricated.
- Check all the bushings for signs of wear or damage.
- Check that the hydraulic pipes and electrical cables are secured in position and do not have damaged or missing parts.
- Check the tightening of the sensors and stabilizer feet.

**4.4.6. JIB**

- Check that the booms, cylinders and pins are locked in position and do not have damaged or missing parts.
- Check all the bushings for signs of wear or damage.
- Check that the securing bolts of all the pins are tightened in position and do not show signs of wear.
- Check that all the joints of moving parts are lubricated.
- Check that the hydraulic pipes and electrical cables are secured in position and do not have damaged or missing parts.

**4.5. BOLT AND SCREW TIGHTENING**

The tightening torque table (see the pages specified) consists of standard torque values, based on the diameter and the class (hardness) of the screws; this also establishes the torque values with and without lubricants according to the practice recommended by the factory.

This table is provided for the purpose of helping the user or the operator if the need should arise for immediate adjustment during an inspection or operation so that the maintenance service personnel are informed.

Using the tightening torque table in combination with the index of the points to be tightened shown in the chapter entitled "Maintenance" will improve the safety and performance of the machine.

**4.6. DAILY VISUAL INSPECTION**

Inspection on workdays before starting up the machine comes under the responsibility of the operator and the user.

Operators and users are advised to inspect the machine before use, even if the machine has already been used by another user/operator.

This daily visual inspection is the best inspection system.

These checks must also be made after maintenance has been done to the machine.

In addition to the daily visual inspection, make sure that the following operations are included as a part of the daily inspection procedure:

- General cleaning.  
Check that all the weight-bearing surfaces are free of spills of oil, fuel, hydraulic oil, mud and foreign bodies.

- Check the general cleanliness.
- Plates.  
Keep all the plates showing information and control labels clean and visible. To keep them visible it is advisable to cover them when spraying paint or sand blasting.
- Operating and maintenance manual.  
Ensure that a copy of this manual is kept in the special container.
- Machine logbook.  
Ensure that notes are kept, or even better a logbook for the machine; ensure that it is kept up to date and that nothing is left in doubt, as this could reduce the safety of the machine.
- Begin each working day with the batteries charged and/or a full tank of fuel.

**Caution**

To avoid injury, do not operate the machine unless all breakdowns have been repaired.

The use of a defective machine constitutes a violation of the safety rules.

To avoid injuries ensure that the electrical current is switched off during the daily visual inspection.

**Note**

Check visually and manually that the safety micro-switches are in position and that they are working correctly.

- Check that the brakes work correctly when the machine is moving on a slope with gradient not exceeding the specification in the technical data, and stop the machine.

**Note**

After changing the oil on new and recently overhauled machines and all those which have had the hydraulic oil changed, operate all the movements for at least two full cycles and check the oil level in the tank again.

- Ensure that all the parts requiring lubrication are given maintenance.  
Refer to the specific pages for the methods to be adopted.

## 4.7. DAILY WORKING CHECKS

Once the visual inspection has been completed, it is necessary to do a working check of all the systems in an area free of ground and aerial obstructions.

First use the ground controls and check all the functions operated by these controls.

Then use the controls on the basket to check all the functions operated from this position.

**Caution**

Check that the stabilizer feet positioning sensors work properly.

See section **6.1.2.** (Stabiliser feet ground pressure sensors).

**Caution**

To avoid serious injuries, do not operate the machine if any one of the controls that operate it does not return to its off or neutral position when released.

**Caution**

To avoid collisions and injuries if the machine does not stop when a command is released, remove your foot from the foot-switch (if present) or use the emergency button to stop the machine.

**Note**

NEVER move the machine while the boom is raised from the resting position (The operation of the tracks and stabilizers must be disabled).

- Lower and raise the booms of the machine.  
Check that the operation is correct and without obstacles.

 **Note**

Carry out the checks on the ground controls first and then the basket controls.

- Raise, extend, retract and lower the booms.  
Check that the operation is normal and without obstructions.
- Extend the telescopic boom so that it moves from the retracted position to the extended position and vice versa a number of times with different lengths of extension.  
Check that the telescopic mechanism works correctly and without obstruction.
- Rotate the turret to the left and then the right by a minimum of **45°**.  
Check that the rotation occurs without obstruction.
- Check that the basket automatic levelling system works correctly during raising and lowering of the boom.
- ground controls.  
Rotate the general key switch to the OFF position.  
No command must be operating.  
Neither the commands of the basket need to run.
- Check the efficiency of the motors installed on the machine (connection, enabling, battery status, etc.), which will be used for routine and emergency maneuvers.

#### 4.8. GENERAL INSPECTION

begin the visual inspection from the number on the list shown below.

Continue to check the condition of each part indicated in the list of daily visual inspection checks.

 **Caution**

To avoid injury, do not operate the machine unless all breakdowns have been repaired

The use of a defective machine constitutes a violation of the safety rules.

To avoid injuries ensure that the electrical current is switched off during the daily visual inspection.

 **Note**

Do not underestimate the importance of inspecting the base of the frame.

Checking this area often reveals conditions that can cause serious damage to the machine.

- Basket unit - no part is loose or missing; no visible damage; the fixing and/or articulation pins are tightened in position.
- Command board on the cage - the switches are positioned correctly; no part loosened or missing; no visible damage; labels and plates present, integral and legible; command signs legible.
- Balancing cylinders - no visible damage; the articulation pins are correctly tightened in position; the flexible hoses have no visible damage or traces of leaks.
- Lifting and extension booms/cylinders - no visible damage; the articulation pins are correctly tightened in position; the flexible hoses have no visible damage or traces of leaks.
- Limitation micro switches - micro switches operating, no visible damage.
- Brake, gears, drive engine - no visible damage; no evidence of leaks.
- Track unit - notched wheels correctly tightened into position; no loosened or missing screw or nut; no visible damage; track in order.
- Hydraulic oil filter - filter correctly tightened into position; no visible damage; no evidence of leaks.
- Casings - casings correctly fixed into position; no loosened or missing part.
- Command electric valves - no loosened or missing part; no evidence of leaks; no electric cable or flexible hose without support; no damaged or broken electric cable.
- Fuel supply - refill plug tightened in position; no visible damage on the tank and no evidence of leaks; correct level.
- Hydraulic oil tank - correct oil level (check the level when the oil is cold, the components are at a standstill and the machine is in the rest position). cap tightened in position.

- Batteries - correct electrolyte level; electric cables tightened without visible trace of damage or corrosion.
- Engine air filter - correctly tightened in position, no loosened or missing part; no visible damage; clean filtering element.
- Engine oil - level of the oil on the correct reference of the dip stick; refill plug tightened in position.
- Hydraulic pump - no loosened or missing part; no evidence of leaks.
- Muffler and exhaust system - correctly tightened in position; no evidence of leak.
- Turret slewing ring - no loosened or missing screw or nut; no visible damage; appropriate lubrication; no evidence of loosening between the bearing and the structure.
- Motor and gear rotation - no loosened or missing screw or nut; no visible damage; appropriate lubrication.
- Cylinders of the cage rotation device (if present) - no visible damage; the flexible hoses not damaged and without leaks.

#### 4.8.1. MAINTENANCE OF THE BATTERIES

To avoid injury caused by explosion, do not smoke near the batteries or bring a naked flame or a source of sparking close during maintenance work.



#### Caution

Always wear protective goggles when doing maintenance on the batteries.

- The batteries do not need maintenance except for the occasional cleaning of the terminals as described below.
- Remove the cables from each terminal of the battery one at a time beginning with the negative terminal.  
Clean the cables with a neutral solution (for example: sodium bicarbonate and water or ammonia) and a metal wire brush.  
Replace the electrical cables or the screws in the terminals if necessary.
- Clean the terminals of the battery with a metal wire brush then reconnect the cables to the terminals.  
Apply mineral grease or vaseline to the surfaces that are not in contact.
- When all the cables and terminals have been cleaned make sure that the cables are secured correctly and not squashed.  
Close the battery housing cover panel.

#### 4.8.2. ELECTRIC PUMP MAINTENANCE

Follow the instructions given in the manufacturer's manual.

### 4.9. QUALIFICATION OF OPERATING PERSONNEL

In order to be qualified for its use, the operator must possess all the requirements of law and of the regulations, in force in the country of use of the machine.

The personnel using or operating the machine must be competent and meet the following requirements:

- **Physical**  
Good eyesight, hearing, co-ordination and the ability to safely carry out all the necessary facilities required for use of the machine.
- **Mental**  
Ability to understand and apply the established safety standards, precautions and rules.  
Must be attentive, use good judgment for personal safety and the safety of others.  
They must think about how to carry out the work correctly and responsibly.
- **Emotional**  
Personnel must be calm and able to withstand stress and to use good judgment in regard to their physical and mental conditions.

## 4.10. PERSONNEL TRAINING



### Caution

**In some countries, in order to use the machine, some laws and regulations in force require for compulsory training and instruction courses**

The lifting platform is a machine intended for use by personnel. as a result it is essential that its operation and maintenance are entrusted only to authorized personnel who have demonstrated that they understand how to use and maintain the machine.

It is important that all the personnel assigned to the unit and responsible for the operation and maintenance of this machine follow a thorough training programme and complete a period of probation in order to become familiar with the operational features of the machine before using it.

Persons under the influence of alcohol or drugs and persons suffering from epileptic fits, dizziness or loss of motor nerve control must not be allowed to use the machine.

## 4.11. OPERATOR TRAINING

Operator training is based on the following.

- 1 Use and limitations of the controls in the basket, those on the ground and the emergency controls.
- 2 Knowledge and comprehension of this manual and the control signs, instructions and warnings affixed to the machine.
- 3 Knowledge of all the work safety rules imposed by the employer and the laws in force, including training in regard to the recognition and prevention of potential dangers present in the place of work, with special attention to the specific job to be carried out.
- 4 Correct use of all mandatory personnel safety equipment, in particular the use of a safety helmet and other fall-prevention equipment, such as a fall protection harness.
- 5 Sufficient knowledge of the mechanical working of the machine to be able to recognize actual or potential breakdowns.
- 6 The best ways to operate the machine in the proximity of suspended obstructions, other moving equipment and where there are obstructions, depressions, holes, sudden dips, etc. in the surface supporting the machine.
- 7 The safest ways to avoid danger from bare electrical conductors.
- 8 Any other requirement specific to a given application of the machine.

## 4.12. TRAINING SUPERVISION

The training must take place under the supervision of a qualified operator or supervisor, in an open area without obstacles until the personnel under training have developed the ability to safely operate the lifting platform in congested areas.

## 4.13. OPERATOR'S RESPONSIBILITIES

The operator must be informed that he has the responsibility and the authority to stop the machine in the case of a breakdown or other conditions of reduced safety associated either with the machine or the work place and to request instructions from the supervisor or the distributor of the product before proceeding further.



### Note

At the time of delivery of the first unit and, successively, at the request of the user or his personnel, the manufacturer or the distributor will provide qualified personnel to assist in the training of the operators.

#### 4.14. WORKING CLOTHES

Always ensure you are wearing suitable work apparel before approaching the machine and/or starting work with the machine.

When working with the machine the following precautions must be observed:

- Wear close fitting apparel without loose appendages that may be caught up in moving and rotating parts of the machine.
- Wear clothes with appropriate fastening systems (buttons, zips, velcro, etc.) and always fasten them.
- Sleeves must be close-fitting, belts properly fastened, bibs and braces correctly secured.
- Do not wear scarves, ties, etc.
- Do not wear sweaters, aprons and similar garments hanging on the shoulders or tied around the waist.
- Do not wear necklaces, chains, bracelets, rings or watches.
- Do not work with loose long hair, it must be pulled back.

#### 4.15. WORKING AND TRANSIT AREA

Keep the work stations and transit areas clear of obstructions and clutter at all times.



##### Caution

Do not run in the vicinity of the machine.

Always proceed at a walking pace, paying attention to the possible presence of obstacles.

Ensure that there are no other persons in the immediate proximity of the machine during machine operation and maintenance.

##### 4.15.1. OPERATING POSITIONS

The operating positions of the machine are as follows:

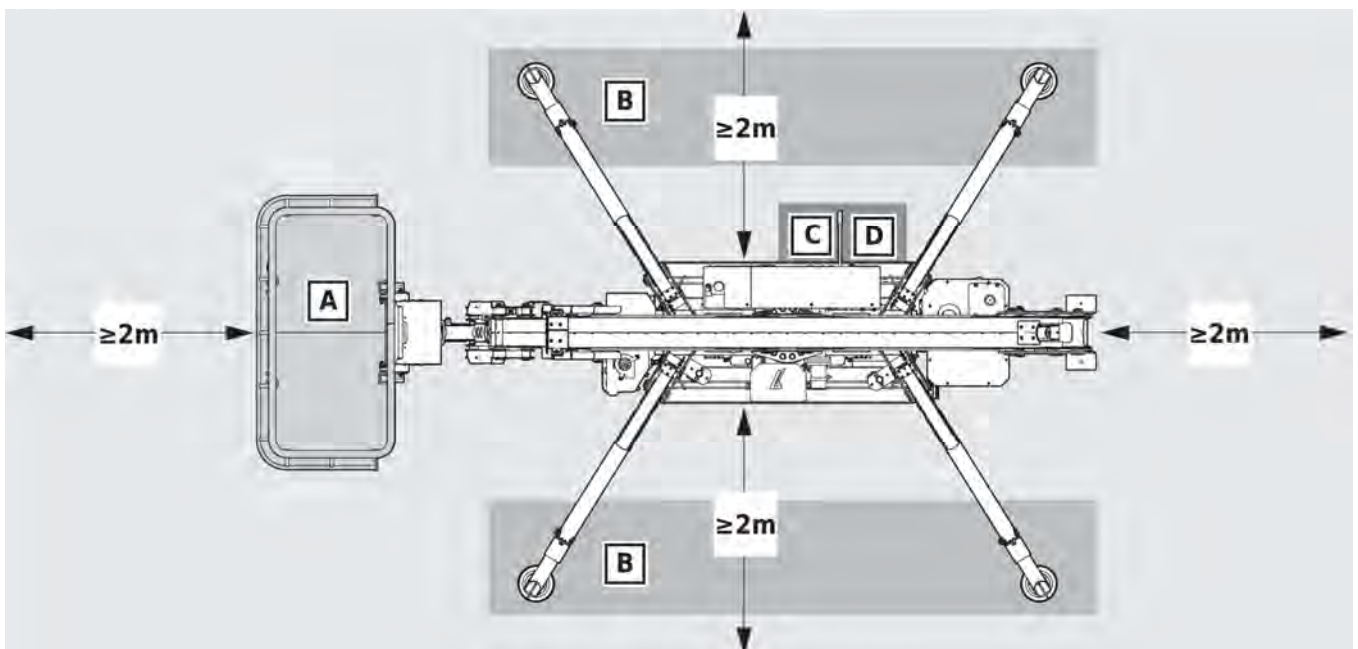

- A)** On the basket for **1+2** operators.



##### Note

The position in the basket can also be used for shifting.  
[→ § 9.12. Shifting]

- B)** On the side of the machine but NOT under the boom for the second operator on the ground.  
This position must be used:
  - to control work operations.
  - during movement.
  - during stabilization.
- C)** Control post dedicated to activities tied to the ground control panel and machine diagnostics.
- D)** Position dedicated to the selection of distributors for emergency manual interventions, for emergency manual pump actions and for emergency manual manoeuvres of the superstructure and ground structure.  
For remote control emergency manoeuvres, it is possible to occupy the areas **(B)**.

## 4.16. CONTROLS

Keep all the machine controls in perfect working order at all times.

Ensure the controls identification plates are always perfectly legible.

Do not place beverages or other liquid containers on the control console or on other electrical equipment: electric shock hazard in the event of spillage of liquids on electrical parts.

### 4.16.1. EMERGENCY STOP

“emergency stop” controls are present on the machine and must be activated in the event of an immediate presumable danger.

Therefore be aware of the position of the various “emergency stop” controls in order to use them promptly when necessary.



#### Caution

Before restarting the machine or parts of the machine after an emergency stop, ensure that the causes of the emergency stop have been remedied and check carefully to ensure that there are no persons or obstacles in potentially dangerous areas.

## 4.17. RESIDUAL RISKS AND RULES OF CONDUCT

During machine operation, a number of residual risks may arise; it is therefore necessary to adopt the precautions listed below.

Type of risk	Conduct to adopt
<p><b>Risk of electrocution</b></p> <p>The machine is constructed in compliance with statutory safety regulations concerning electrical systems.</p> <p>There is an electric shock hazard in the case of damage to cables and electrical equipment, with the associated risk of serious or fatal injury.</p>	<p>Always check that electrical cabinets are in perfect condition and properly closed, and that power cables, cable glands, and electrical equipment are in perfect condition.</p> <p>Inform the company’s maintenance service immediately in the event of damage.</p>
<p><b>Fire hazard</b></p> <p>Electrical equipment may be the source of fire outbreaks.</p>	<p>Always ensure the electrical equipment is in perfect condition and repair any damage.</p> <p>If a fire starts disconnect power by setting the all-pole main disconnect switch to OFF and then use extinguishers that are compatible with electrical fires.</p>

<b>Risk of shearing</b> The risk of shearing exists during the boom movement and turret rotation phase.	Keep clear of the machine during the movement phase.
<b>Danger of being hit /crushed</b> The risk of knocks and crushing exists during the movement and stabilisation phase.	Keep safe distance.
<b>Risk of falling tools</b> The risk of tools or material falling from the basket exists.	Do not stand or pass under the basket.
<b>Risk of falling from a height</b> The risk of falling from a height exists during the operator's ascent to and descent from the basket.	Hold on firmly to the designated supports.

#### 4.18. PERSONAL PROTECTIVE EQUIPMENT (PPE)

When carrying out the normal working activity and during maintenance operations it must be guaranteed that the operators are provided with and use the following personal protection devices.



- **Cut-resistant and piercing-resistant gloves**

Contact with sharp parts.

- **Oil-proof gloves**

Contact with lubricating oil and grease and hydraulic fluid.



- **Safety footwear with reinforced toecap and nonslip sole**

Slippery floors.

Falling of heavy components.



- **Fall prevention device from a high position.**

The operator in the basket must compulsorily wear and hook in the prearranged rings the fall prevention harness, as provided by the regulations, which rules safety on workplaces in high positions.



#### Caution

The personal protection devices must be carefully stored and replaced when damaged.

#### 4.19. METHOD USED TO ACCESS HAZARDOUS AREAS

To prevent access to hazardous parts composed of moving parts in general, guards are present on various machine parts (made of sheet metal, metal mesh, plastic etc.) and are fixed with screws and/or nuts etc....



To avoid the risk of serious injury due to the presence of moving parts adhere strictly to the following rules of conduct.

The guards must always be present and correctly secured during machine operation.

The guards must only be removed by authorised personnel using suitable tools.

The guards must only be removed when the machine is at a standstill and cannot be restarted by third parties.

Before performing maintenance work disconnect the machine from the energy sources and affix a sign stating "Work in progress. Do not use".

Before restarting the machine, reposition the guards and secure them as envisaged by the manufacturer.

The threaded fasteners must be torqued in such a way as to prevent their removal using only the hands or makeshift tools.

#### 4.20. SAFETY REGULATIONS FOR MACHINE MAINTENANCE

The maintenance operations may only be carried out by authorised personnel suitably trained and skilled and expressly authorised by the company using the machine.

Maintenance work on the machine must be performed in observance of all the safety indications given in the present publication.

Before performing maintenance work disconnect the machine from the energy sources and affix a sign stating "Work in progress. Do not use".

The instructions below must also be observed.

#### 4.20.1. CONSULTATION OF TECHNICAL DOCUMENTS

Before performing maintenance work on the machine, read the technical documentation supplied by the manufacturer and the suppliers of individual commercial parts of the machine.

In particular consult:

- Instructions.
- The diagrams of the electrical, hydraulic, pneumatic systems, etc.

The manufacturer's technical service is at your complete disposal for any information concerning maintenance work to be carried out on the parts supplied.



#### **Caution**

In the case of operating faults do not attempt to solve any anomalous situations that may occur using makeshift means.

#### 4.21. REPLACEMENT PARTS

The use of non-authentic spare parts may cause machine malfunctions, which in turn may lead to hazardous situations for the operator and any individuals working near the machine.



#### **Caution**

Always use exclusively genuine original replacement parts supplied by the manufacturer.

## 5. CONTROLS

### 5.1. GROUND CONTROL PANEL

#### SA40 Key switch and enabling of base/basket controls

- Switch to OFF turns off the machine.
- Switch turned to the centre switches the machine on and enables the ground controls. The ground working position has priority over the basket position.
- Switch turned to the right switches the machine on and enables the basket controls.

#### SB53 Spark plug pre-heating button/light (With diesel engine only)

The led flashes and switches off after **6 - 7 s**, with glow plugs heated.  
Press to pre-heat the diesel engine glow plugs.

#### SB52 Button/indication light of internal combustion or electric motor boot and shutdown

#### SB40A Emergency button

With the button pressed all movement is immediately stopped and the electrical power to all the controls is cut off.  
Reset by turning the button in the direction of the arrows.

#### SB66 Button "Emergency Rescue" for retraction in the event of an emergency

This switch can only be used in emergency situations to reactivate machine operation in the case of an active basket overload alarm, caused by the interference of external objects with the structural parts of the machine, which do not allow the execution of normal reset movements.

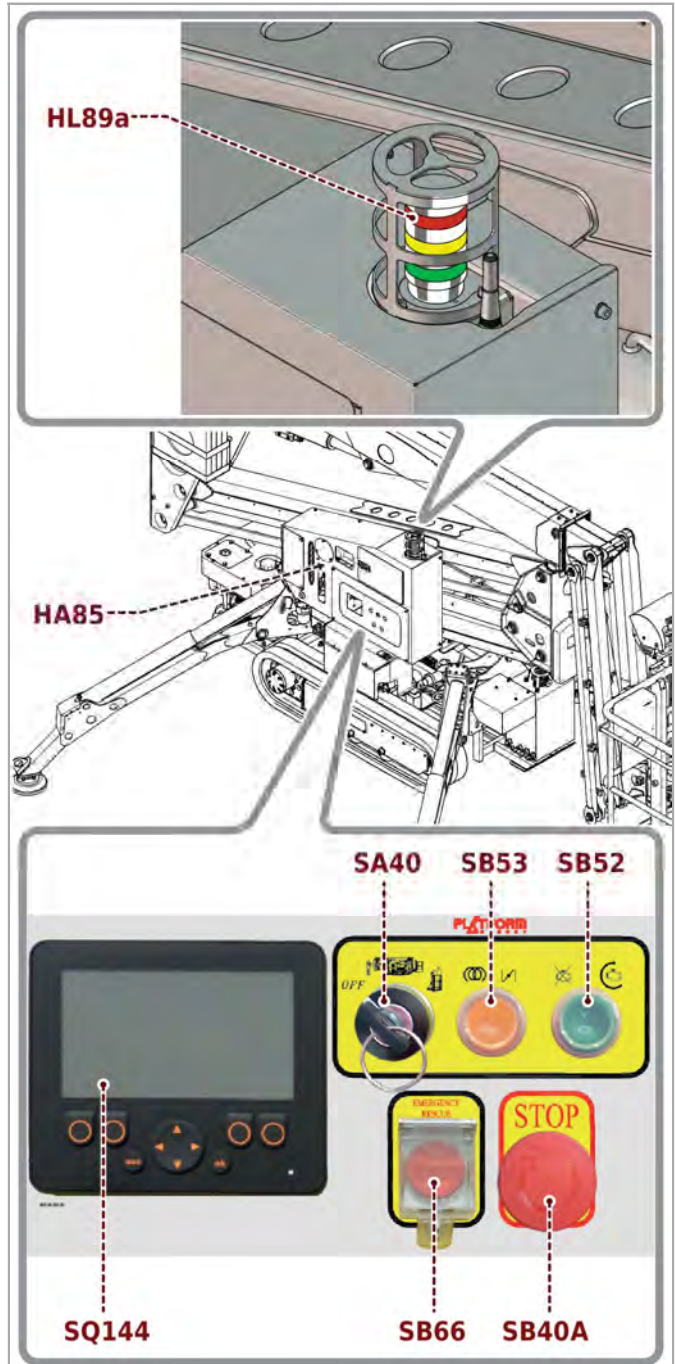

#### Caution

The button must only be used in the event of an emergency.

After pressing this button the buzzer (**HA85**) and the red lamp (**HL89a**) will remain active (see **6.1.4.** "Horn" - **6.1.5.** "Visual signal").

It is obligatory to go to an authorised workshop to perform the reset and reseal the device.

It is forbidden to use the machine that does not have the lead seal.

**SQ144 Display**

The display, during the normal operations of the platform, indicates the machine states recognised by the electronic control unit that manages the machine.



It displays the lithium battery charge (if present).

It warns about alarms or operation fault.

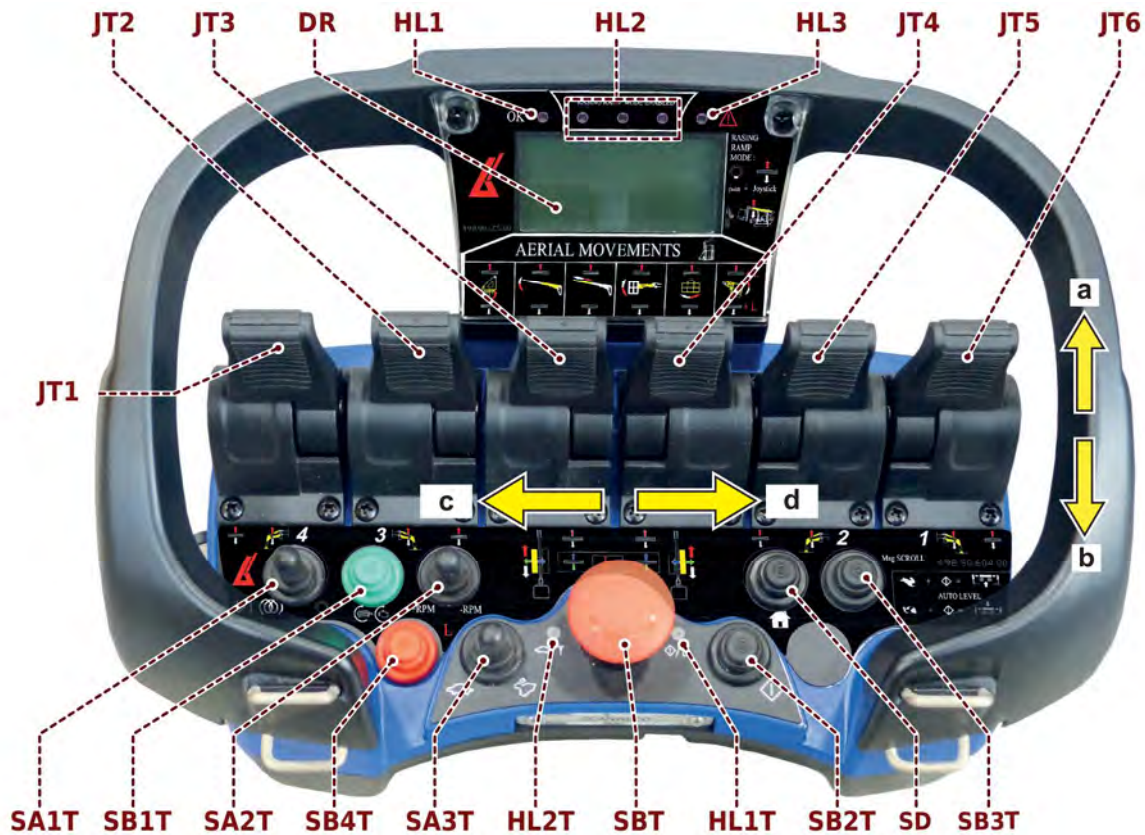
**5.2. REMOTE CONTROL**



Name	Description	Function
		<i>position a/c</i>
		<i>position b/d</i>
SA1T	<ul style="list-style-type: none"> <li>- Engine starting air.</li> <li>- Backlighting.</li> <li>- Activation of superstructure emergency controls (Position maintained).</li> </ul>	<ul style="list-style-type: none"> <li>- Activation of closure of engine starting air.</li> </ul>
		<ul style="list-style-type: none"> <li>- Display backlighting on.</li> <li>Kept in the "backlighting" position, the movements of the aerial part are enabled in an emergency.</li> </ul> <p><b>Caution</b></p> <p>The function is enabled only if the machine has been correctly stabilised.</p> <ul style="list-style-type: none"> <li>- While in the "backlight" position and simultaneously pressing the (SA3T) button in position (d) "hare", the automatic closing is enabled.</li> </ul>
SB1T	Engine start/stop button.	<ul style="list-style-type: none"> <li>- Press to start the engine.</li> <li>- Press again to stop the engine.</li> </ul>

SB2T	Black button/horn.  - Pressed it allows to activate the pushbutton panel (Until the (HL1T) led flashes slowly). - Pressed, after activation of the pushbutton panel and with all functions active, it operates as an acoustic warning device (Vehicle horn). - Pressed simultaneously to the (SA3T) in position (d), it enables the automatic stabilizing function or with (SA3T) in position (c) the automatic retraction of stabilization (Destabilization).	
SB4T	Red cage manual balancing consent button.	Press to enable use of the lever jnJT6.
	Emergency electric pump (Optional).  Enabling of track opening/closing.	Press to restart the emergency electric pump (Optional).  When held down, it enables the opening/closing of the tracks.
SB3T	Change page button (Scroll). Pressing the button allows the various functions to be shown on the display, one after the other, with the relative information present in the machine control system.   <b>Note</b> With the remote control on the ground, holding SA1T on “backlighting”, the arm can be lifted for ramp climbing.	
HL1T	Accumulator condition.	Intermittent flashing indicates that the accumulator installed on the pushbutton panel is almost exhausted. The operator has 3 minutes to replace the accumulator.   <b>Note</b> If the operator is not able to replace the accumulator in time, it is possible to convert the pushbutton panel from radio control to wire control (See 9.13. “Transforming the pushbutton panel from radio control to wire control”).
HL2T	Status led of the radio connection between transmitter/receiver.	The flashing light during the connection search phase at the receiver. The light becomes fixed when connection is made. Whenever the transmitter loses the connection (flashing light) to the receiver, press the button (SB2T) to reactivate it.
HL1	Green led.	If it is lit it means that the machine is operating and booted correctly.
HL2	Yellow Led.	The combined lighting of the LEDs signals that the ramp crossing mode is enabled.
HL3	Red LED.	The light turns on and remains lit in case of any alarm.

SA2T	Motor rpm selector.	With engine running, the system automatically regulates the minimum speed and on the basis of the movement in progress, the system selects the most suitable speed to perform the manoeuvre.	
		- Activate to have constant maximum speed allowed for all movements (motor accelerated). - Activate the selector in the opposite direction to go back to automatic speed.	- Activate to have constant minimum speed allowed for all movements (motor idling). - Activate the selector in the opposite direction to go back to automatic speed.
	The display shows the rpm mode that has been set.		
SA3T	- Shifting speed change selector. - Automatic stabilisation selector (with SB2T).	- Activate to move at slow speed. - Activate by pressing the button (SB2T) to automatically destabilize the machine. -	- Activate to move at fast speed. - Actionner en pressant le bouton (SB2T) pour stabiliser automatiquement la machine.
DR	Radio control display.		
SBT	Emergency button (Button panel off). - When pressed, it causes an immediate halt to all movements. - To reset the button, turn it, following the direction of the arrows. - When pressed, it switches of the pushbutton panel. - To enable the pushbutton panel, turn the button, following the direction of the arrows.		
SD	Available.		
JT1	Stabilizer foot 4.	Up.	Downward.
JT2	Stabilizer foot 3.	Up.	Downward.
JT3	Left track.	Move forward. Closed (*).	Backwards. Open (*).
JT4	Right track.	Move forward. Closed (*).	Backwards. Open (*).
JT5	Stabilizer foot 2.	Up.	Downward.
JT6	Stabilizer foot 1.	Up.	Downward.

(\* ) To open or close the continuous tracks, simultaneously press **SA1T**.



### Caution

To open or close the tracks, operate levers **JT3** and **JT4** simultaneously. It is not possible to open/close the single track.

**AERIAL PART CONTROLS**

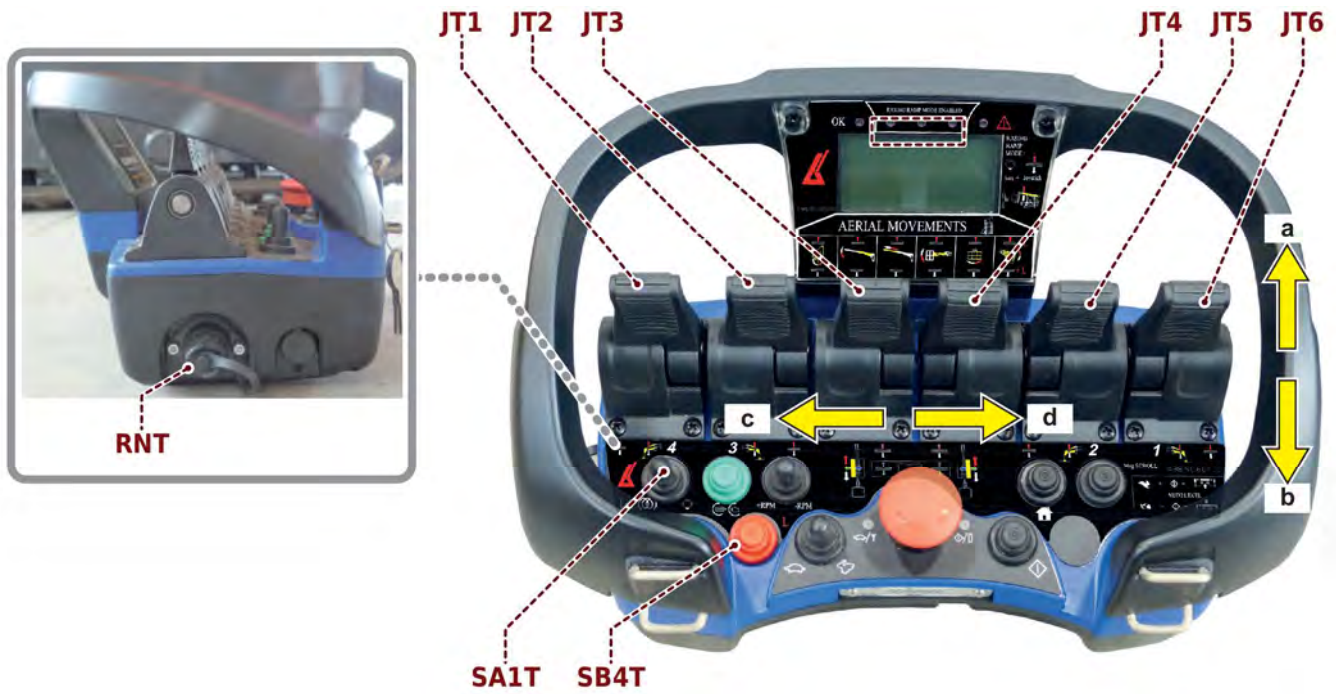

Maintain the **(SA1T)** selector activated in the "backlight position".

Name	Description	Function	
		<i>position a/c</i>	<i>position b/d</i>
JT1	Column rotation command lever.	Anti-clockwise.	Clockwise.
JT2	Pantograph boom movement lever.	Up.	Downward.
JT3	Boom movement lever.	Up.	Downward.
JT4	Extension movement lever.	Return.	Extension.
JT5	Jib movement lever.	Closing.	Opening.
JT6	Basket rotation lever.	Anti-clockwise.	Clockwise.
	Basket manual balancing lever. To enable the basket balance function, the switch SB4T must be held down simultaneously.	Backward inclination.	Forward inclination.



RNT Connection outlet for pushbutton panel operation in wire control mode.

## REMOTE CONTROL IN BASKET

### Caution

The button panel support in the basket is equipped with a sensor that detects its presence. Positioning the pushbutton panel in the support enables the operation of the movements of the aerial part.



Name	Description	Function	
		<i>position a/c</i>	<i>position b/d</i>
JT1	Column rotation command lever.	Anti-clockwise.	Clockwise.
JT2	Pantograph boom movement lever.	Up.	Downward.
JT3	Boom movement lever.	Up.	Downward.
JT3	Left track.  <b>Note</b> To operate the continuous tracks, remove the remote control from its support.	Move forward.	Backwards.
JT4	Extension movement lever.	Return.	Extension.
JT4	Right track.  <b>Note</b> To operate the continuous tracks, remove the remote control from its support.	Move forward.	Backwards.

JT5	Jib movement lever.	Closing.	Opening.
JT6	Basket rotation lever.	Anti-clockwise.	Clockwise.
	Basket manual balancing lever. To enable the basket balance function, the switch SB4T must be held down simultaneously.	Backward inclination.	Forward inclination.
RNT	Connection outlet for pushbutton panel operation in wire control mode.		

### 5.3. HYDRAULIC DISTRIBUTOR ENABLING DIVERTER - MANUAL PUMP (TO USE IN EMERGENCY CONDITIONS)

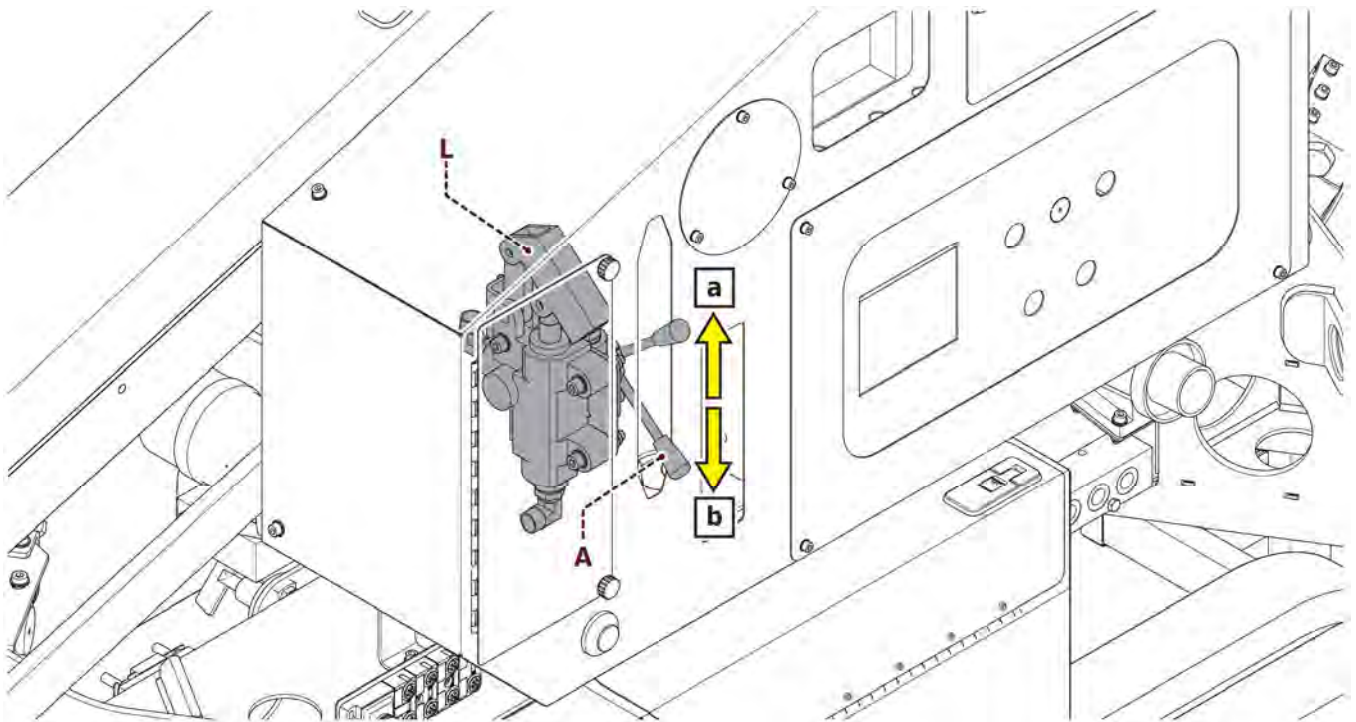

A	Hydraulic distributors enabling diverter.
position a	Enables the manual controls of the superstructure or of the left continuous track and stabilisers movement control valve.
position b	Enables the manual controls of the right continuous track and opening/closing continuous tracks movement control valve.
L	Manual emergency pump. Activate manually with lever.

**5.4. CARRIAGE MOVEMENT MANUAL COMMANDS (TO USE IN EMERGENCY CONDITIONS)**

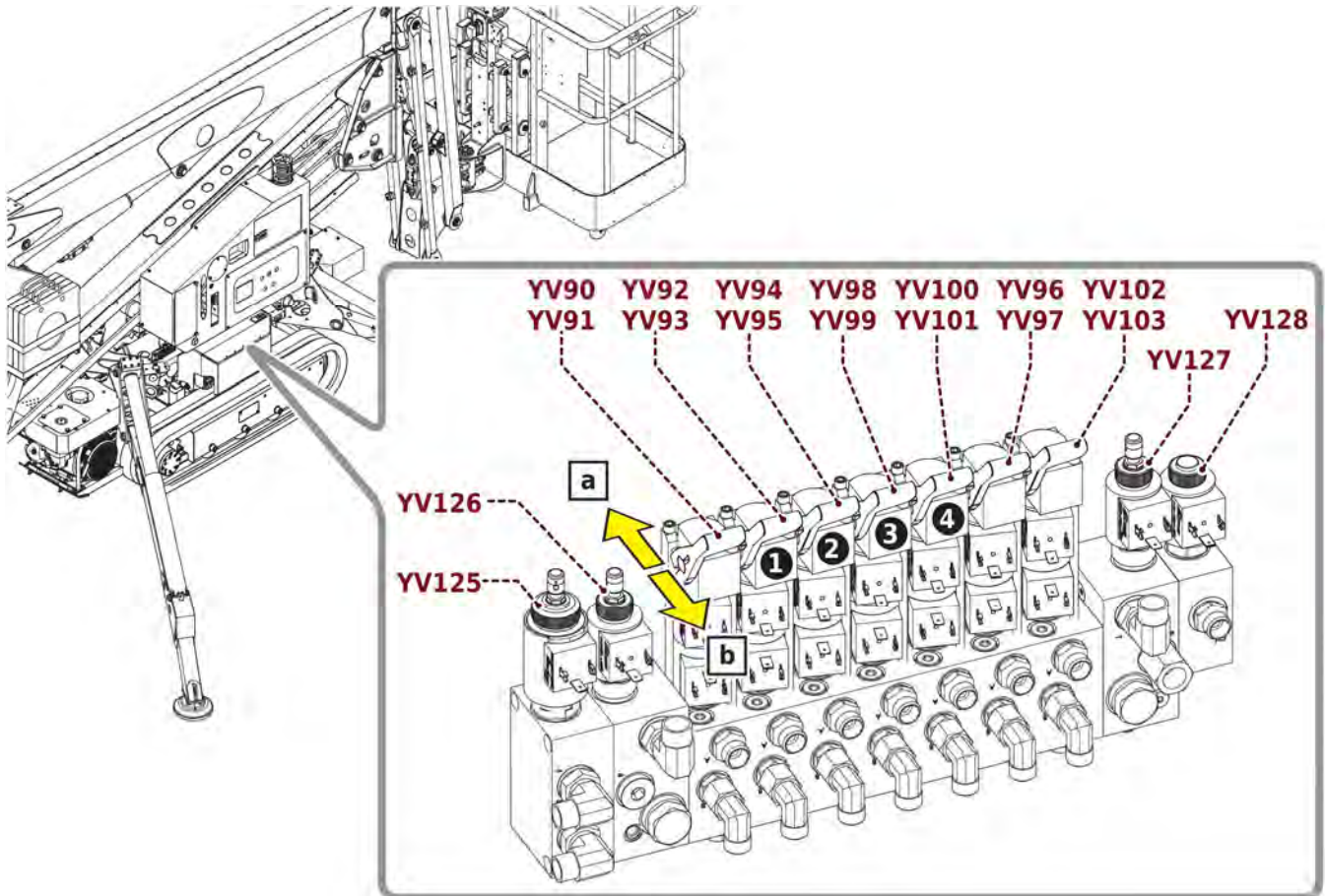

Name	Description	Function	
		position a	position b
YV90-91	Left track movement command lever.	Move forward	Backwards
YV92-93	Stabiliser foot handling lever 1	Lift	Lowering
YV94-95	Stabiliser foot handling lever 2	Lift	Lowering
YV98-99	Stabiliser foot handling lever 3	Lift	Lowering
YV100-101	Stabiliser foot handling lever 4	Lift	Lowering
YV96-97	Lever for opening/closing tracks.	Opening.	Closing.
YV102-103	Right track movement command lever	Move forward	Backwards
YV127	Bypass valve to enable the right continuous track movements.		
YV126	Bypass valve to enable the left track movements.		
YV125	Bypass valve for exchange of overhead/carriage movements.		
YV128	Continuous tracks second speed valve.		

### 5.5. AERIAL PART EMERGENCY CONTROLS

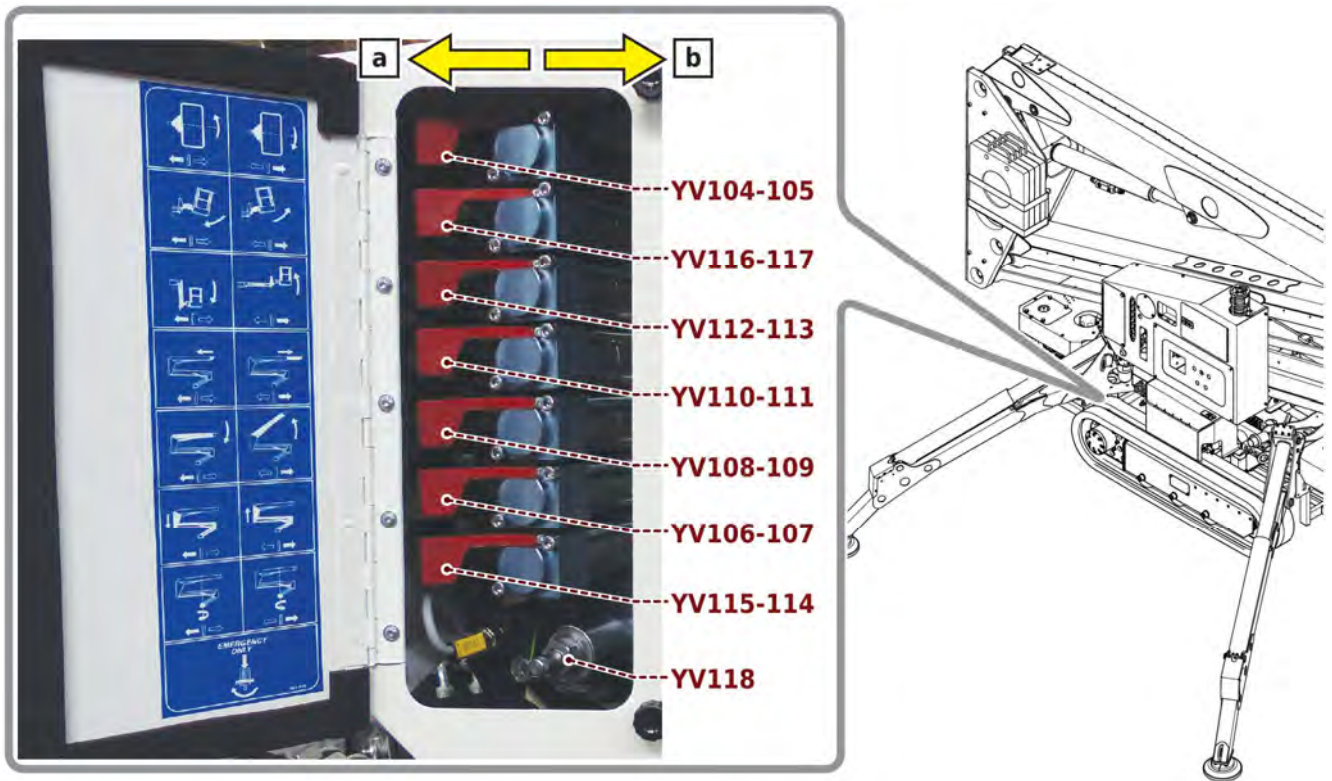

Name	Description	Function	
		position a	position b
YV114-115	Column movement lever	counterclockwise rotation	clockwise rotation
YV106-107	Lower boom movement lever	Up	Downward
YV108-109	Lower boom extension movement lever	Up	Downward
YV110-111	Boom extraction movement lever	Exit	Return
YV112-113	Jib movement lever	Up	Downward
YV116-117	Cage balancing lever	Backward inclination	Forward inclination
YV104-105	Basket rotation lever.	Clockwise.	Anti-clockwise.
YV118	By-pass valve to enable emergency movements of the superstructure.		

## 5.6. OTHER COMMANDS IN THE CAGE

### SB40 Emergency stop pushbutton.

When pressed, it causes an immediate halt to all movements.

Reset by turning the button in the direction of the arrows.

### SA26 Work engine selector switch.



#### Caution

Before starting to work with the machine, select the type of motor you want to use and then start the machine.

Check the efficiency of the motors installed on the machine (connection, enabling, battery status, etc.), which will be used for routine and emergency maneuvers.

### SB45 Operation presence pedal (dead man device) (Optional).

Press to enable the machine movement controls.



#### Caution

To carry out the various movements, always enable the man present by remote control or, if present, press the operator presence pedal (**P1**) first, then act on the command.

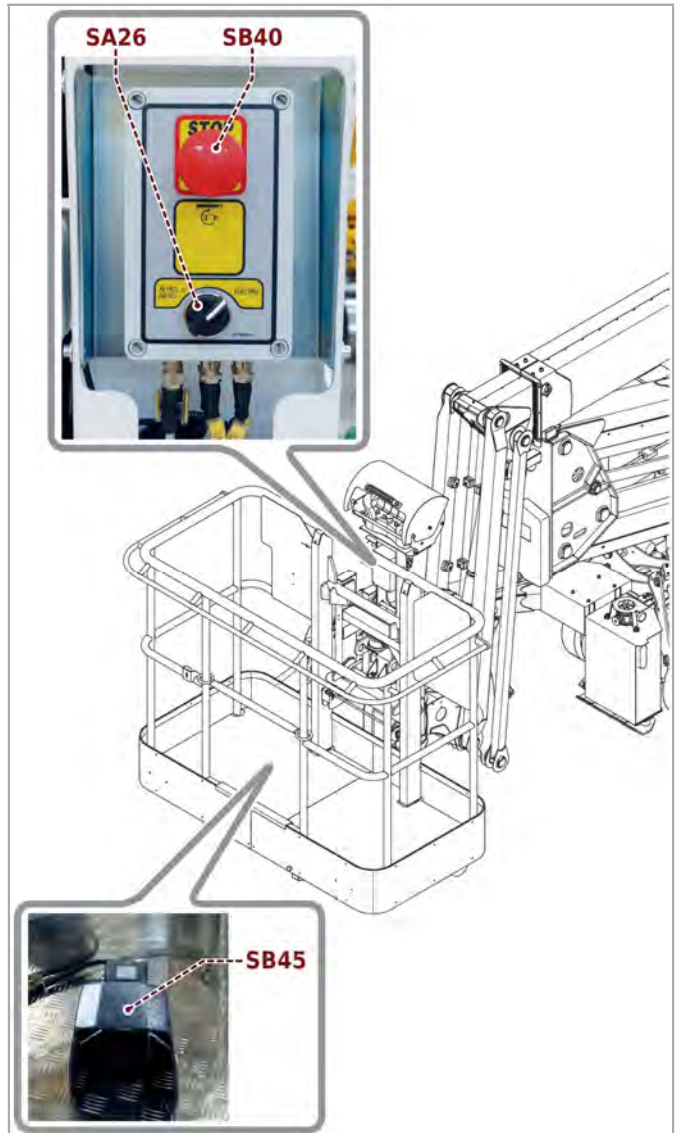

## 5.7. AIR/WATER UTILITIES IN BASKET

- A** Compressed air service utility.  
**W** Water service utility.

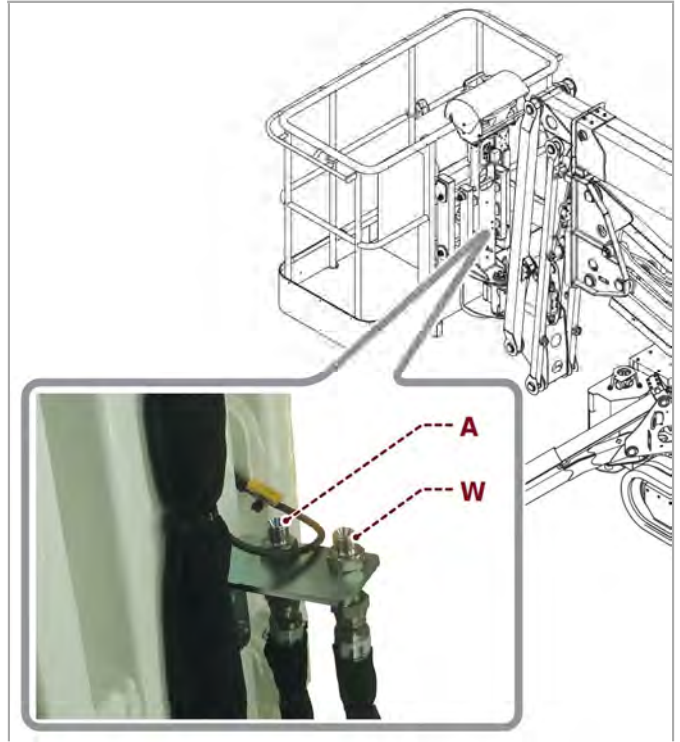

## 5.8. ELECTRIC CURRENT IN THE BASKET (OPTIONAL)

- PE** Electric current service utility outlet (230/110 V).

On request, an electric service outlet (**PE**) is installed (230/110 V).

The system is the continuation of the outlet installed on the carriage.

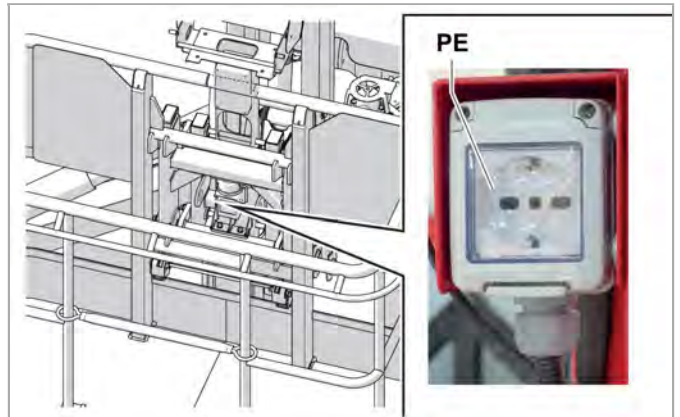

### 5.9. WORK LAMP (OPTIONAL)

On request, a work lamp (WL) is installed on the basket.

The switch is situated directly on it.

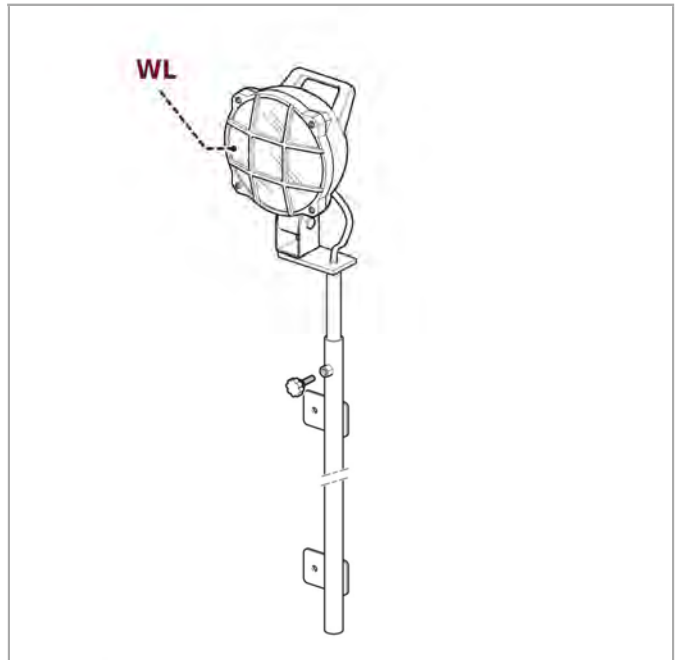

### 5.10. CONTROLS AND INSTRUMENTS ON BOARD THE MACHINE

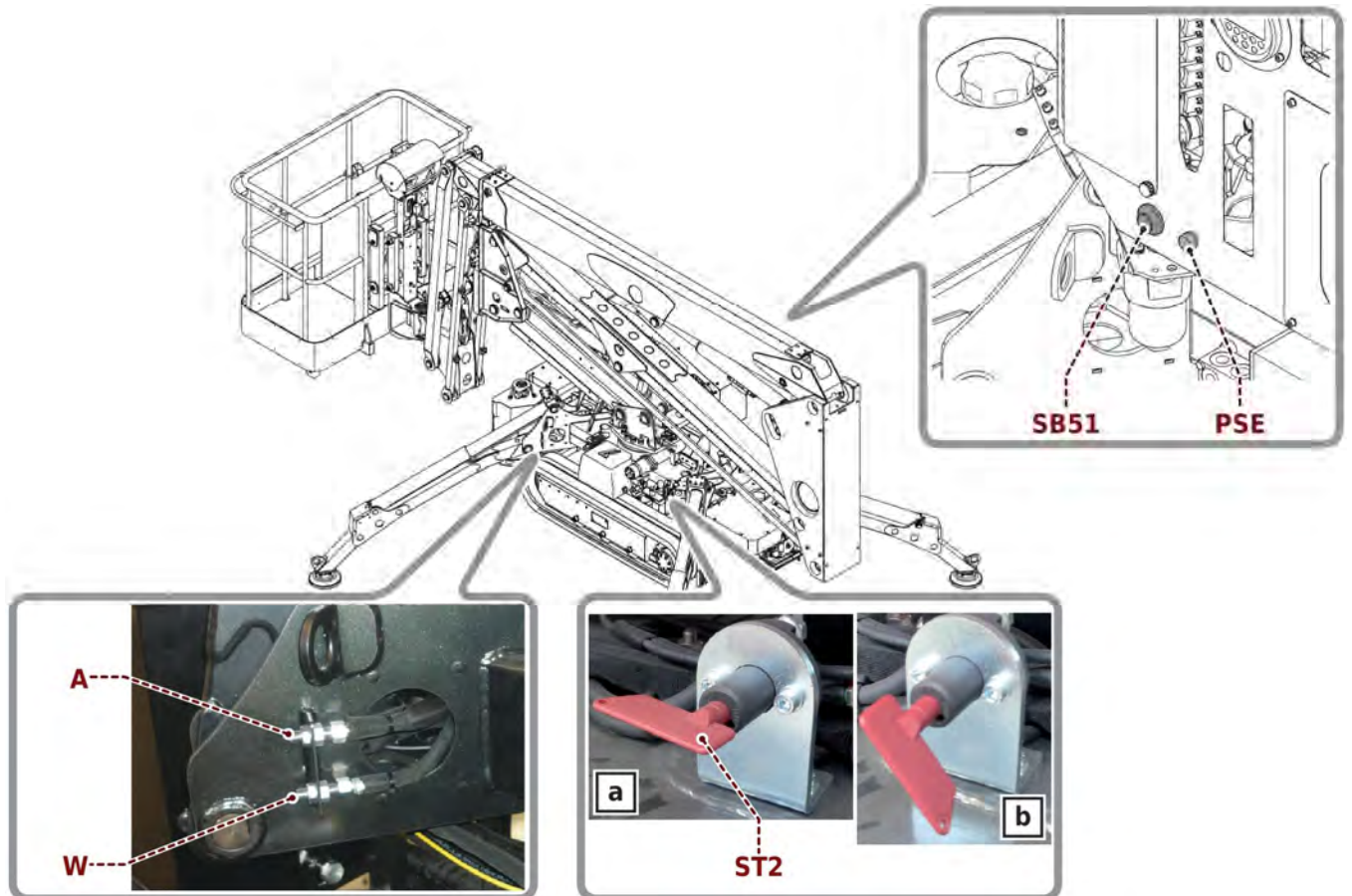

- A** Compressed air service utility connection in the cage.
- W** Water service utility connection in the cage.

- ST2** Battery switch of the endothermic motor.  
In **(a)** on position, it enables engine operation.  
In **(b)** off position, it disables engine operation.  
The key can be removed in this position.
- SB51** Button for oil return to aerial part emergency distributor.  
Pressed enables emergency movement of aerial part.  
On only with **(SA40)** selector in "controls on ground" position.
- PSE** Emergency electric pump activation button (Optional).  
When pressed, it activates the emergency electric pump.

**15.70 ED - EB - E VERSION (WITH LITHIUM BATTERIES)**

- Q2Q3** Circuit breaker to protect the electric service utility.  
**position a**  
- Enables electric service utility operation.  
- Disables the battery recharge procedure.  
**position b**  
- Enables the battery recharge procedure.  
- Disables electric service utility operation.
- PWRS** Low/high power charge selector switch.  
Depending on the electric line available, one can choose whether to charge the battery with low power (longer charging time) or high power (shorter charging time).



**Note**  
For further information, see the appendix attached to the lithium batteries.

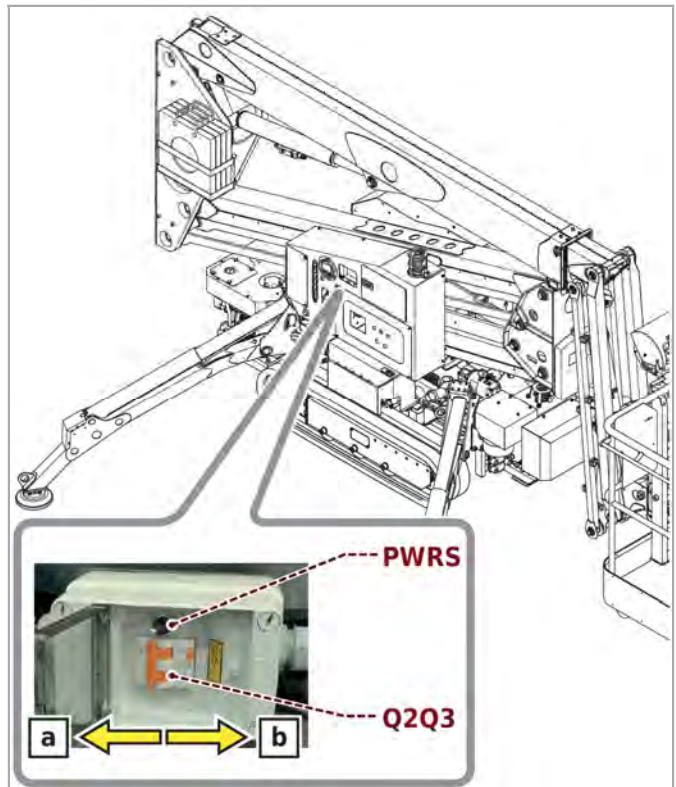

**15.70 ED - EB VERSION (WITH INTERNAL COMBUSTION ENGINE AND ELECTRIC MOTOR 230/110 V)**

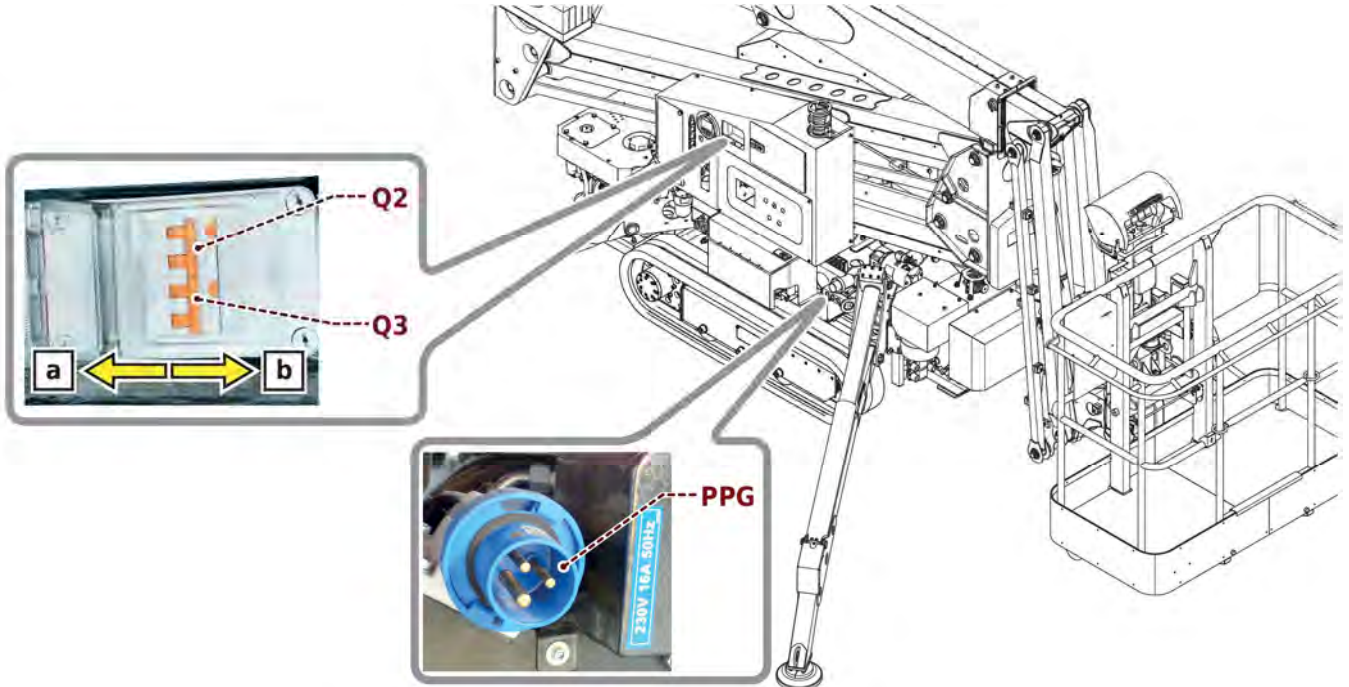

**Q2** Circuit breaker to protect the electric service utility on the basket.

**position a**

Enables electric service utility operation.

**position b**

Disables electric service utility operation.

**Q3** Circuit breaker to protect the electric circuit of the engine **230/110 V**.

**position a**

It enables the power supply of the electric engine.

**position b**

It disables the power supply of the electric engine.

**PPG** Current outlet from external electrical system.



**Caution**

During the machine movement phase, check that the cable and the connection are not damaged.

## 5.11. DISPLAY

### General Requirements.

The display, during the normal operations of the platform, indicates the machine states recognised by the electronic control unit that manages the machine.

The automatic display of messages can be replaced with the system's other consultation and diagnostic methods.

The system consultation and diagnostic method is obtained by pressing the keys **A-B-C-D-E**-**"esc"**-**"ok"** (See 5.11.1. "Description and use of keys").

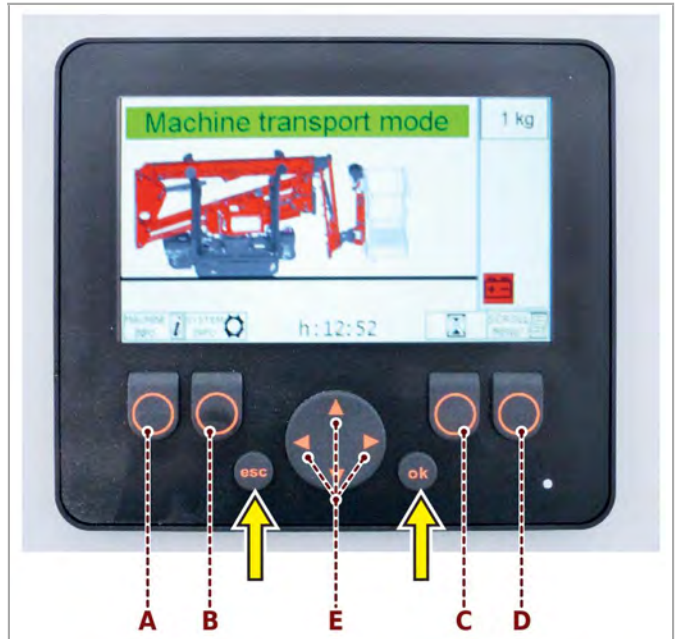

The additional functions activate when the key under the desired icon is pressed.

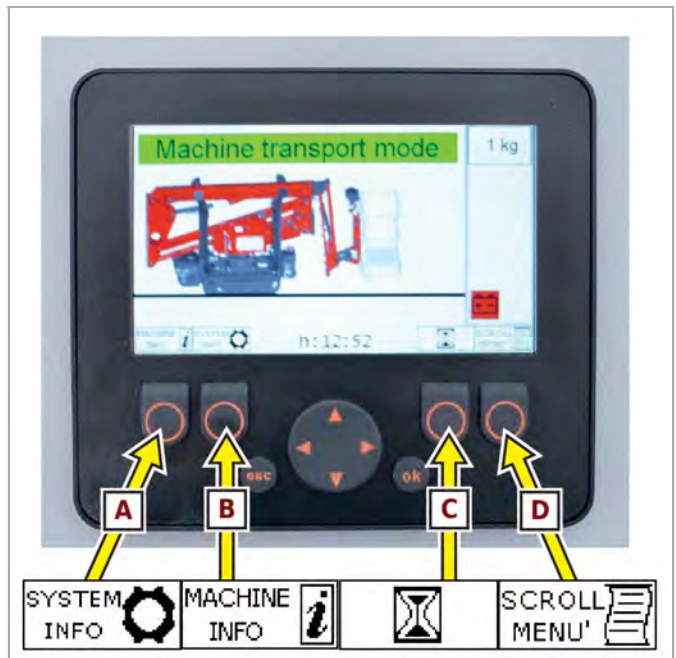

Depending on the current machine state, the screen corresponding to the current machine configuration appears on the display:

Introductory page.



Machine in condition for transport.  
All the stabilisers are recognised as being raised and the aerial part is closed.



Machine stabilized and levelled ready for work.



Machine operative.

The machine is stabilised, levelled with the aerial part extended.

The graph shows, with an arrow and in percentage, the reach limitation of the platform.

When the percentage reaches **100%**, the screen changes automatically.



Machine levelling (As soon as the machine enters the work limits the red telltale turns green).



The support and the push to the ground of all the stabilizers.



Machine with superstructure not recovered.



### 5.11.1. DESCRIPTION AND USE OF THE KEYS

#### Button A

By pressing the button **A** it is possible to consult a summary page that describes the type of platform in use.

In particular there is information regarding:

- Type of machine.
- serial n°.
- Versions with software installed.
- Supply voltage.
- Main motor.
- Secondary emergency motor.



### Button B

If key **B** is held pressed, a screen can be viewed displaying a self-diagnosis of the machine to use the carriage (Superstructure stowed).



### BUTTON C

By pressing the button **C** it is possible to analyse the hours the platform has been operating, distinguishing the use of the two motors with which it is equipped.

- Main motor
- Secondary motor (Electric or internal combustion)

**!** **Note**

When the motor is started, the hourglass shown on the display flashes.



### Button D (Scroll)

The first press (and release) of the scroll key introduces the user to a scrolling menu that allows you to display the state of the sensors with which the platform is equipped.

See section **5.11.3**:

“Sequences of screenshots”.

After the button has been pressed once, you can move in the menu with:

- Repeated pressing of the scroll key (Button **D**).
- Use of the directional arrows (Button **E**).

The menu is exited at the end of the screens or when keys "**ok**" / "**esc**" are pressed.

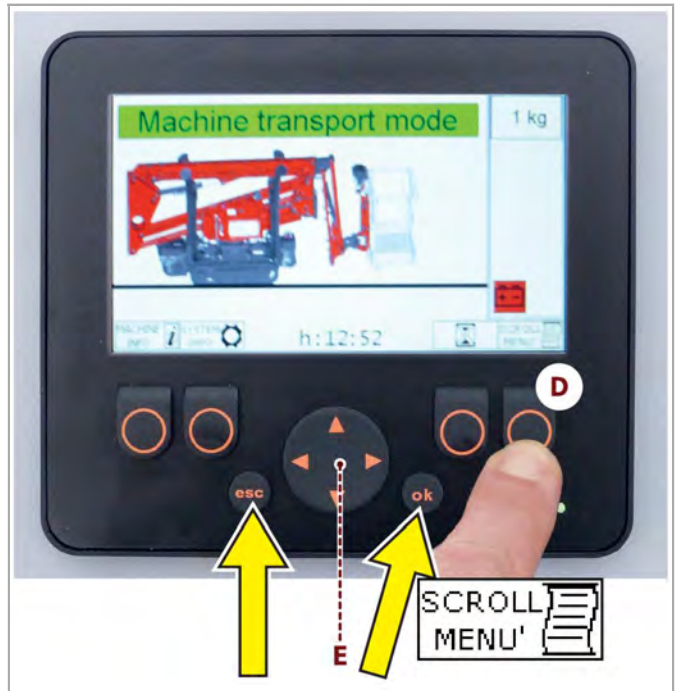

### 5.11.2. SEQUENCES OF SCREENSHOTS

When key **D "Scroll"** is pressed the following screens are displayed in order:



“Stabilizer sensors” page.

When at least one stabiliser touches the ground, this screen appears.

Next to each stabiliser, the green tick (✓) appears when it is acknowledged to be on the ground.

When the **4** stabilisers are correctly placed, the screen disappears automatically.



Planarity sensors screen.

This signal appears when all four stabilizers are on the ground and the superstructure is stowed.

The mark indicates the position detected by the system.

If the indicator is green, the platform is levelled within the allowed limits, otherwise the indicator is red.



Basket load cell screen.



Superstructure sensors control screen.

- 1 - Column centre.
- 2 - Superstructure resting.
- 3 - Microswitch detecting the pushbutton panel in the basket.



Pressure sensors check screen.



Machine fully stowed condition screen.



“General diagnostics” page.



Diagnostics of electric motor with lithium battery (If present).



### 5.11.3. MESSAGES LIST

During normal use of the platform the display shows some screens that:

- The summarise the state of the machine as recognised by the control system.
- They indicate errors with the electrical system.

#### Error messages



#### **Remote control not correctly positioned or incorrect position of the command enabling key.**

The remote control presence sensor in the basket does not detect its presence.  
Or the base/basket command enabling key is not in the basket command enabling position.

## 6. DEVICES

### 6.1. SAFETY DEVICES

A number of safety devices are installed on the machine for the safety of the operator and the protection of the machine.



#### Caution

Do not tamper with, disconnect, bypass or remove any of the machine's safety devices or guards. The Manufacturer declines all responsibility for machine safety if this instruction is not observed.

#### 6.1.1. BASKET LOADING CELL (SQ43)

Measures the load inside the basket.  
The red indicator light and the intermittent acoustic signal warn that the maximum permitted load in the basket has been exceeded.  
Exceeding the limit blocks machine movements.



#### Note

To re-start normal functioning, the excess load must be removed from the cage.

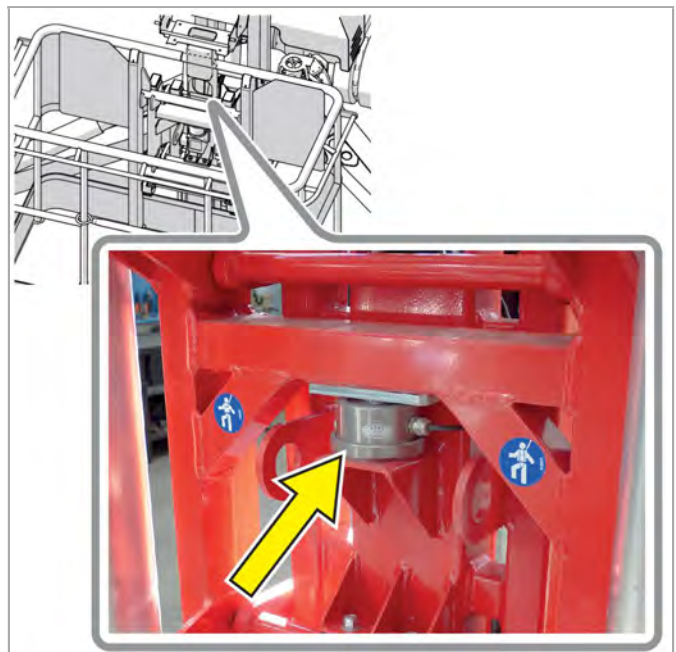

#### 6.1.2. STABILISER FEET GROUND PRESSURE SENSORS (SQ121- SQ122 - SQ123 - SQ124)

Each stabiliser foot is equipped with a sensor that controls the correct position of the stabiliser on the ground.  
The lack of ground pressure of a stabilizer foot is signalled on the display.



### 6.1.3. MICROSWITCH DETECTING THE PUSHBUTTON PANEL IN THE BASKET (SQ49)

The support of the pushbutton panel in the basket is equipped with a microswitch which detects its presence.

Positioning the pushbutton panel in the support enables the operation of the movements of the aerial part.

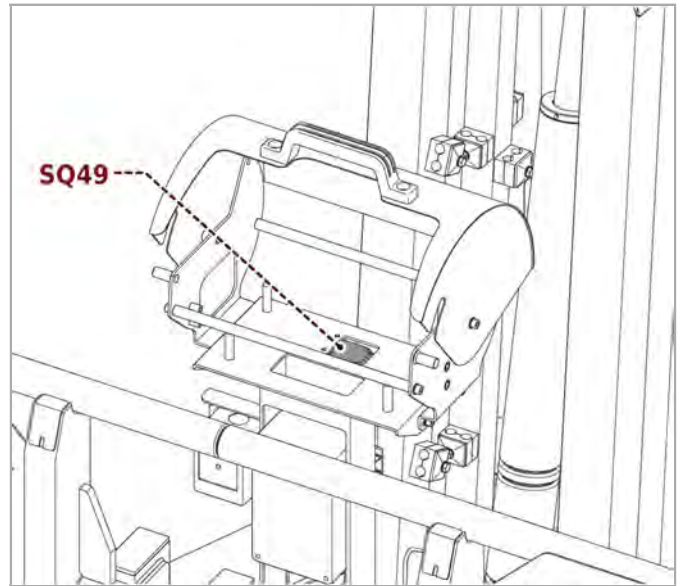

### 6.1.4. HORN (HA85)

Acoustic signal device (horn) that activates automatically intermittently every time that the machine moves.

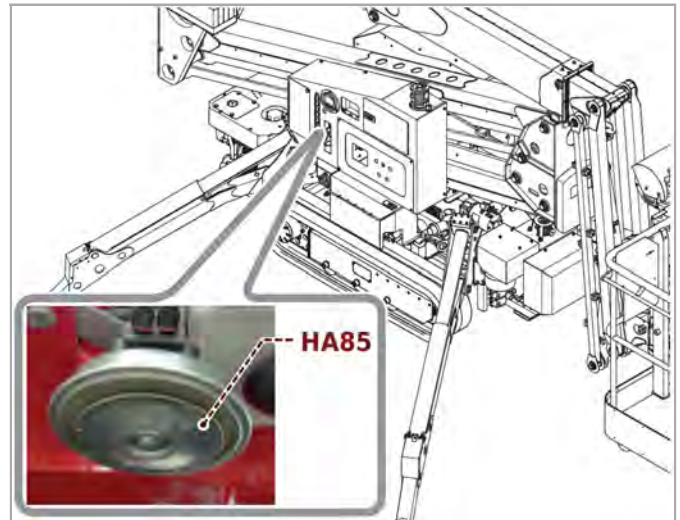

### 6.1.5. OPTICAL WARNING DEVICE (LUMINOUS COLUMN)

#### HL89a Red light

The telltale lights up each time there is a warning.

#### HL89b Orange lamp

The telltale lights up when the machine is operational.

#### HL89c Green light

The lamp comes on with a fixed light when the aerial part is in a safe position.

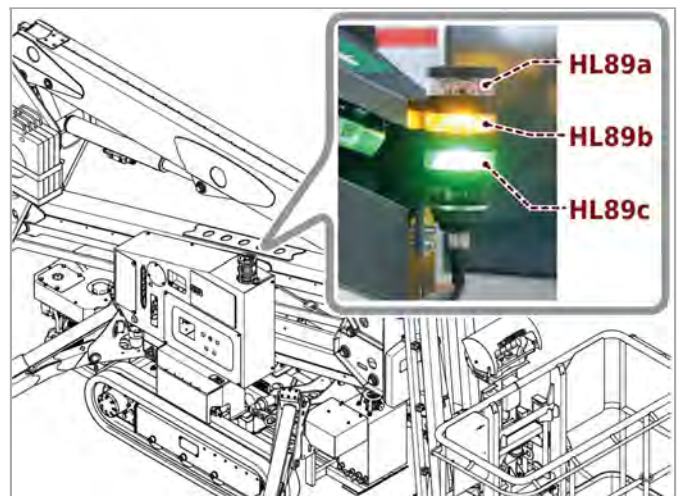

### 6.1.6. EMERGENCY BUTTON

Each control station is equipped with a device (**SB40A, SBT, SB40**) that allows the operator to stop the machine in the presence of imminent danger.

The buttons (**SBT**) pressed, prevent the commands of the respective consoles.

The buttons (**SB40A - SB40**) pressed, prevent the operation of all commands.

Push the emergency red mushroom like button to stop every movement.

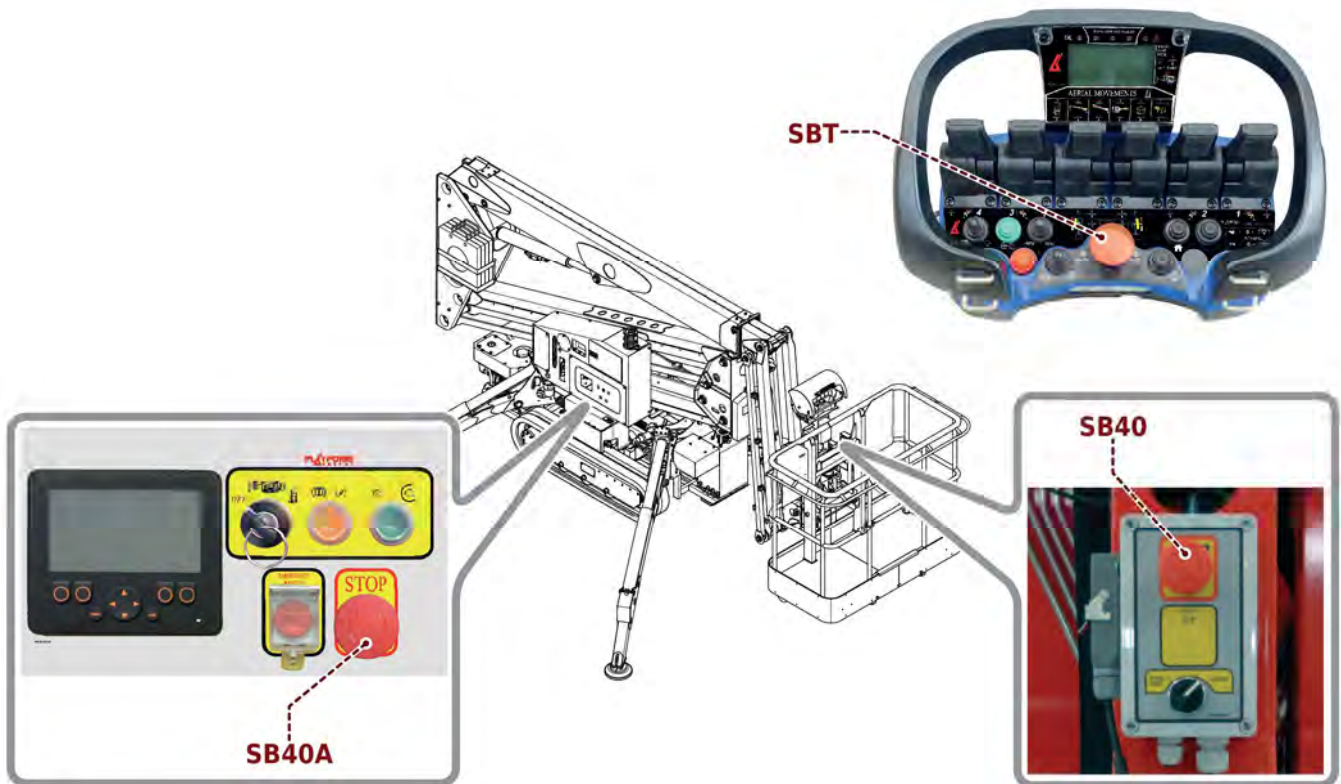

To restart the machine reset:

- The work conditions;
- The safety conditions;
- The emergency stop device by twisting the button head in the direction shown by the arrows marked on it.

Check the efficiency of the safety device before each use of the machine:

- Give energy to the power system;
- start a work cycle;
- Press pushbutton.

The device is efficient, if the movement stops.

The check must be carried out on all emergency devices present in the command position.

If the device is irreparably damaged and all attempts to restore the working configuration are unsuccessful, contact the service centre for information on how to reset the device and the machine.

### 6.1.7. INCLINATION CONTROL

The inclination sensor (**SQ154**) electronically controls the inclination of the machine.

When the maximum allowed tilt limit has been exceeded the indicator light (**HL89a**) comes on.

Machine levelling (X and Y axes) is visible on the control board display.

The “NO LEVEL” message appears on the pushbutton panel display.

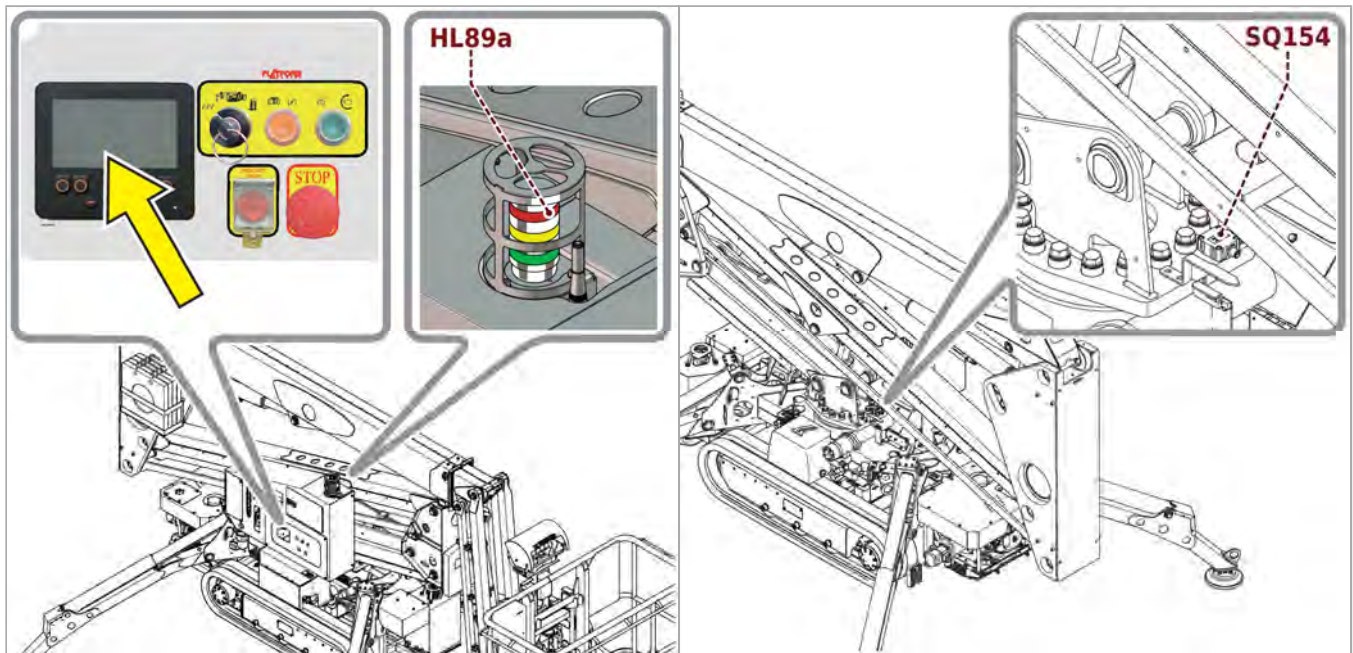

### 6.1.8. MANUAL EMERGENCY PUMP

The machine has a manual emergency pump in the cases in which there is a failure that determines a total machine block (See **9.16.** “emergency movements”).

In addition to the hand pump, upon request an additional **12 V** electric pump can be installed, having the same function as the manual pump, which exploits the tension of the batteries used to start the combustion engine.

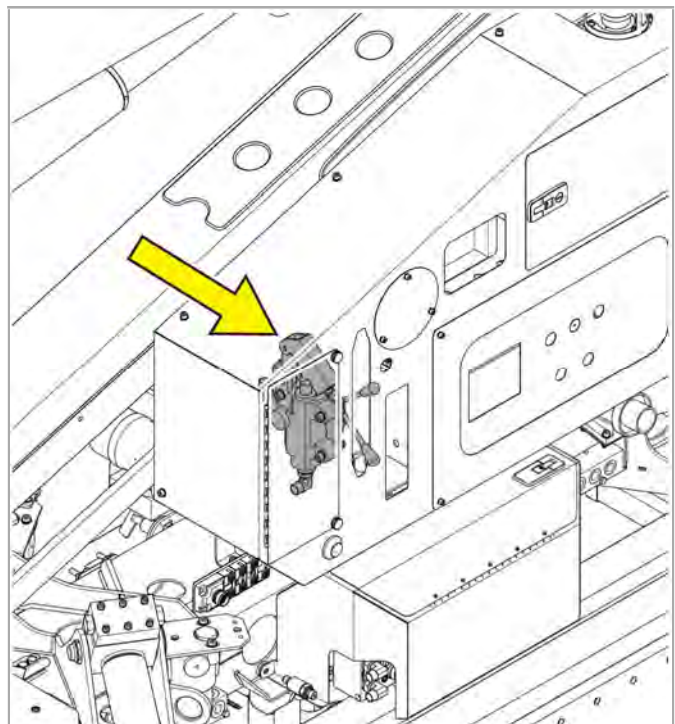

### 6.1.9. SUPERSTRUCTURE SENSOR RESTING

With the column centred, the sensor **SQ77** detects that the machine superstructure is resting:

- Boom extension fully returned.
- Upper arm resting.
- The jib fully closed.

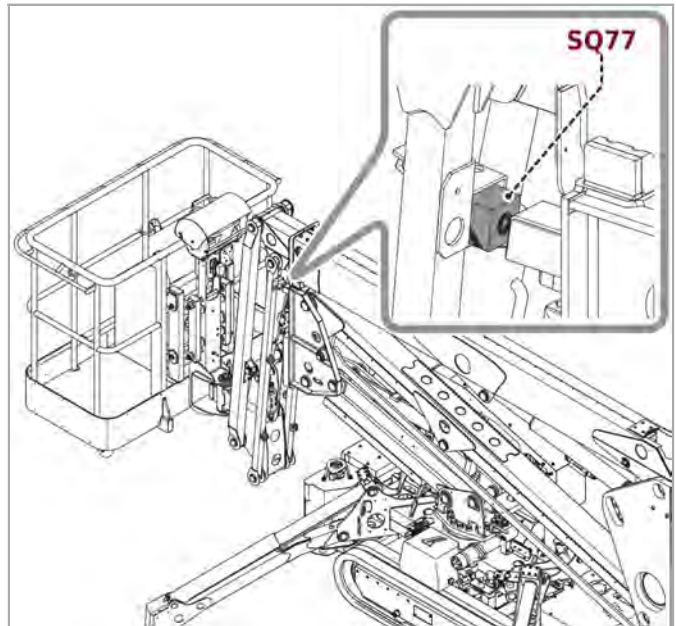

### 6.1.10. ROTATION CHECK

The rotation of the turret is **360°** non-continuous (approx. **180°** on the right-hand side and approx. **180°** on the left-hand side).

The device is composed of a by-pass valve **(A)** which intercepts the plate **(B)**, blocking the rotation at **180°**. When the machine is blocked during rotation, to reset it, it is necessary to rotate the turret in the opposite direction to the one which generated the block.

There is also a sensor on slewing to indicate turret closure position.

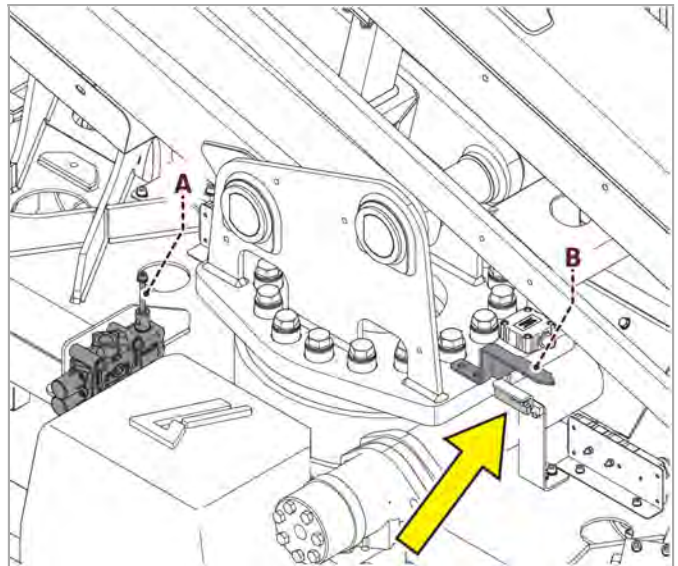

## 7. OPTIONAL

### 7.1. ACCESSORIES AVAILABLE UPON REQUEST

Description	D - B	E	ED - EB
Anti traces continuous track	*	*	*
12 VDC emergency electric pump kit	*	**	*
Work lamp in the basket	*	*	*
Tele-diagnostics and gps localisation device	*	*	*
Anti-collision system	*	*	*
Oversized plates for stabilisation	*	*	*
Biodegradable hydraulic oil	*	*	*
Lubricant kit for arctic climate	*	**	*
Single-seater aluminium basket	*	*	*
Electric pump 110-230V	*	**	**

**Key:**

- \* Included
- \*\* Not provided

## 8. TRANSPORT

### 8.1. FOREWORD

The following chapter contains important prescriptions that must be strictly observed to protect personal safety.

Always observe also all the general and specific regulations concerning lifting equipment and handling and transport operations, including those that are not expressly stated in this manual.



#### Caution

The manufacturer's technicians are not qualified to use the lifting equipment or to supervise the work of third parties from a safety point of view.

The customer must therefore provide our technician with qualified personnel equipped with suitable lifting means.

The manufacturer declines all liability related to the use of unsuitable lifting means.

The machine is equipped with **6** eyelets (**A - B - C**) through which the straps/chains must be passed to block the machine.

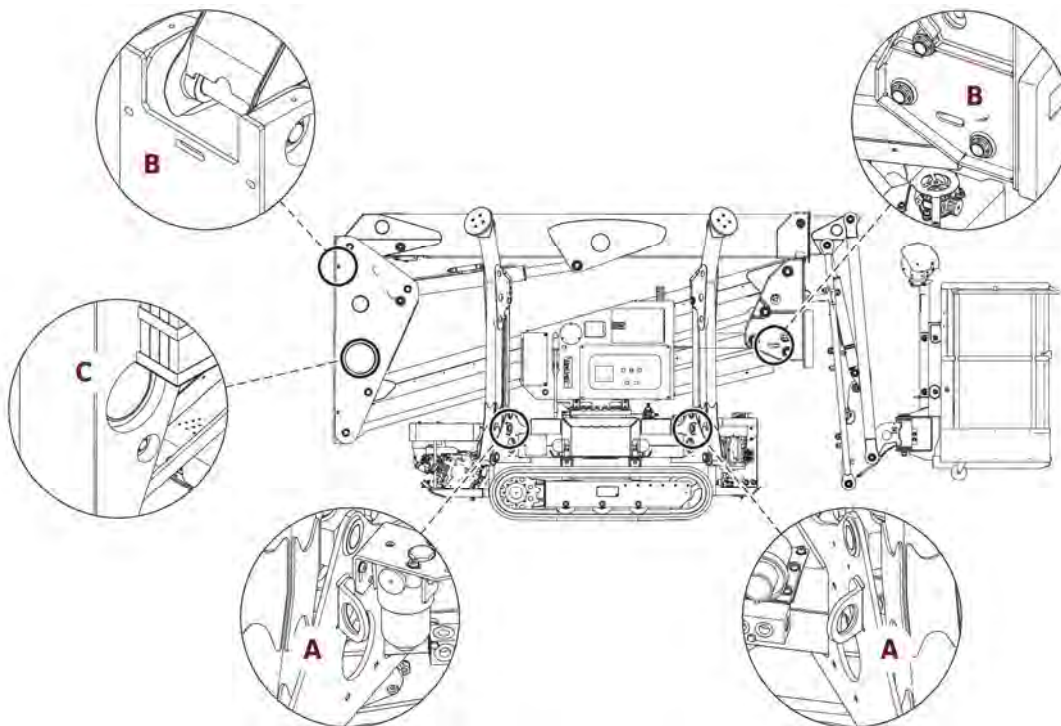

### 8.2. SAFETY PRESCRIPTIONS FOR TRANSPORT AND HANDLING OPERATIONS

The transport, lifting and assembly operations must be carried out by specialised companies working in the machinery transport sector;

It is only possible to perform the various operations in conditions of safety when suitable skills are combined with the use of the correct equipment.

During lifting procedures:

- use the utmost caution;
- keep all persons clear of the area of operations;
- do not allow persons to walk or stand under or in the vicinity of suspended loads;
- lift loads to the indispensable minimum height;

- move loads close to the ground at low speed and taking care to avoid impacts and jolts;
- keep the manoeuvre area free of materials and clutter;

**Danger**

All personnel, including the operator, must remain at a safe distance.

The definition of a safe distance must take account of the situation of the greatest danger that may arise during an exceptional event, such as breakage of a lifting chain or eyebolt with consequent tipping of the load.

No personal protection device exists able to protect against this event.

Always take account of this hazard and ensure that no one is in the vicinity of the area of manoeuvring or in line with the direction of the ropes or chains.

While lifting and transporting the machine take due account of the size of the spaces available and the ground characteristics.

**Caution**

Never climb onto the machine or parts of the machine, even if the machine is open and disconnected from the energy sources.

Before starting lifting operations ensure you are wearing the following personal protective equipment (PPE)

- Protective helmet.
- Cut-resistant gloves.
- Accident-prevention footwear with slip-proof sole and reinforced toe-cap.

### 8.3. FASTENING THE MACHINE FOR TRANSPORT ON THE VEHICLE

Whenever the machine is transported on a vehicle, it is mandatory that its fastening be carried out by the transporting operator.

- It is obligatory for the machine to be fixed to the vehicle body, whenever it is transported from one work site to another.
- It is forbidden to transport the machine loose or free to move.
- It is prohibited to transport the machine hooked in points different to those provided for and indicated here, and with a sling/chain tensioning force different to that specified.
- To secure the base of the machine, the slings/chains must be hooked to the dedicated points **(A)**.

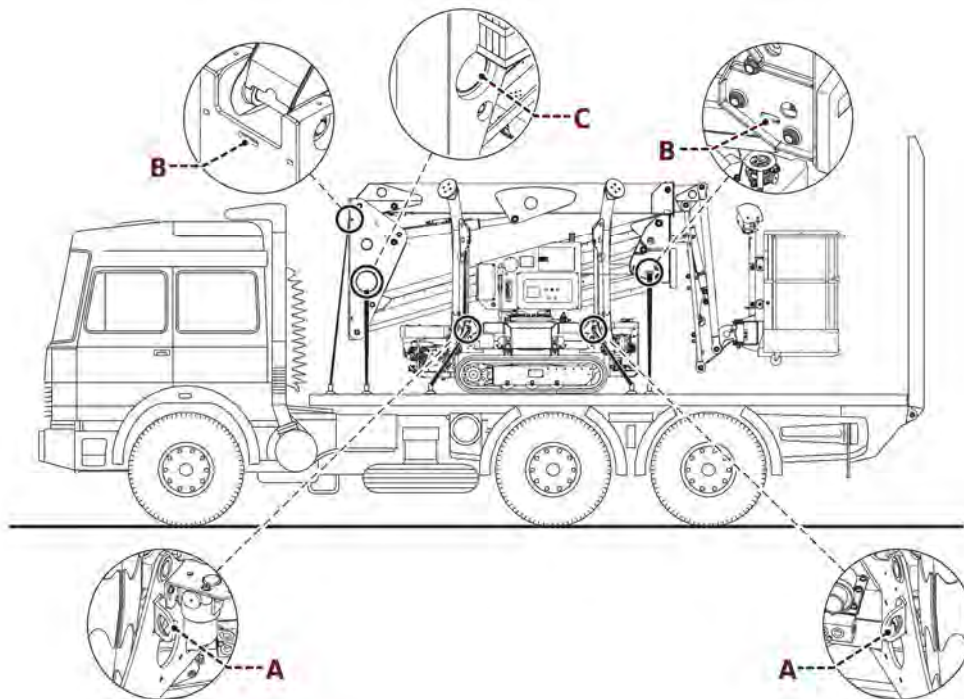

- It is nevertheless necessary to hook the tie rods in the opposite corners of the machine, so as to equalize the tension applied to the axis.

**⚠ Caution**

Apply a pulling force equal to **100 kg** and not beyond, so as not to damage the frame.

- In addition to lateral movements, it is advisable to fasten the machine so as to minimize or eliminate oscillations and jolts.
- Hook the slings/chains to the eyelets **(B - C)** to reduce side oscillations.
- Pull the slings/chains with the same pull force used to keep the machine base still.
- Hook the slings/chains to keep the machine still.

## 8.4. LOADING AND UNLOADING BY RAMP



### Caution

Command machine shifting from the ground, maintaining a constant distance of at least **1 m** from the continuous tracks.

For ramps with tilts **14°÷18°** the basket must be dismantled or the jib must be slightly opened.

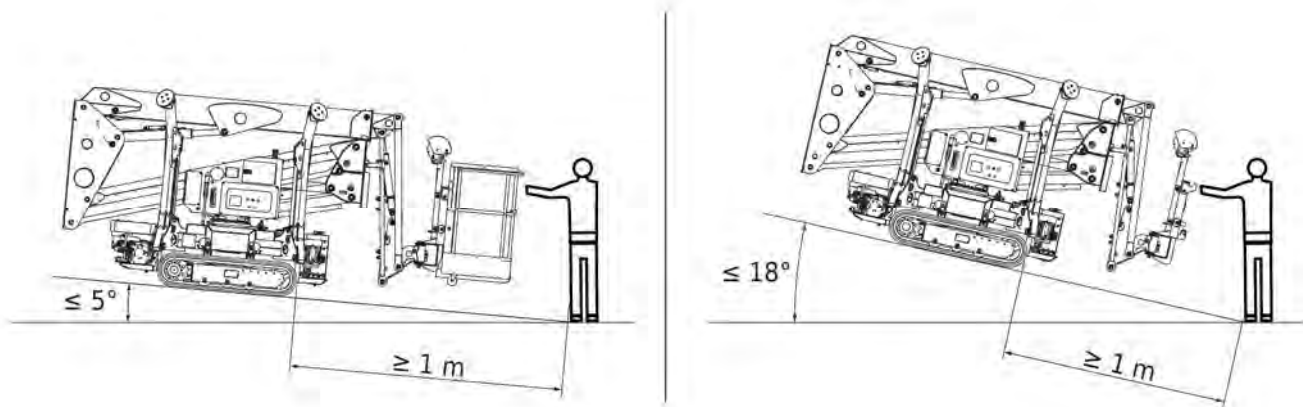

## 8.5. LIFT

The machine can be lifted, for both the loading and unloading phases, from a transport vehicle with the aid of a crane or overhead crane.

In this case, the machine will be lifted by appropriate capacity chains or wire ropes by hooking it to the perforated disks, as subsequently illustrated.



### Danger

Always check the efficiency and integrity of the wire ropes or lifting chains.

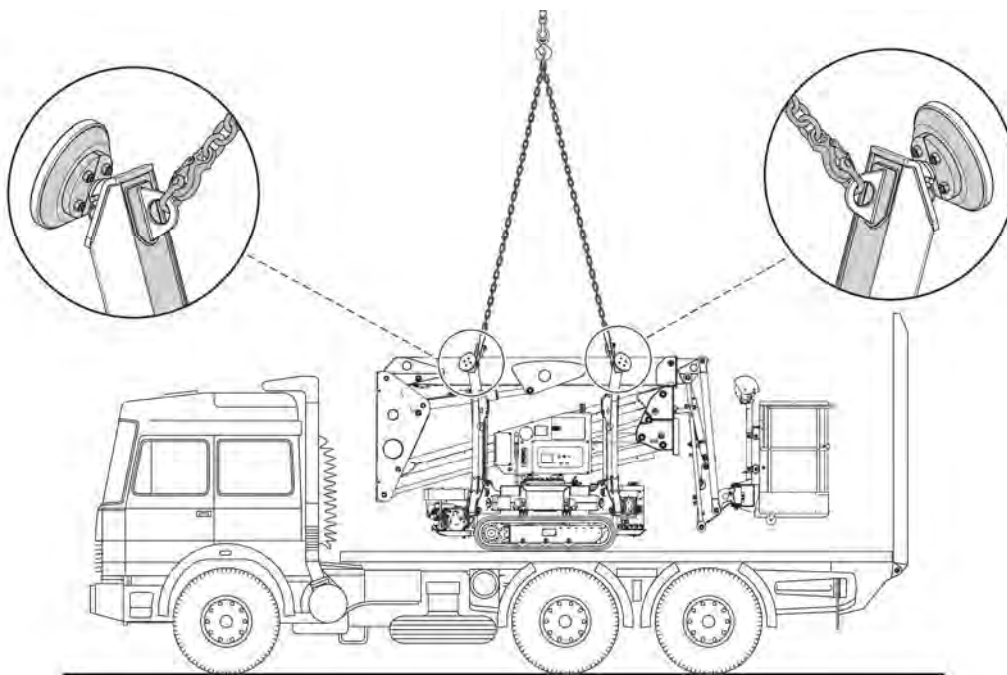

## 9. USE

### 9.1. FOREWORD

The sequence of main operations necessary to make the machine operational is as follows:

- **Shifting**
- **Stabilisation**
- **Aerial part movement**

There follow the instructions for safe configuration and use of the machine.

#### **Note**

The sequence of operations necessary to install the machine is affected above all by the operational situations.

According to the working conditions, the operator should adopt the safest and most suitable operational sequence.

### 9.2. RADIO CONTROL ACTIVATION

#### USE FROM GROUND

- Turn the switch **(SA40)** (ground control panel) to position **1**.
- Enable the pushbutton panel by releasing the emergency button **((SBT))**.
- Hold the **(SB2T)** start button down for **2 s**.  
The intermittent flashing of the green light **(HL2T)** of the pushbutton panel (transmitter) indicates the search for the contact with the receiver unit.  
The fixed red light **(HL1T)** indicates that the contact between the transmitter unit (pushbutton panel) and the receiver unit has occurred.
- Read the message displayed on the pushbutton display and act accordingly.

The pushbutton panel display shows:

- The working hours.
- The accumulator charging level.  
The minimum level is also shown by the intermittent flashing of the indicator light **(HL1T)**.
- The pages with functions which can be activated on the machine.
- The operating and alarm messages.

Press the button **(SB3T)** to change the page displayed.

To switch off the button panel, it is necessary to press the emergency button **(SBT)** which disables the use of the platform from the ground.



## USE FROM BASKET

- Turn the switch **(SA40)** (ground control panel) to position **2**.
- Place the button panel on the support in the basket.
- Check that the sensor **(SB49)** detects the presence of the button panel, enabling movement of the superstructure.
- Enable the pushbutton panel by releasing the emergency button **((SBT))**.
- Hold the **(SB2T)** startbutton down for **2 s**. The intermittent flashing of the green light **(HL2T)** of the pushbutton panel (transmitter) indicates the search for the contact with the receiver unit. The fixed red light **(HL1T)** indicates that the contact between the transmitter unit (pushbutton panel) and the receiver unit has occurred.
- Read the message displayed on the pushbutton display and act accordingly.

The pushbutton panel display shows:

- The working hours.
- The accumulator charging level. The minimum level is also shown by the intermittent flashing of the indicator light **(HL1T)**.
- The pages with functions which can be activated on the machine.
- The operating and alarm messages.
- Press the button **(SB3T)** to change the page displayed.
- To switch off the button panel, it is necessary to press the emergency button **(SBT)** which disables the use of the platform from the basket.

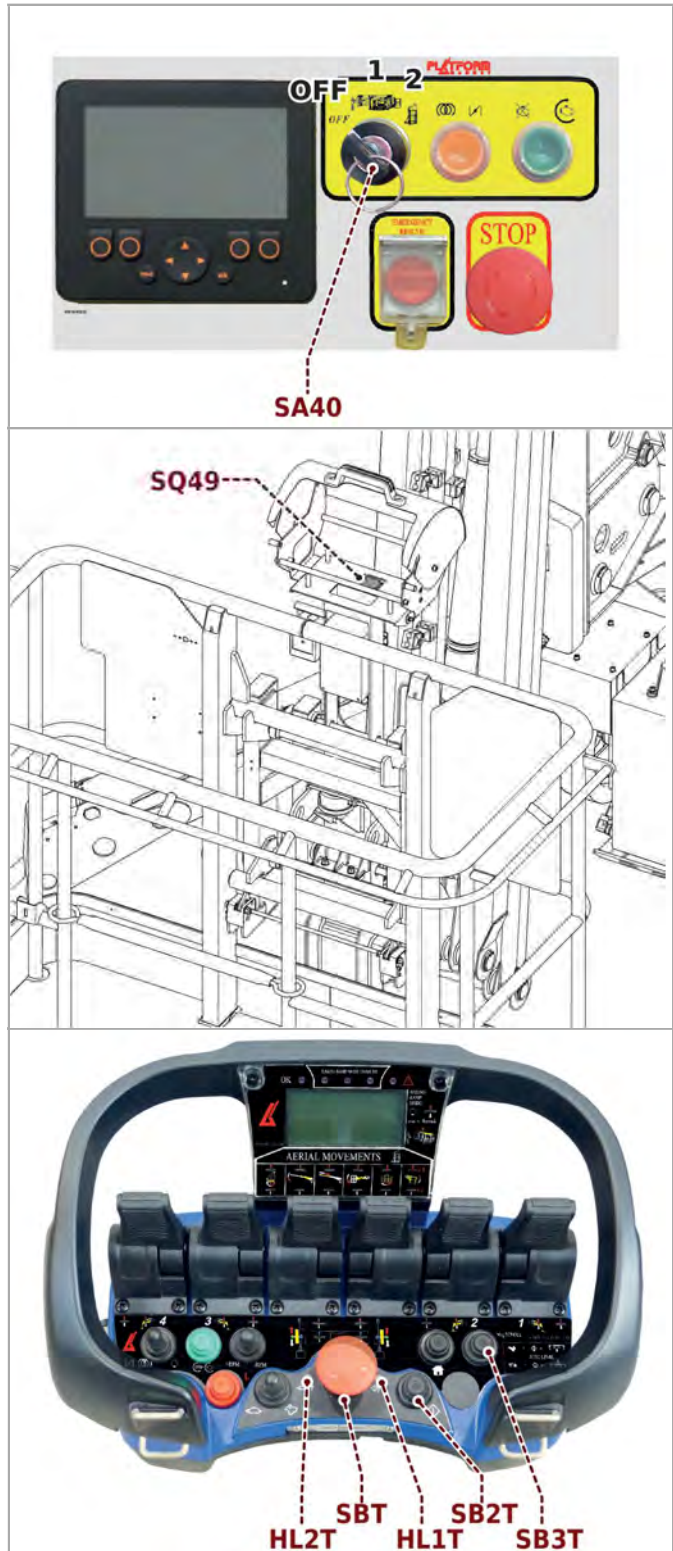

## 9.3. REMOTE CONTROL HARDWARE MANAGEMENT

The backlighting of the display can be activated on the remote control by moving the appropriate **(SA1T)** lever.

In the batteries saving logic, the back-lighting of the radio command has been limited to **10** seconds compared with **30** of the remote control.

## 9.4. START/STOP ENGINE

To optimise the work it is recommended that both engines are enabled (electric - internal combustion). The engine can be started and stopped from both the ground control panel and the radio control.



- Enable the internal combustion engine by turning the key of the battery cut-off switch to **(ST2 - a)** On.
- Insert the plug in the **230/110 V** outlet ((**PPG**)).
- Enable the start up of the electric motor from the circuit breaker (**Q3**) (See “Controls and tools on the machine”).
- Select the engine to be used using the selector switch (**SA89**) in the cage.



### Caution

The engine can only be selected using the selector switch (**SA89**) in the cage.

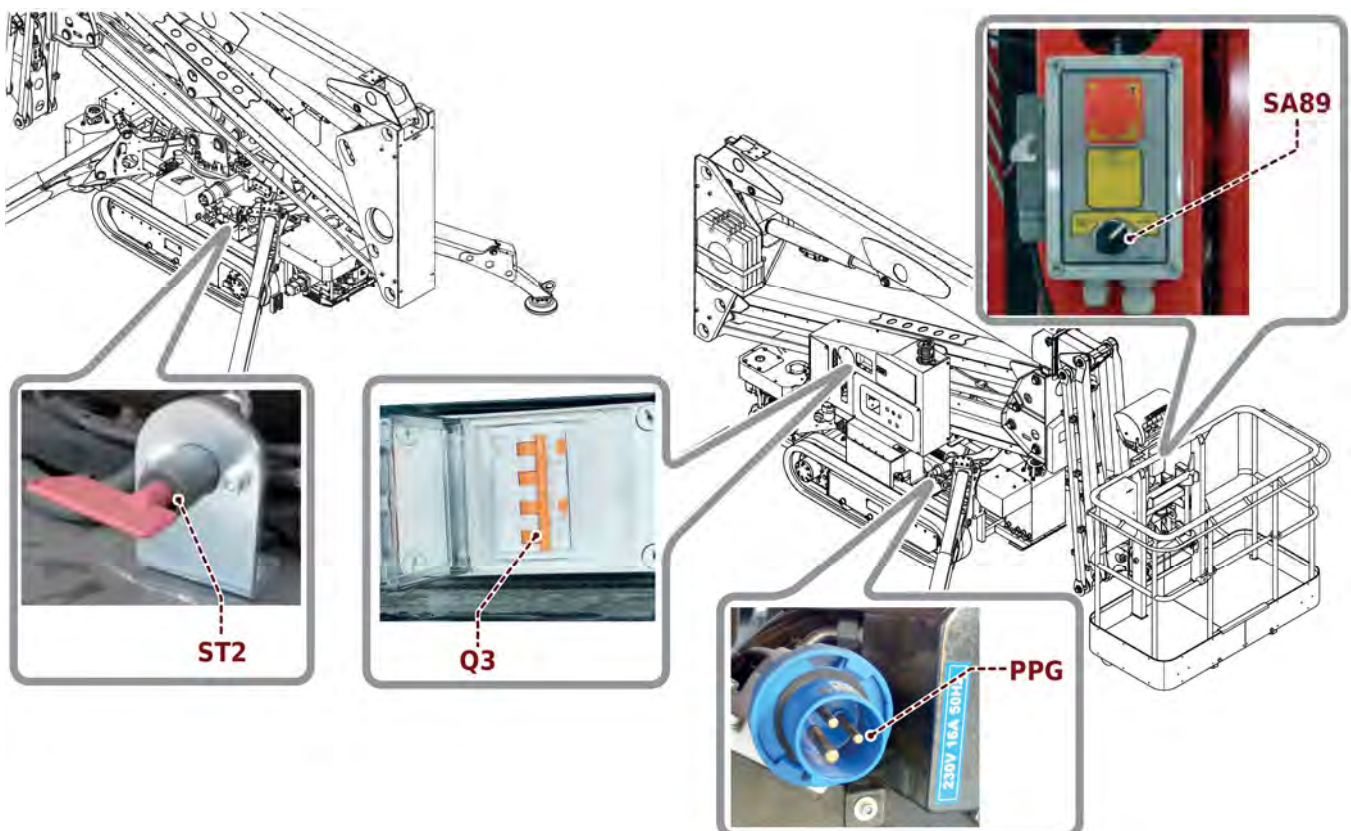

### 9.4.1. STARTING THE PETROL ENGINE

- Go to the basket and enable the use of the internal combustion engine using the selector (**SA89**).
- Move to "Ground control panel".
- Move the switch (**SA40**) to "ground position" or "basket position" according to the machine's operating situation.
- Press the motor ignition button (**SB52**) (ground control panel) or the switch (**SB1T**) (remote control push-button panel).



### 9.4.2. TURNING THE PETROL ENGINE OFF

- Check that the machine configuration is in maximum safety conditions.
- Press the motor shut-down button (**SB52**) (ground control panel) or the switch (**SB1T**) (remote control push-button panel).



### 9.4.3. STARTING THE DIESEL ENGINE

- Move to "Ground control panel".
- Move the switch **(SA40)** to "ground position" or "basket position" according to the machine's operating situation.
- Select the diesel engine using the **(SA89)** (Selector switch in the cage)
- Press the **(SB53)** button/indication preheating glow plug switch (ground control panel) or the **(SA1T)** switch (remote control panel).  
The indicator light **(SB53)** stays on until pre-heating has ended.
- Wait until the indicator lights **(SB53)** go off;

**The engine cannot be turned with the indicator light on.**

- Press the **(SB52)** engine ignition switch (ground control panel) or the **(SB1T)** switch (remote control panel).



**Note**

Starting the engine again immediately (while the engine is still hot) does not require the glow plugs to be pre-heated.



#### 9.4.4. TURNING THE DIESEL ENGINE OFF

- Check that the machine configuration is in maximum safety conditions.
- If the commands on the ground are enabled, it is possible to stop the diesel engine by holding the button **(SB52)** (control board on the ground) or **(SB1T)** (radio control pushbutton panel);

**!** **Note**

Starting the engine again immediately (while the engine is still hot) does not require the glow plugs to be pre-heated.

- When the manoeuvre has been completed, take the switch **(SA40)** to "off".
- Disable the engine by rotating the key in the battery disconnecter **(ST2)** to off.



### 9.4.5. STARTING THE ELECTRIC MOTOR

- Insert the plug in the **230/110V** outlet ((**PPG**)).
- Enable the start up of the electric motor from the circuit breaker (**Q3**) (See "Controls and tools on the machine").
- Turn the switch (**SA40**) (ground control panel) to "workstation in basket".
- Go to the basket and enable the use of the electric motor via the selector (**SA89**).
- Move to "Ground control panel".
- Move the switch (**SA40**) to "ground position" or "basket position" according to the machine's operating situation.
- Press the motor ignition button (**SB52**) (ground control panel) or the switch (**SB1T**) (remote control push-button panel).



#### Caution

While the machine is being shifted, check that the cable and connection of the electric plug in the electric socket are not damaged.

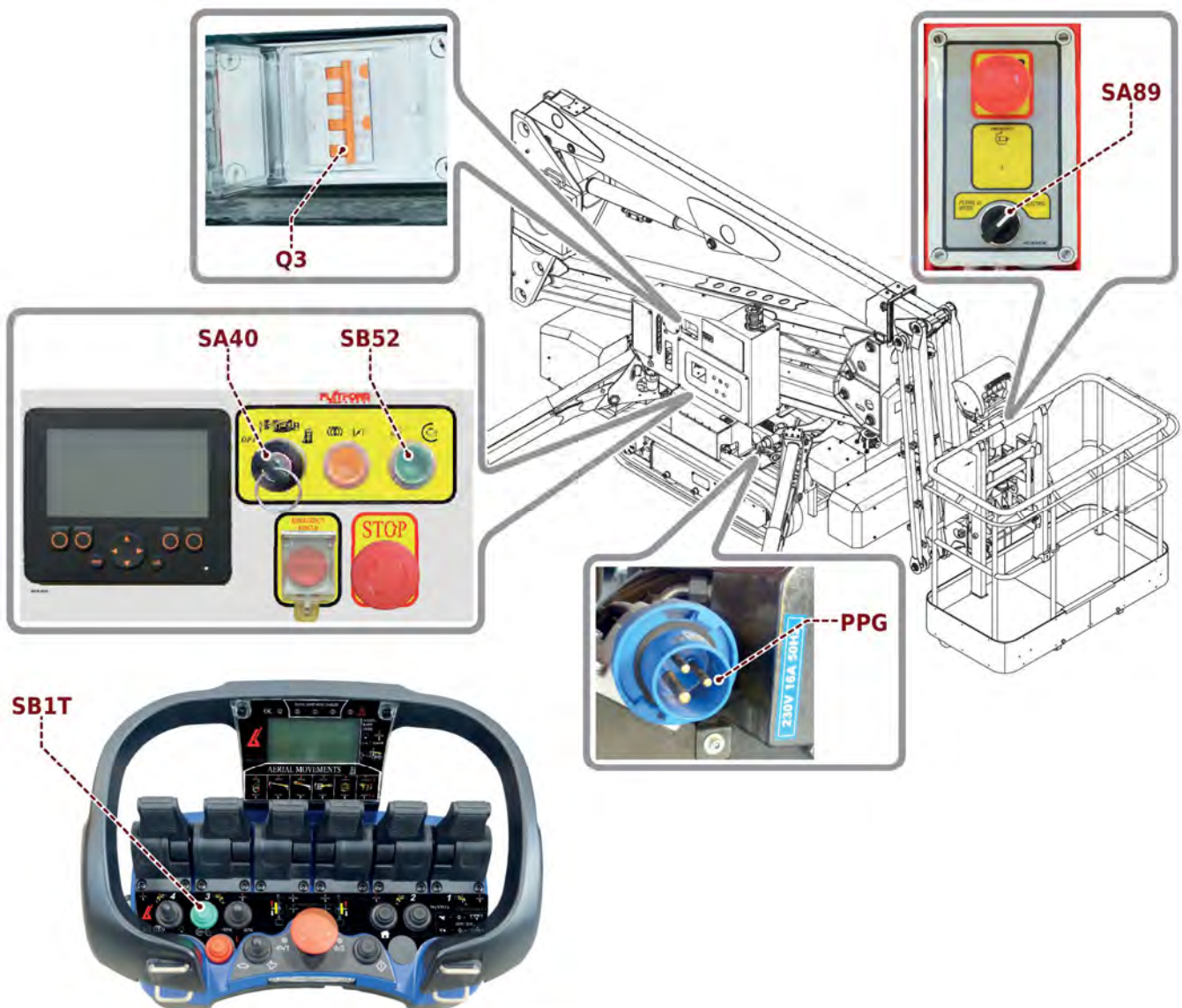

### 9.4.6. TURNING THE ELECTRIC MOTOR OFF

- Check that the machine configuration is in maximum safety conditions.
- Press the motor shut-down button **(SB52)** (ground control panel) or the switch **(SB1T)** (remote control push-button panel).
- Disable the electric motor using the circuit breaker **((Q3))**.
- Disconnect the plug from the outlet **((PPG))**.

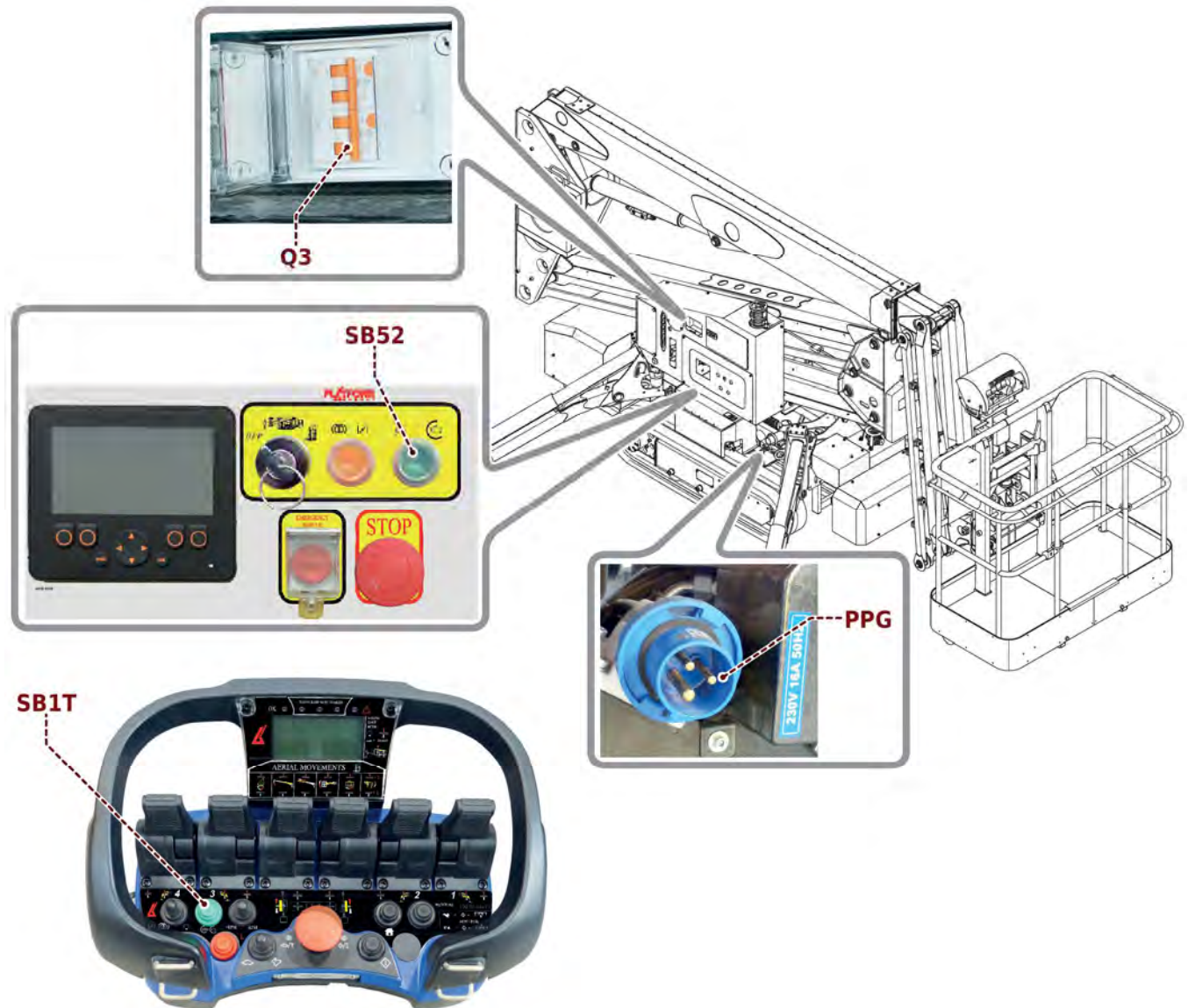

## 9.5. STABILISING THE MACHINE



### Caution

Stabilisation can be carried out from the “manual carriage handling controls” ground position and via the remote control, which is normally used by the operator on the ground.

A trained operator must be present on the ground during aerial movements. he must perform any emergency manoeuvres required and monitor the regular performance of jobs.

Stabilisation is allowed with a maximum basket load of **40 kg**.

- Perform the operation on all the stabiliser feet.
- Start the engine (see **9.4.** “start/stop engine”).
- Move the switch (**SA40**) to “ground position”.
- The stabilisation is carried out by remote control, move away from the machine by about **1** metres.
- Use the pushbutton panel levers (**JT1, JT2, JT5, JT6** - see **5.2.** “Remote control”) to activate the opening of the jacks on the individual stabilizer feet.  
Automatic stabilisation can be carried out.  
See section **9.8.** (Automatic stabilisation enabling).





**Note**

The numbers which mark the pushbutton panel levers correspond to the number affixed to the stabiliser feet.

During the stabilisation phase, the buzzer emits an intermittent acoustic signal.

- Continue opening the stabiliser feet jacks until the machine is lifted off the ground. It is recommended to lift it by about **210 mm** from the ground. At the end of stabilisation, the orange indicator lights on the stabilisers continue to flash.

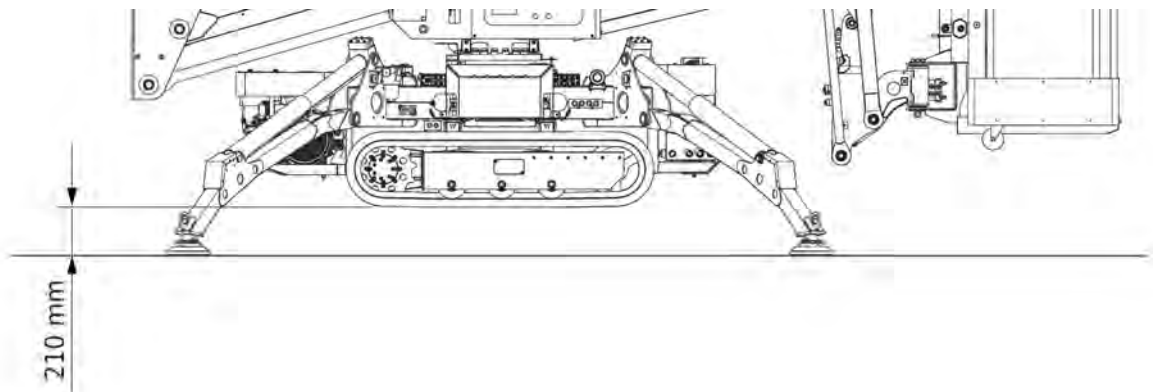

- Level the machine and perfect stabilisation with the help of the spirit level that appears on the display of the control board (**SQ144**).



**Note**

An electronic spirit level electronically checks the planarity of the machine.

If the indicator light (**HL89a**) is on, it is possible to check along which axle the maximum allowed inclination was exceeded.

Press the "change page" button (**SB3T**) (see 5.2. "remote control") until the page regarding the inclination of the axles **X** and **Y** appears.

The red indicator (**HL89a**) on the illuminated column goes off if machine levelling is within a gradient of **1°**.

When stabilisation is complete the green telltale (**HL89c**) lights up fixed and the message "Stabilisation ok" appears on the remote control display.

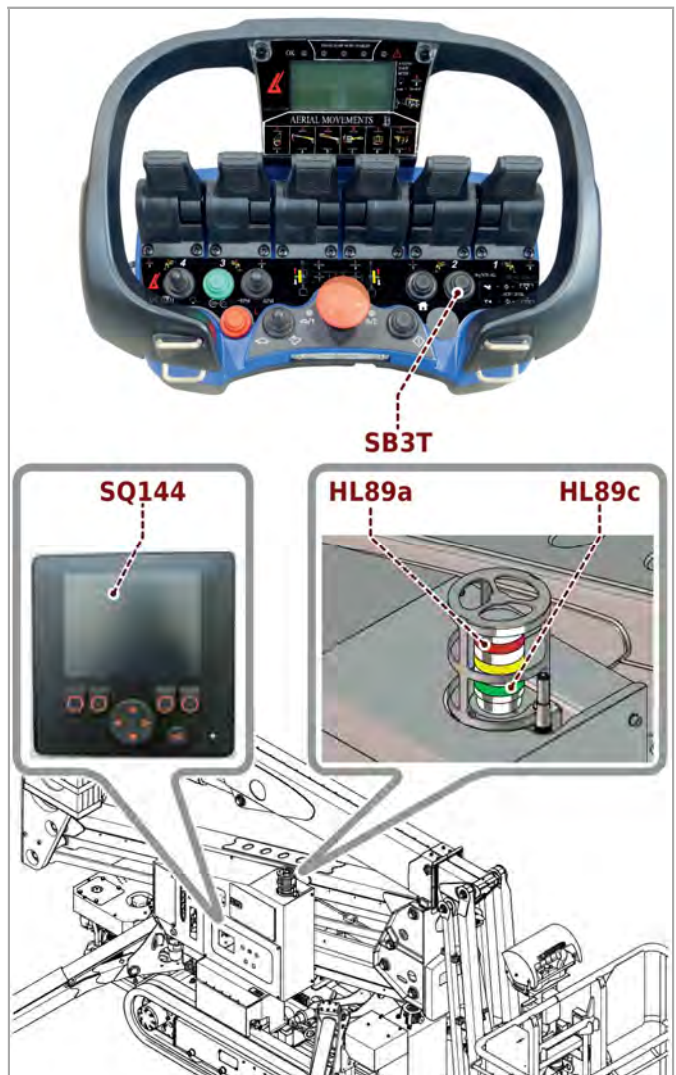

## 9.6. STABILISATION CLOSING



### Caution

Perform the stabilisation closure operations with the aerial part in complete safety conditions on the booms column.

- Start the engine (see **9.2.** "start/stop engine").
  - Move the switch (**SA40**) to "ground position" (See **5.1.** "control panel on the ground").
  - If necessary, retract completely with the tracks (see **9.10.** "Extension/return of the tracks").
  - Move at least **1** metre away from the machine.
  - Use the pushbutton panel lever to control the closure of the jacks of each individual stabiliser foot (**JT1, JT2, JT5, JT6**) (See **5.2.** "remote control").
- Stabilisation return can be automatically carried out.  
See section **9.9.** (Automatic stabilisation return).



### Note

The numbers which mark the pushbutton panel levers correspond to the number affixed to the stabiliser feet. During the destabilisation phase, the buzzer emits an intermittent acoustic signal.

- Perform the operation on all the stabiliser feet.
- Move the switch (**SA40**) to "OFF" (See **5.1.** "control panel on the ground").

## 9.7. AERIAL PART MOVEMENT (OPENING)



### Caution

The machine must be stabilised, raised from the ground and levelled before moving the aerial part.

- Start the engine (see **9.4.** "start/stop engine").
- The aerial part is normally moved by the operator in the basket. It is therefore, necessary to move the switch (**SA40**) to "basket position".
- Place the button panel on the support in the basket.  
Check that the sensor detects the presence of the button panel, enabling movement of the superstructure.
- If the superstructure needs to be moved from the ground, the emergency commands need to be operated by pressing the oil call switch.
- Climbing into the basket.
- Check that the sliding bar which protects the opening of the basket is closed and positioned correctly.
- Attach the safety belt to the safety ring.
- Command the (**JT5**) "jib" movement to move away from the carriage.
- Control the (**JT2**) lifting of the pantograph arm.
- Turn the column (**JT1**) in the direction of the point of work.
- Lift the telescopic boom (**JT3**).
- Refine search for the precise work point by moving (**JT4**) extension.

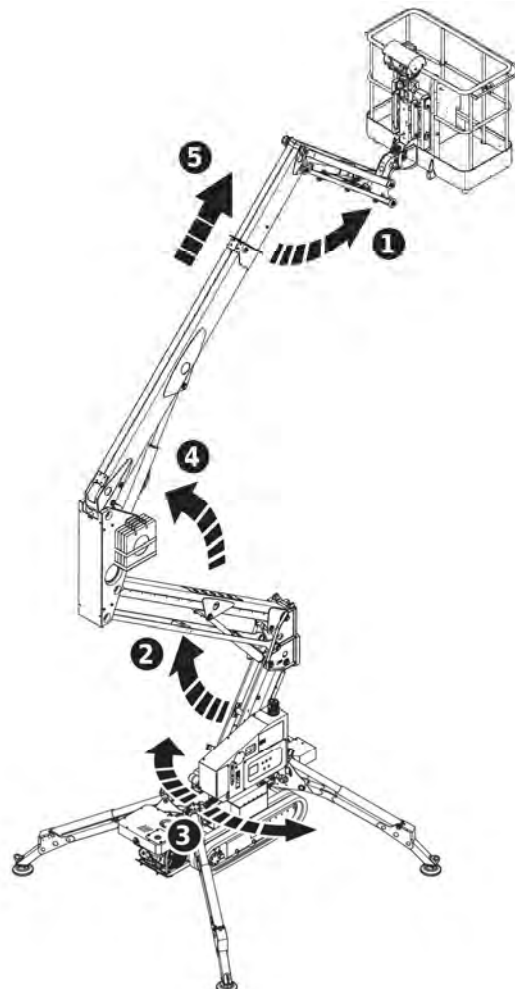

## 9.8. AERIAL PART MOVEMENT (CLOSING)

### ! Note

It is possible to use all combinations to close the superstructure, but it is advisable to follow these phases.

- Rotate the column to place the telescopic arm in axis with the machine.
- Retraction with the extension.
- Lower the telescopic boom.
- Lower the pantograph boom.
- The green light comes on (**HL129c**).
- Close the antenna.
- Proceed with closing the stabiliser feet (See **9.6.** "stabilization closing").
- Detach the safety belt from the safety ring.
- Get out of the basket.
- Turn the engine off (see **9.4.** "start/stop engine").



HL89c

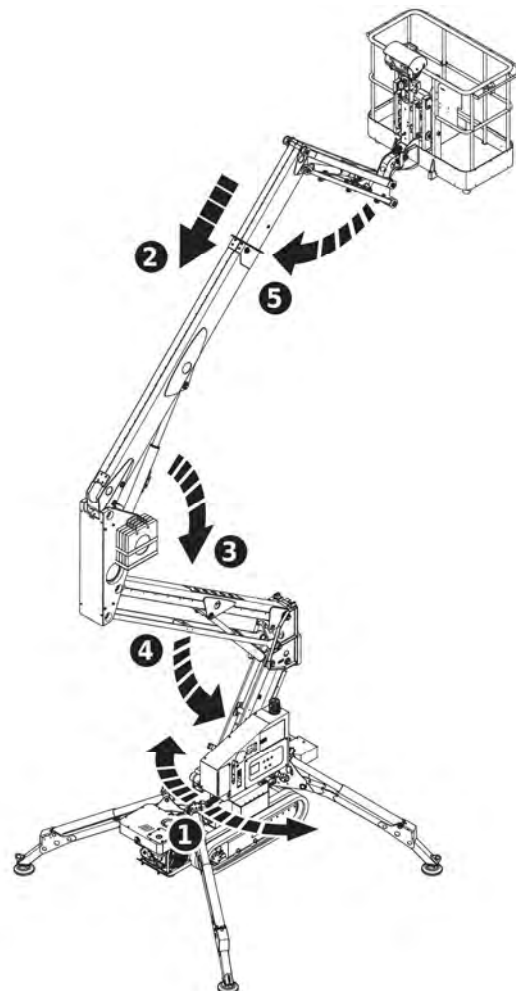

## 9.9. AUTOMATIC STABILISATION ENABLING

- Start the engine (see **9.4** "start/stop engine").
- Move the switch **(SA40)** to "ground position".
- Move away from the machine by at least **2** metres.
- Press button **(SB2T)** and button **(SA3T)** to the right at the same time to activate automatic levelling.



### Note

- During the levelling and stabilisation phase, the buzzer emits an intermittent acoustic signal.
- At the end of levelling, the red indicator light on the illuminated column **(HL89a)** must be off.



## 9.10. AUTOMATIC STABILISATION RETURN

**! Note**

The automatic retraction of the levelling cannot be activated in the cage.

- Remove the remote control from the support in the basket.
- Move the switch (**SA40**) to "ground position".
- Start the engine (see **9.4** "start/stop engine").
- Move away from the machine by at least **2** metres.
- Press button (**SB2T**) and button (**SA3T**) to the left at the same time to activate automatic retraction of the levelling.

**! Note**

- During the destabilisation phase, the buzzer emits an intermittent acoustic signal.
- The destabilization procedure is considered complete as soon as the precharge of the stabilizer feet on the ground ceases.

Completely close the stabilisers using the relative remote control.



## 9.11. TRACK EXTENSION/RETRACTION

**! Caution**

Carry out the extension and retraction operations of the tracks, with the compulsory recovery of the machine's superstructure (the telescopic boom resting on the column), stabilized (see **9.5**. "Machine stabilization") and lifted at least **210 mm** from the ground.

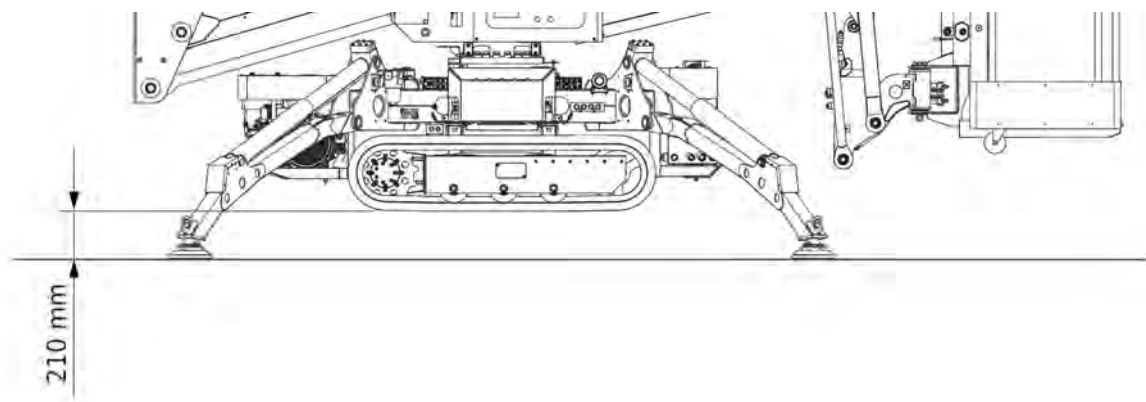



**Note**

The extension/retraction operation is carried out from the remote control on the ground.

- Start the engine (see **9.4.** “start/stop engine”).
- Move the switch (**SA40**) to “ground position”.
- Stabilise the machine (See **9.5.** “Machine stabilisation”).
- Hold down the pushbutton (**SB4T**).
- Operate levers (**JT3**) and (**JT4**) to extend or retract both tracks.



**Note**

It is not possible to open/close the single track.



## 9.12. SHIFTING



**Caution**

Perform movement with the aerial part of the machine in a safe position (the upper and lower boom resting on the column) (The upper and lower boom resting on the column).

In the movement phase, the machine can exceed gradients of up to:

- A** Transversal gradient:
  - Continuous tracks closed **15° (27%)**
  - Continuous tracks open **17° (31%)**
- B** Longitudinal gradient: **17° (31%)**



**Caution**

Shift and stabilise the ground work station with the radio control, with no people in the man basket.

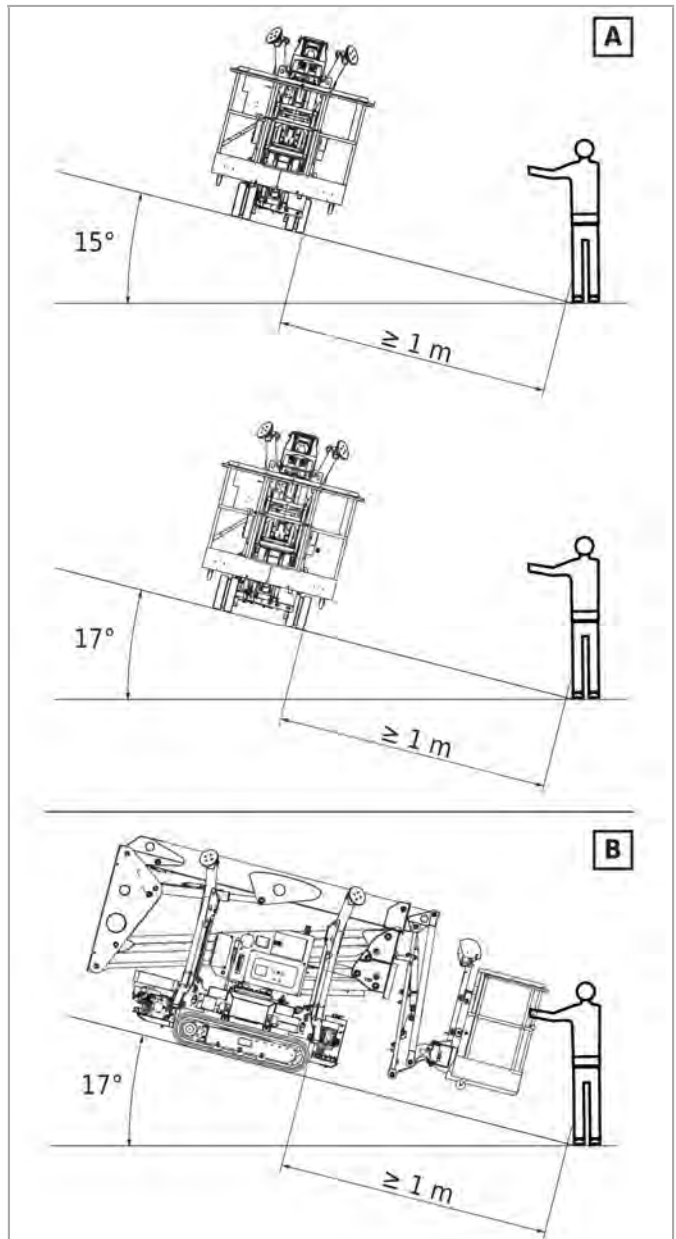



**Caution**

Shifting from the basket is possible under the following circumstances.

- The jib must be completely closed.
  - Maximum allowed tilt of the machine:  
Cross = **10°**  
longitudinal = **10°**
  - Maximum allowed weight in the basket = **136 kg**
- Shifting must be performed with stabilizers in working position close to the ground.**
- Start the engine (see 9.4. “start/stop engine”).
  - Move the switch (**SA40**) to “ground position”.
  - Select the movement speed by activating the selector switch (**SA3T**) into "hare" or tortoise" position.
  - If the conditions of the surrounding area permit it, extend the tracks completely (see 9.11.. "track extension/retraction") in order to have maximum stability in the movement phase.
  - Move at least **1** metre away from the machine.
  - Proceed with closing the stabiliser feet (See 9.5. “Machine stabilisation”).



- Work the (**JT3**) and (**JT4**) panel levers to control forward or backward translation movements.



**Note**

To shift from the basket, remove the remote control from its support.

Each track can be moved individually.

The speed and the direction of movement are proportional to the movement attributed to the pushbutton panel levers.

**9.13. TRANSFORMING THE PUSHBUTTON PANEL FROM RADIO CONTROL TO WIRE CONTROL**

The conversion of the pushbutton panel from radio control to wire control may be caused by:

- Exhausted accumulators.
- The fact that it is impossible to emit radio impulses in the working area (airports, remote control units etc).

### 9.13.1. CONTROL STATION AND GROUND CONTROL

- Press the emergency button **(SBT)** on the pushbutton panel.
- Move the switch **(SA40)** to "OFF".
- Inse the cable supplied in the outlet of the pushbutton panel **(RNT)** and in the outlet,in the column.
- Move the switch **(SA40)** to "ground position".
- Enable the pushbutton panel by releasing the emergency button **((SBT)**.
- Press and hold down the button **(SB2T)** on the pushbutton panel until the green indicator light **(HL1T)** starts to flash.
- Read the message displayed on the pushbutton display and act accordingly.



## 9.14. REPLACING THE PUSHBUTTON PANEL ACCUMULATOR

### Note

When the red indicator light (**HL1T**) starts flashing, this indicates that the accumulator is running down and that there are about **3** minutes of autonomy remaining. Replace the accumulator in this period.

- Press the emergency button (**SBT**) on the pushbutton panel.
- Remove the accumulator from the pushbutton panel.
- Remove the charged accumulator from the (**A**) battery charger.
- Insert the flat accumulator in the battery charger.
- Insert the charged accumulator in its position on the pushbutton panel.
- Check that a control position is enabled from the instrument panel (ground position, basket position).
- Enable the pushbutton panel by turning the emergency button.
- Press and hold down the button (**SB2T**) on the pushbutton panel until the green indicator light (**HL1T**) starts to flash.
- Read the message displayed on the pushbutton display and act accordingly.

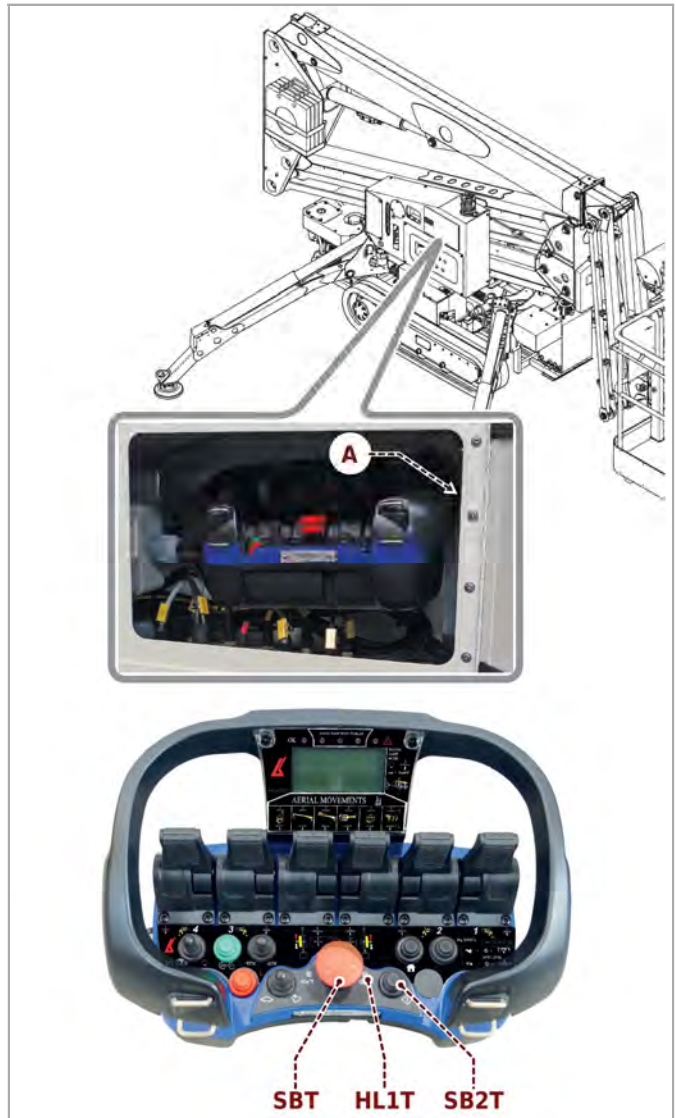

## 9.15. CAGE RELEASE/ATTACHMENT

The machine has rapid cage attachment and release.

If transportation or anything else makes it necessary to unhook the cage from the machine, proceed as follows:

- Up a suitable lifting device for the cage installed on the machine.
- Press the bar **(A)**.
- Remove the cage by making a small rotation movement with successive lifting, in a way to release it from the fork support **(B)**.

To reassemble the basket, it must be positioned in the **(B)** fork and lock it activating the **(A)** lever of the quick coupling/release system.

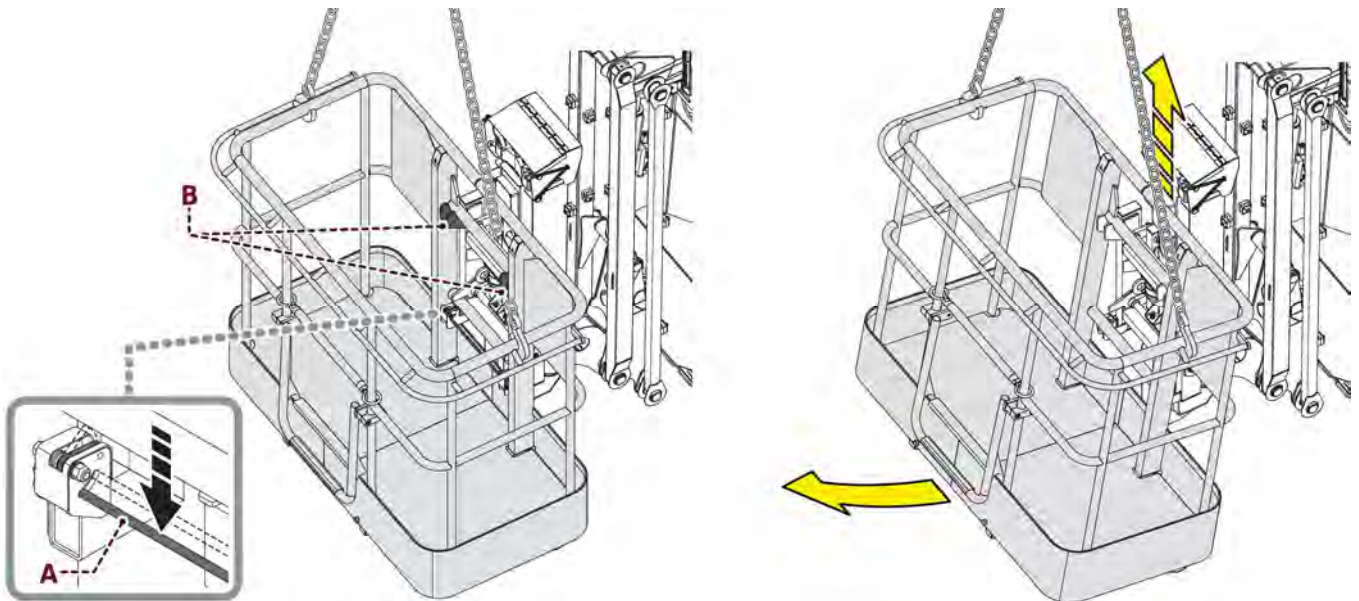

**Danger**

It is strictly prohibited to install any cage other than the original.

**Danger**

Before each time the platform is used, it is mandatory to check that the lever **(A)** is in the correct position.

It is important to know that:

- The machine is tested and certified with the cage installed at the time of delivery.
- The electronic control system is set and calibrated based on the type of cage installed at the time of delivery.

### 9.16. CAGE POSITIONING FOR WORK AND TRANSPORT

The cage may have to be rotated by **70°** to transport the cage.

To rotate it:

- machine retracted;
- Stabilization retracted;
- Turn the switch **(SA40)** to the centre (Ground commands enabled);
- Keeping the **(SA1T)** selector switch in the "backlit" position, operate the **(JT6)** selector switch so that it brings the basket into the position of figure.

To bring the basket back into the work configuration, it is necessary to keep the **(SA1T)** selector switch in the "backlit" position and operate the **(JT6)** selector switch so that it brings the basket into the position of figure;

- Turn the switch **(SA40)** to off.

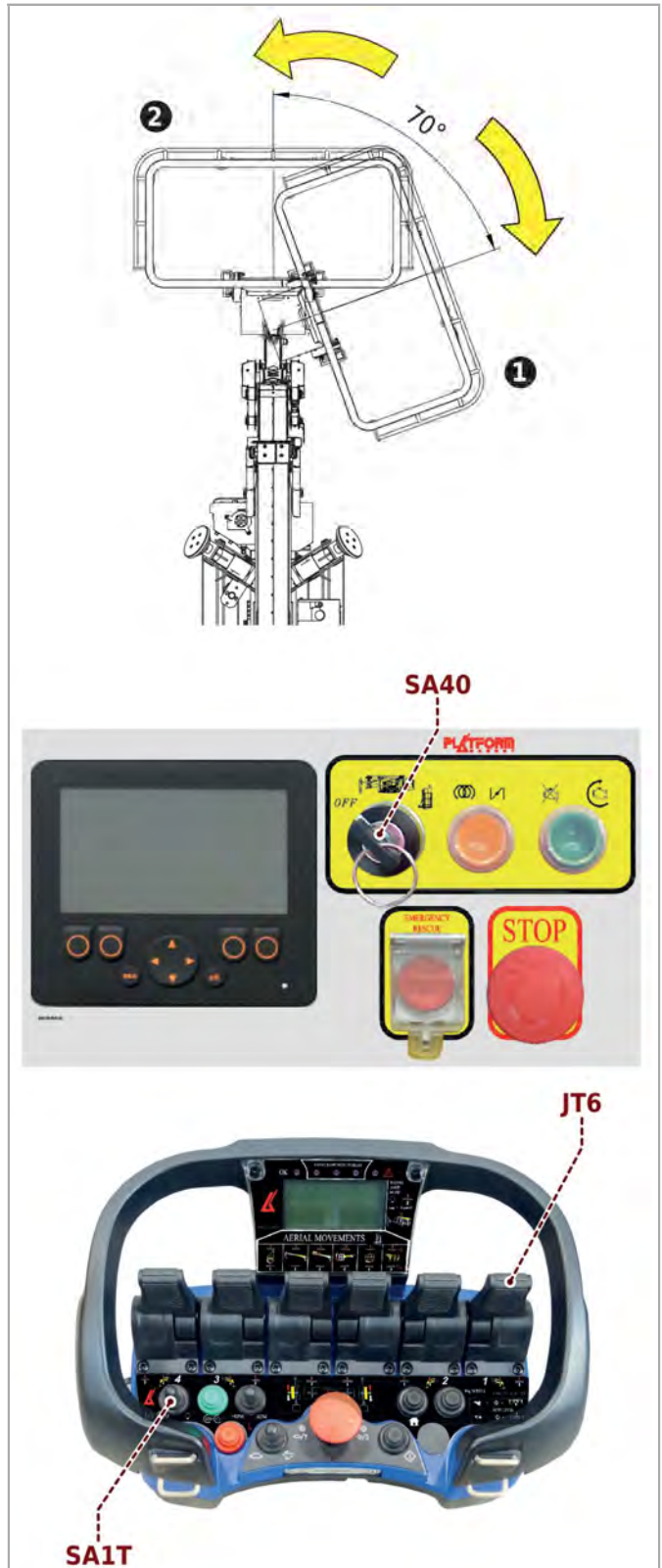

## 9.17. MOVEMENTS IN AN EMERGENCY

Faults and emergency situations require manoeuvres which allow the movement of the aerial part with the aim of bringing the operator in the basket back to the ground and moving the stabilisers for subsequent closure of the machine which can then be moved using suitable means.

The succession of the manoeuvres to make changes in relation to the type of situation or breakdown occurring.

### **Caution**

The functionality of the individual commands is described in section 5 "Commands".

### **Note**

Whenever the machine is not equipped with the **12 V** emergency electric pump (optional), the operator on the ground must act on the manual emergency pump **(A)**.

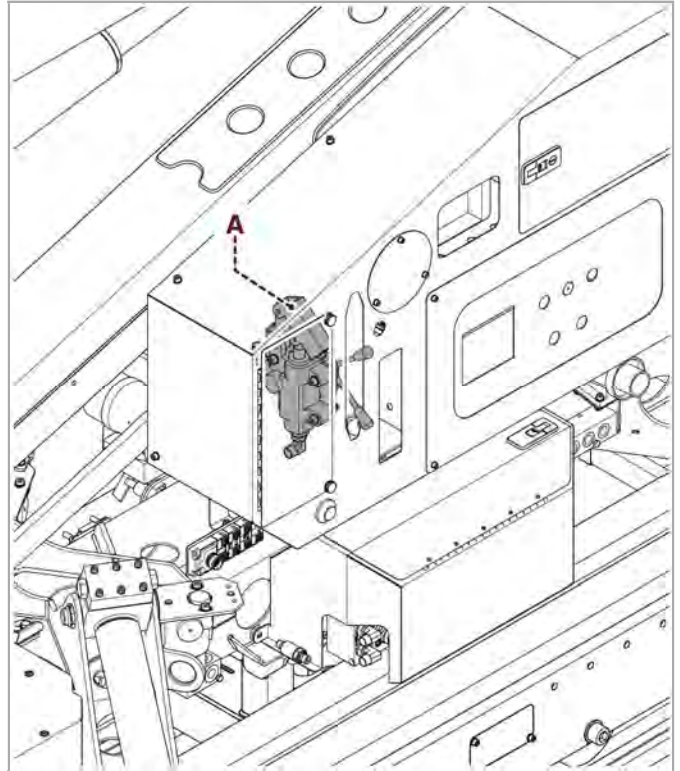

### 9.17.1. CONDITION 1 – SITUATION WHERE THERE IS: FAULT WITH THE PUMPS/MAIN ENGINES WITH ACTIVE ELECTRICAL CONTROL PART

#### **Machine without 12 V emergency electric pump (Optional)**

- Operate **(A)** emergency hand pump and control machine movements with panel in basket.

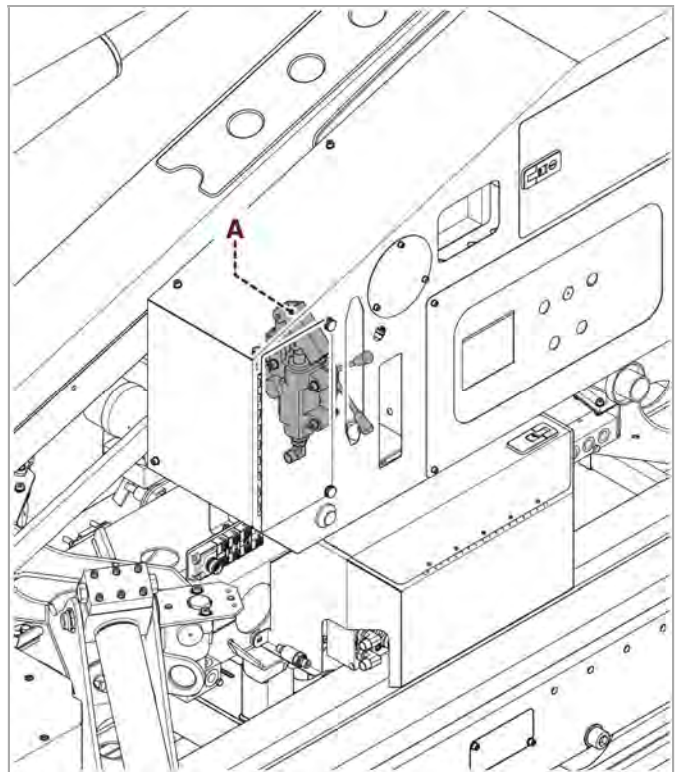

**Machine with 12 V emergency electric pump  
(Optional)**

- Operate emergency hand pump using **(SB4T)** button and control machine movements with panel in basket.



**9.17.2.CONDITION 2 – SITUATION WHERE THERE IS: NO OPERATION OF THE CONTROL SYSTEM FROM THE BASKET OR WHERE THE OPERATOR IS TAKEN ILL IN THE BASKET**

**With the electric plant operating and the motors operating**

Only in an emergency situation:

- Turn the selector **(SA40)** to “ground controls”;
- Open the door **(A)**;
- Press the **(SB51)** button;
- Bring the basket back to the ground using the emergency distributor levers.

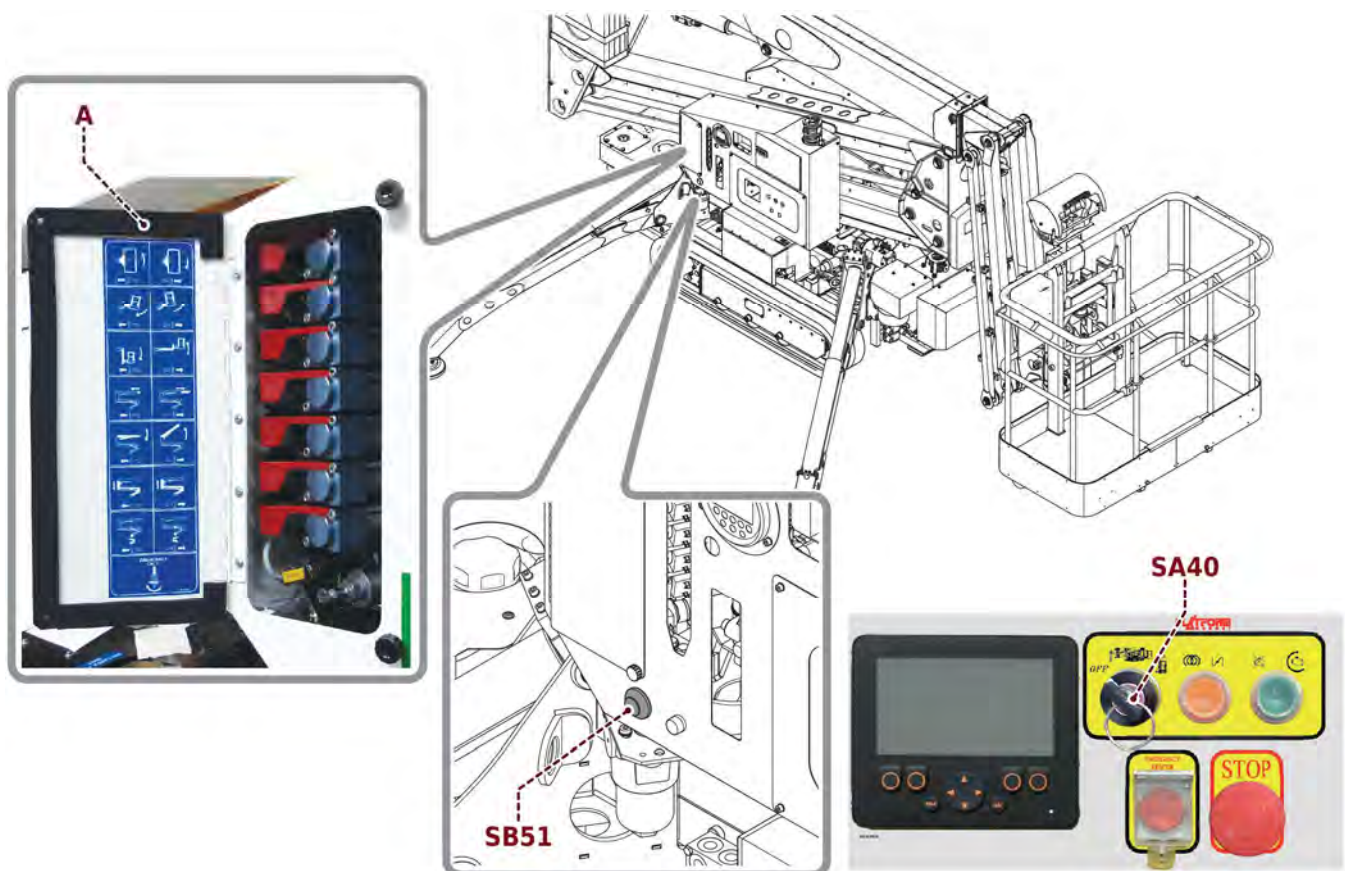

**When there is a malfunction in the electrical system and the motors are working**

The ground operator must carry out the emergency manoeuvre as indicated in the emergency conditions **3**.

**With engines failure and electric plant failure**

The ground operator must carry out the emergency manoeuvre as indicated in the emergency conditions **4**.

**9.17.3.CONDITION 3 – SITUATION WHERE THERE IS: FAULT WITH THE MAIN ELECTRICAL SYSTEM AND IT IS POSSIBLE TO START UP THE PUMPS/MAIN ENGINES**

**! Note**

The emergency electric pump **12V** (if any) and the electric panels have two distinct circuits. Before proceeding with the emergency procedure, control whether the failure also involved the electric circuit of the electric pump.

If the circuit of the electric pump is whole, the movements can be performed by holding down one of the **(SB4T/PSE)** button, which start the electric pump.

If the electric pump does not work, it will be necessary to act on the manual emergency pump **(A)** to perform the movements.

- Turn the selector **(SA40)** to “ground controls”.

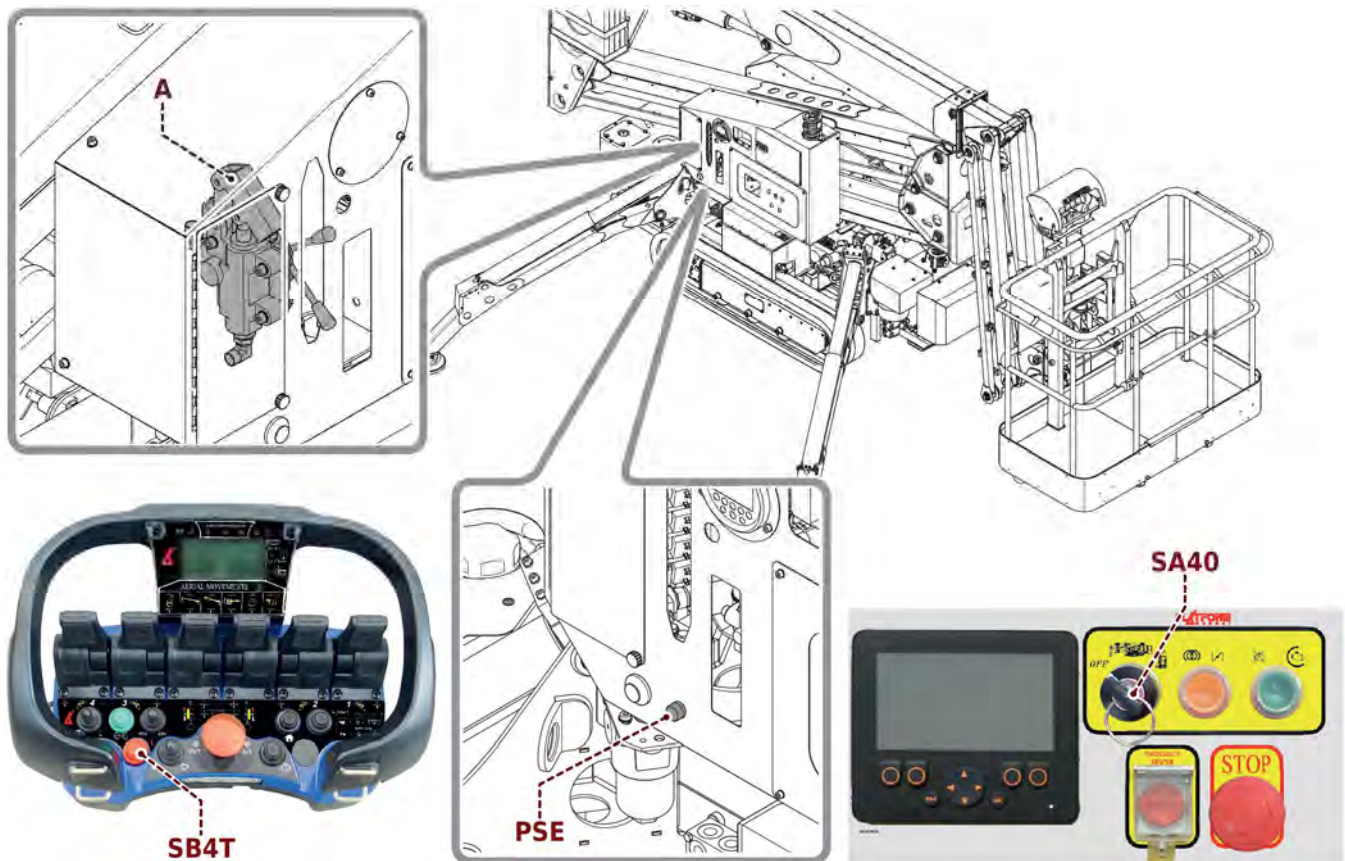

### Aerial part movement

Place the lever **(a)** of the control valve in position **(B)** to enable the superstructure movements.

Open the door **(A)**.

Break the seal, press and turn the pin clockwise until it remains in the lowered positioned and is blocked to bypass the valve **((YV118))**.

Operate the necessary levers to lower the operator to the ground.

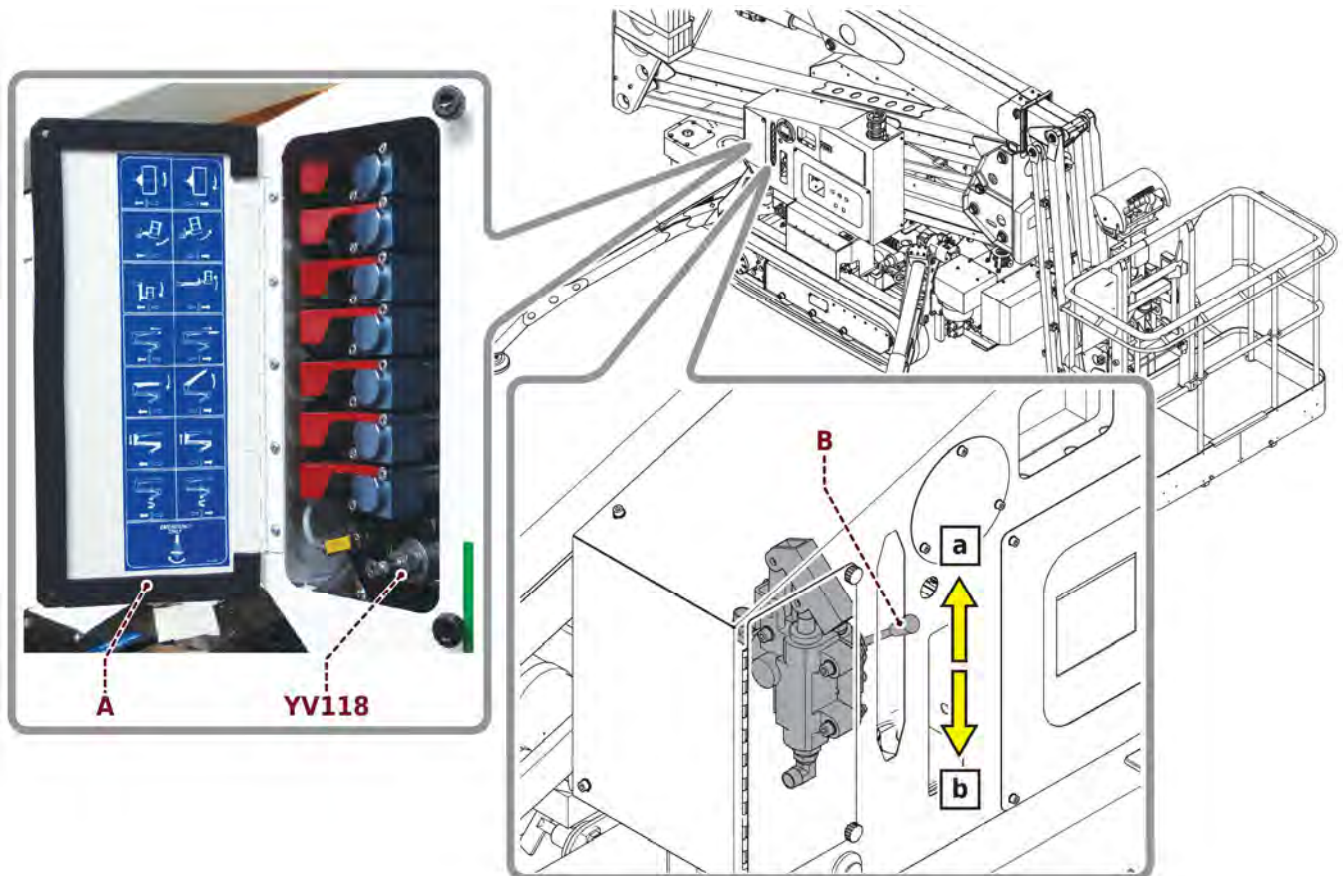

### Caution

In this situation the machine has no outreach limits control so you can only return the extension towards machine centre and then lower the arm to bring the operator in the basket back down to ground safely.

Contact an authorised service centre for any repairs necessary and to replace the seal on the solenoid valve **((YV118))**.

It is forbidden to use the machine with the solenoid valve **(YV118)** without the seal.

- Start the manual emergency pump and at the same time perform the retracting movements of the superstructure from the emergency control valve on the column.
- Once the aerial part has been recovered, the operator in the cage must descend to assist the operator on the ground in the destabilization and movement of the machine.
- Take back the pin of the valve **(YV118)** in its original position (pin raised).
- Continue with the manual pump.

### Movement of ground structure

- Break the seals to bypass the valves **YV125 - YV126 - YV127**.
- Press and turn the pin clockwise to keep it in a lowered, blocked position.
- To move the stabilisers **1 - 2 - 3 - 4** and the left continuous track put the lever **(a)** of the control valve in position **(B)** (Valves **YV125 - YV126**).
- To open/close the continuous tracks and move the right continuous track, put the lever **(b)** of the control valve in position **(B)** (Valve **YV127**).

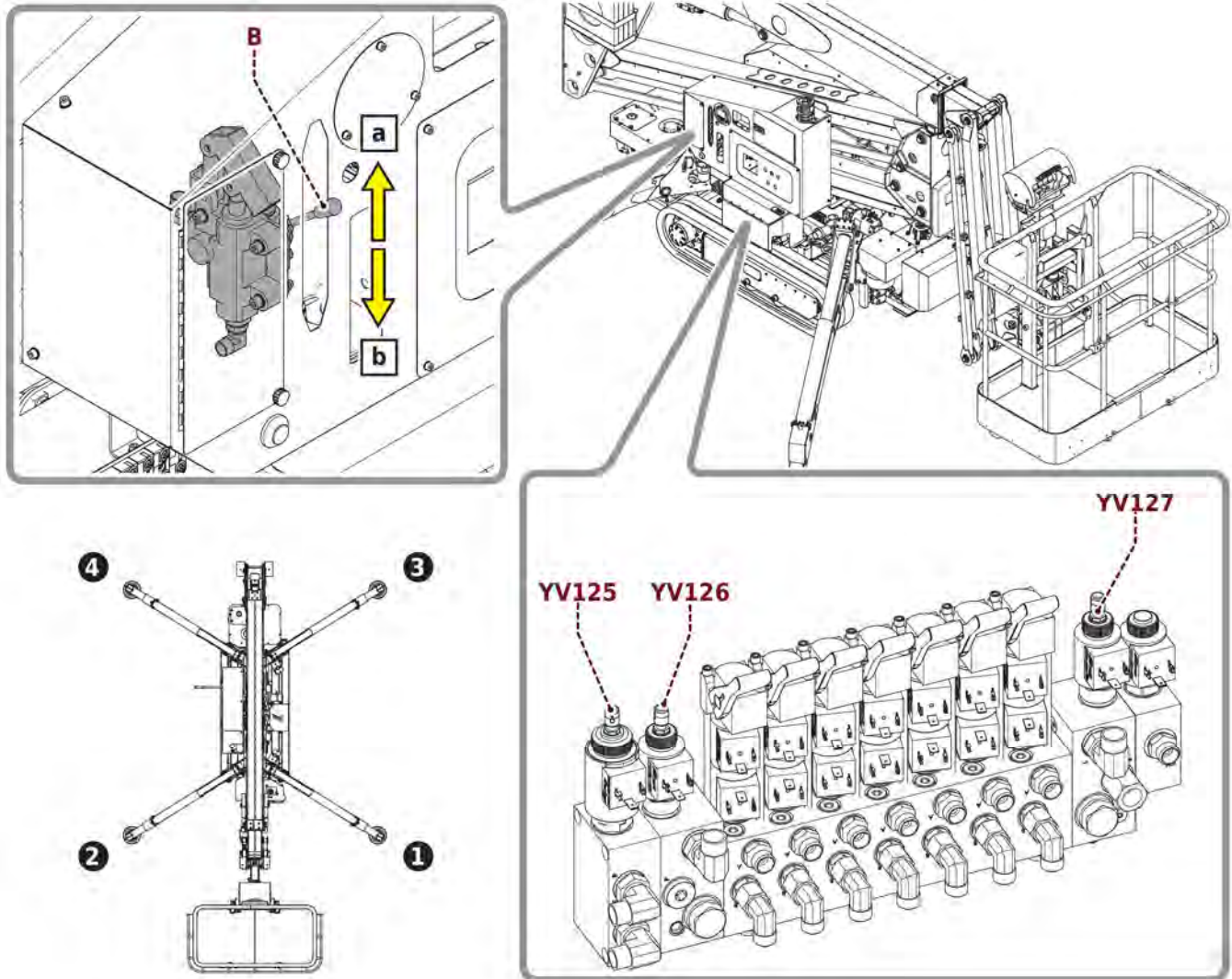

#### Caution

Before reusing the machine, it is compulsory to address to an authorised assistance centre for any repairs required, to recover the safety components and to place the seals on the tampered solenoid valves.

It is forbidden to use the machine with the solenoid valves without the relating seals.

#### 9.17.4. CONDITION 4 – SITUATION WHERE THERE IS: FAULT WITH THE MAIN ELECTRICAL SYSTEM AND IT IS IMPOSSIBLE TO START UP THE PUMPS/MAIN ENGINES

**!** Note

The emergency electric pump **12V** (if any) and the electric panels have two distinct circuits.  
Before proceeding with the emergency procedure, control whether the failure also involved the electric circuit of the electric pump.  
If the electric pump circuit is intact, the movements can be carried out by pressing the button **(SB51)**.

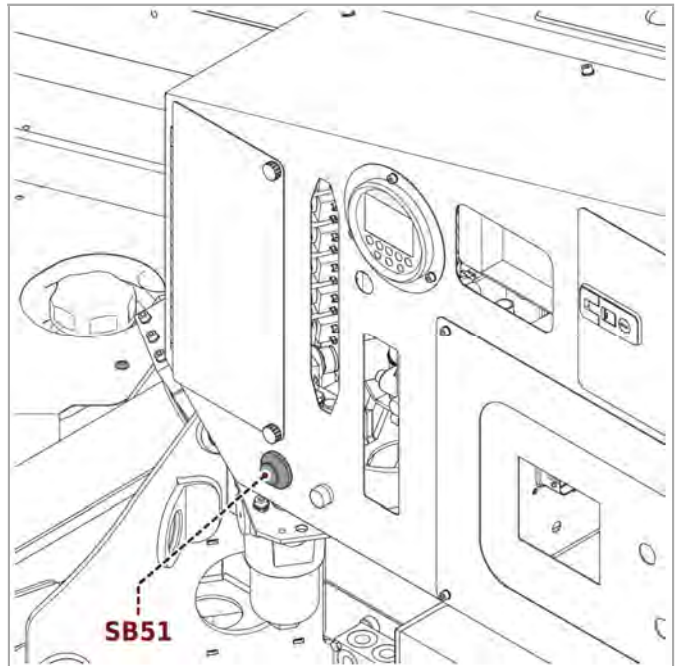

**Aerial part movement**

- Open the door **(C)**;
- Break the seal, press and turn the pin clockwise until it remains in the lowered positioned and is blocked to bypass the valve **((YV118))**;
- Command the return movements from the distributor using the hand pump **(A)** or, if present and operational, the emergency electric pump **((SB51))**;

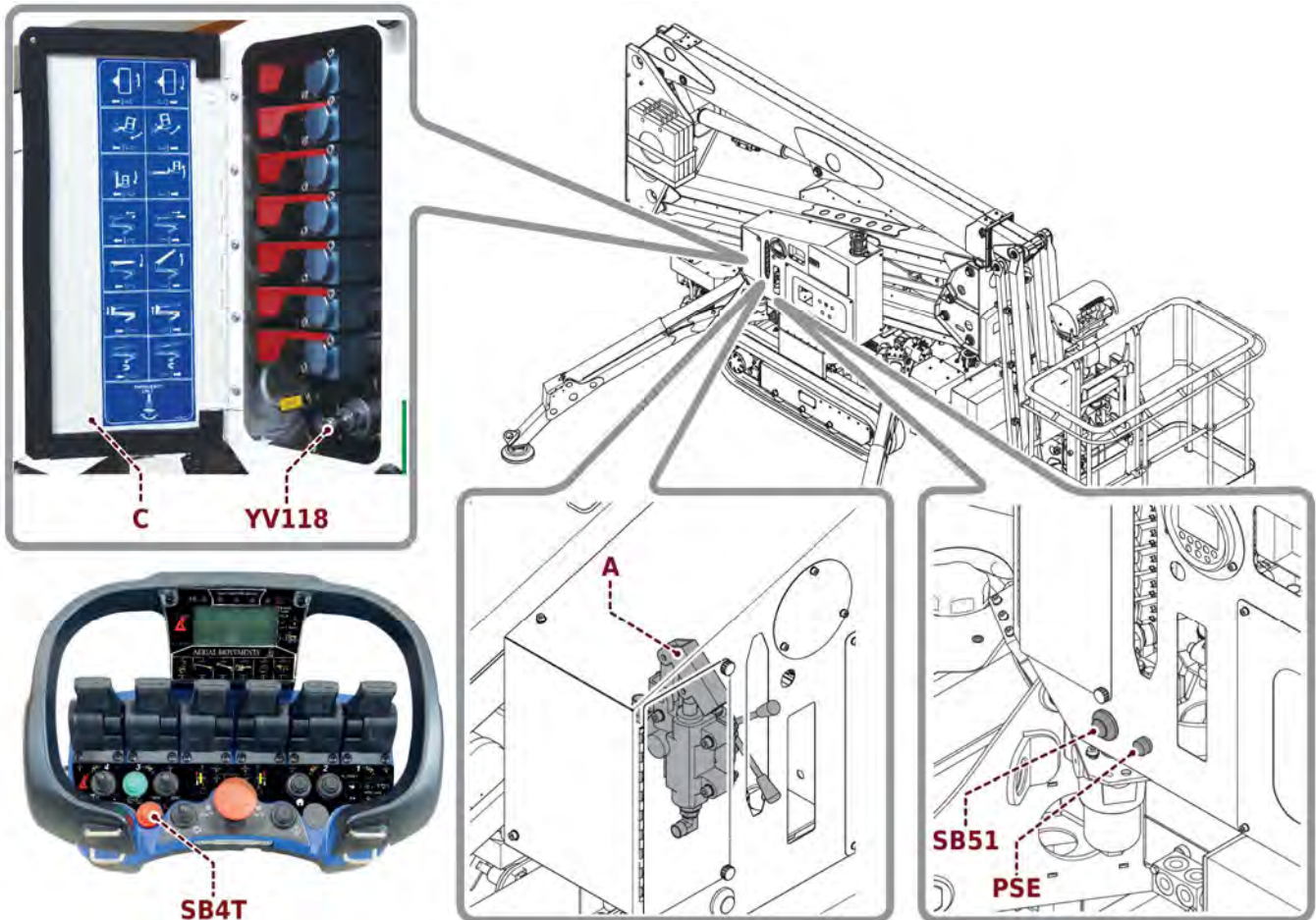

- Perform the sequence of movements listed below to bring the operator back to the ground:
  - 1** Extension retraction;
  - 2** Arm lifting or lowering and pantograph lowering;
  - 3** close jib.
- Command the return movements from the distributor using the hand pump **(A)** or, if present and operational, the emergency electric pump **(12V (PSE/SB4T))**;



**Caution**

In this situation the machine has no outreach limits control so you can only return the extension towards machine centre and then lower the arm to bring the operator in the basket back down to ground safely.

Contact an authorised service centre for any repairs necessary and to replace the seal on the solenoid valve **((YV118))**.

It is forbidden to use the machine with the solenoid valve **(YV118)** without the seal.

- Once the aerial part has been recovered, the operator in the cage must descend to assist the operator on the ground in the destabilization and movement of the machine.
- Take back the pin of the valve in its original position (pin raised).

- Continue with the manual pump.

**Movement of ground structure**

- Break the seals to bypass the valves **YV125 - YV126 - YV127**.
- Press and turn the pin clockwise to keep it in a lowered, blocked position.
- To move the stabilisers **1 - 2 - 3 - 4** and the left continuous track put the lever **(a)** of the control valve in position **(B)** (Valves **YV125 - YV126**).
- To open/close the continuous tracks and move the right continuous track, put the lever **(b)** of the control valve in position **(B)** (Valve **YV127**).

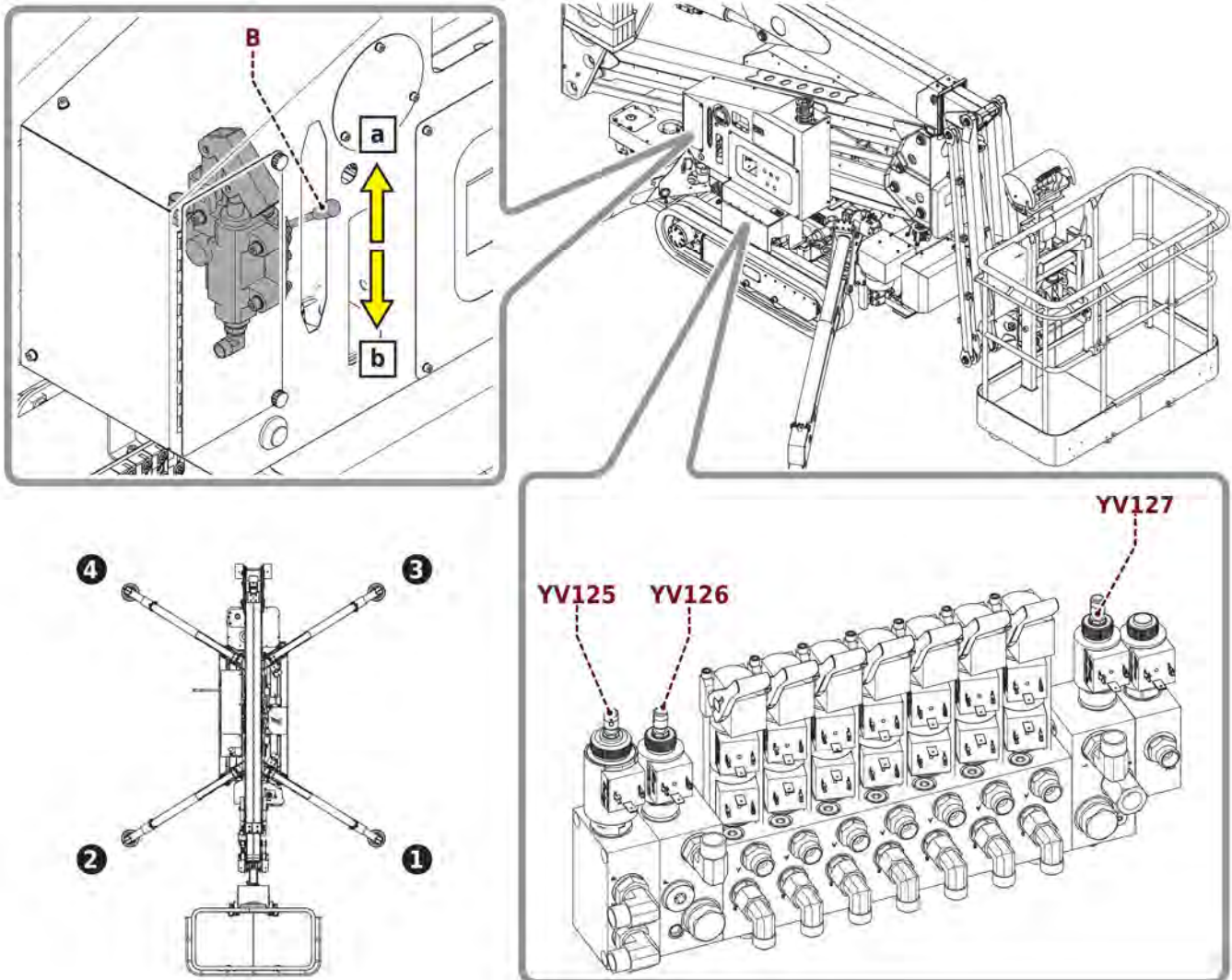

**Caution**

Before reusing the machine, it is compulsory to address to an authorised assistance centre for any repairs required, to recover the safety components and to place the seals on the tampered solenoid valves.

It is forbidden to use the machine with the solenoid vales without the relating seals.

## 10. TROUBLES - CAUSES - REMEDIES

### 10.1. FOREWORD



#### Danger

The operations described in the various headings must be carried out exclusively with the machine stopped and disconnected from the power sources (electrical and pneumatic).



#### Caution

The following cases present possible breakdown situations and, for each one, there is a list of control sequences to be followed to remove motives which could have caused machine damage.

#### 10.1.1. TECHNICAL ASSISTANCE

Consult your **PLATFORM BASKET S.r.l.** Dealer, or contact **PLATFORM BASKET S.r.l.** Technical Service directly, specifying the information found on the machine identification dataplate:

- Type of machine.
- Serial number.

Also supply all the relevant information concerning the problem detected.

### 10.2. MAINS DEFECTS



#### Caution

The operations reported in this chapter are to be done exclusively by the authorised shops.

#### The motor does not start even though the starter works correctly

<i>Causes</i>	<i>Remedy</i>
No fuel Insufficient oil pressure	Check the amount of oil in the tank. Check the amount of fuel. See the enclosed user instructions for the endothermic engine.

#### The hydraulic pump is very noisy

<i>Causes</i>	<i>Remedy</i>
Too low oil level.	Check oil level.
The pump sucks too much air.	Fasten the line fittings.
Too thick oil.	Replace oil.
Wear kinematisms.	Overhaul the pump.

### Cylinders loosing oil, decreasing capacity with pump not working, power decreasing

<i>Causes</i>	<i>Remedy</i>
Wear tight-seals.	Replace seals, checking wear not coming from linings on the telescopic rod or on the cylinder.
Leakages on lock valves.	Overhaul valves check valves cleanliness and setting.
Control valve with internal leakages.	Overhaul control valve, check valves cleanliness and setting.

### The machine moves with irregular motions of booms, jerkily and slowly

<i>Causes</i>	<i>Remedy</i>
Presence of air in the hydraulic circuit.	Sometimes make stopper- up going- down going- movements untill the complete discharge of air.
Telescopic boom wear pads.	Replace worn down wear pads.

### The machine doesn't complete the movements, jerkily steerings

<i>Causes</i>	<i>Remedy</i>
Oil not enough.	Reset oil level.
Air suction.	Fasten fittings.
Valves wrong setting.	Register valves.
Breakdown pump.	Check the pump.

### Metal particibles founded in the oil filters

<i>Causes</i>	<i>Remedy</i>
Parts of the oleo dynamic system are damaged.	Find the breakdown parts, replace them.

### Movements prevented

<i>Causes</i>	<i>Remedy</i>
Machine overloaded.	Eliminate the load from the cage.
Load diagram reach limit reached.	Let the extensions come in.
Impurities presence in solenoid valve spool.	Disassemble the valve and clean the internal parts.
The coil of the solenoid valve does not work.	Change the coil.

<b>Light oil filaments in cylinders seals</b>	
<i>Causes</i>	<i>Remedy</i>
After long inactive periods.	After a certain number of working hours, you will not have any filaments.
<b>Load holding valves whistle too much</b>	
<i>Causes</i>	<i>Remedy</i>
Dirty load holding valve.	Disassemble and clean the valve.
Ruined load holding valve.	Replace valve.
Too low valve setting.	Check valve setting.
Too high control valve setting.	check control valve setting.
Enervate valve spring.	Replace valve.
<b>Oil loosing from the cylinders tops</b>	
<i>Causes</i>	<i>Remedy</i>
Ruined cylinder seals.	Replace cylinder seals.
Too slow end cap on rod.	Unfasten end cap, clean and reassemble with loctite.
Cylinder with swelled outer casing.	Replace cylinder.
Rust under seals setting place.	Replace only the ruined component.
<b>Radio control is disengaged and goes into emergency mode</b>	
<i>Causes</i>	<i>Remedy</i>
Presence of high voltage lines near the machine.	Connect the remote control to the cable supplied.
Discharged remote control battery.	Replace remote control battery.
<b>The machine seeps much oil of connectors and of seals generally</b>	
<i>Causes</i>	<i>Remedy</i>
General seal ruined.	Replace gaskets/seals.
Too slow fittings.	Fasten fittings or check however their sealing.
Too warm oil.	Add oil in tank.
Few oil in tank.	Add oil in tank. Replace with a thicker oil.
Too old or ruined system rubbers.	Replace rubber pipes.

### Control valve lever which stops or which comes back hardly

<i>Causes</i>	<i>Remedy</i>
Dirt into the spool.	Disassemble and clean spool even with paste erasing micro-impurities. Clean with air the control valve element.
Ruined spool.	Replace spool.
Return spring too weak or broken.	Replace springs.
CE cylinders, which do not discharge pressure.	Check discharge pressure from the CE cylinders.
Radio module stop or always in voltage.	Replace battery.
Too back pressure in control valve discharge.	Verify discharge pressure.
Sealing OR which produce too friction.	replace OR seals.
Assembled control valve and tie rods too strongly fastened.	Check with a dynamometric key the control valve tightening tie rods.

### Machine with electric pump which does not move

<i>Causes</i>	<i>Remedy</i>
Electric pump does not receive power.	Check electric connections.
Burnt electric pump.	Check electric pump. Replace electric pump.
Wrong electric connection.	Check electric connections.
Emergency pushbutton pressed.	Reset the emergency button.
Oil lack.	Replace or add oil.
Pump leaking oil.	Replace pump or oil cover.
Burnt fuse.	Replace fuse and discover why it has blown.

### Stabiliser cylinders come out unable to keep pressure

<i>Causes</i>	<i>Remedy</i>
Dirty or damaged load holding valve.	Check valve.
Damaged cylinder gaskets.	Replace gaskets/seals.
Cylinder with swelled outer casing.	Check internal cylinder sealings. Replace cylinder.
Centre distributor spool open.	Check control valve spool.

## 11. MAINTENANCE

### 11.1. FOREWORD

#### **Caution**

Before doing any maintenance work and especially maintenance and/or repairs to the electrical system or if it is necessary to do welding, completely disconnect the batteries of the machine via the battery-disconnector master switch.

The terms periodic and routine maintenance refer to interventions which must be performed regularly throughout the whole of the machine's working life at a set frequency.

Inspection and careful maintenance allow the machine to work continually and with maximum efficiency. The following is a list of operations to be performed on the machine.

Remember also that the prompt replacement of a worn part avoids further damage and reduces the time that the machine is inoperative.

Other maintenance work not covered by this section is to be considered as special maintenance and is not part of the duty assigned to the operators who use the machine. This kind of work must be done by a specialized workshop.

#### **Danger**

All maintenance work must be done with the machine inoperative, in other words with the motor switched off, the electrical voltage to the panels cut off and the machine in the rest position.

#### **Caution**

A few pages have been added to this manual so that the operator assigned to maintenance can keep notes of the maintenance work done and the number of hours the machine has worked, in the latter case making use of the hour-meter.



During operating and maintenance do not dispose of pollutants (oils, greases, etc.) into the environment, and dispose of the various products separately in compliance with current laws in this regard.

The Waste of Electrical and Electronic Equipment may contain hazardous substances with potentially harmful effects on the environment and the health of people.

It is therefore recommended that disposal is carried out in a correct manner.

In terms of the WEEE (Electrical and Electronic Equipment Waste) directive, when scrapping, the user is to separate the electrical and electronic components and dispose of them via authorised collection centres, or they must hand them over, still installed, to the seller when making a new purchase.

## 11.2. MAINTENANCE WORK SAFETY

- Use tools and equipment that are suitable for the purpose.
- Only qualified personnel assigned to the maintenance operations must be present in the maintenance area/room.
- Never leave metal tools such as spanners or the like on the machine as these could cause irreparable damage.
- Replace worn parts with identical, original spare parts.
- It is forbidden to make modifications or replacements using components which are unsuitable or not authorised by the manufacturer.
- Before doing any intervention on pressure lines, it is necessary to depressurise them by using the control levers.
- At the end of maintenances or reparations and before activating the machine again, check that you have not some tools, rags or some other material near the moving parts.



### Caution

Wear specific anti-piercing gloves when performing maintenance work.

Maintenance interventions must be carried out at least at the recommended intervals, although the precise frequency depends on the conditions of use of the machine.



During maintenance, repair, cleaning, or adjustment indicate the machine stoppage in a clearly visible manner with a sign placed on the control panel reading "WORK IN PROGRESS".

WORK IN PROGRESS; OPERATION PROHIBITED



### Caution

Replace worn parts with identical, original spare parts.

It is forbidden to make modifications or replacements using components which are unsuitable or not authorised by the manufacturer.



### Caution

Before starting the machine up again, correctly re-mount and tighten all the parts which have been removed (in particular fixed and moving covers and safety components).



### Danger

Read the "Safety" section of this manual in its entirety before starting work.

#### Key to symbols used in the chapter



Inject grease through the grease nipple



Cleaning with vacuum cleaner



Inject grease through the grease nipple



Grease by means of a grease gun

### 11.3. ROUTINE MAINTENANCE FREQUENCY TABLE (CLEANING)

	Assiduity of maintenance							
	*	h 8	h 50	h 100	h 250	h 500	h 900	h 1800
Cleaning machine			X					
Cleaning the dataplates and indicator lights	X							

\* If necessary.



#### Caution

For the maintenance operations on commercial components, consult the use and maintenance manuals of the specific component.

### 11.4. ROUTINE MAINTENANCE FREQUENCY TABLE (LUBRICATION)

	Assiduity of maintenance							
	*	h 8	h 50	h 100	h 250	h 500	h 900	h 1800
Greasing joints <sup>(1)</sup>					X			
Hydraulic oil level check <sup>(1)</sup>			X					
Extension greasing			X					
Replace the hydraulic oil						X		
Stabiliser greasing				X				
Turret rotation unit greasing					X			
Engine oil replacement <sup>(2) (4)</sup>	X		X <sup>3</sup>					
Motor oil filter replacement <sup>(2)</sup>					X			

\* If necessary.

<sup>(1)</sup> First **10** hours of operation.

<sup>(2)</sup> Must only be performed by a specialised workshop.

<sup>3</sup> First **50** hours of operation.

<sup>(4)</sup> use a suitable lubricant oil depending on the fuel used (with high or low sulphur content). consult the engine manufacturer's use and maintenance manual.



#### Caution

For the maintenance operations on commercial components, consult the use and maintenance manuals of the specific component.

### 11.5. ROUTINE MAINTENANCE FREQUENCY TABLE (MECHANICAL MAINTENANCE)

	Assiduity of maintenance							
	*	h 8	h 50	h 100	h 250	h 500	h 900	h 1800
Replace pressure filter cartridges <sup>(1)</sup>					X			
Replace the discharge filter cartridge					X			
Checking and tensioning the tracks						X		
Check wear and tensioning of the telescopic components output chains						X		
Replacing telescopic components output chains <sup>(2)</sup>	X							
Control of wear and registering shoes <sup>(2)</sup>			X					
Checking the battery charging level			X					
Check the combustion engine starter battery						X		
Check tightening <sup>(1)</sup>					X			
Control turret rotation play <sup>(2)</sup>							X	
General structure check <sup>(2)</sup>					X			

\* If necessary.

<sup>(1)</sup> First **10** hours of operation.

<sup>(2)</sup> Must only be performed by a specialised workshop.



**Caution**

For the maintenance operations on commercial components, consult the use and maintenance manuals of the specific component.

### 11.6. ROUTINE MAINTENANCE FREQUENCY TABLE (ELECTRICAL MAINTENANCE)

	Assiduity of maintenance							
	*	h 8	h 50	h 100	h 250	h 500	h 900	h 1800
Check limitswitch					X			
Check emergency buttons			X					
Fuse replacement	X							

\* If necessary.



**Caution**

For the maintenance operations on commercial components, consult the use and maintenance manuals of the specific component.

### 11.7. ROUTINE MAINTENANCE FREQUENCY TABLE (FUNCTIONING TESTS) <sup>(1)</sup>

	Assiduity of maintenance							
	*	h 8	h 50	h 100	h 250	h 500	h 900	h 1800
Verifying the correct operation of the machine while carrying the 100% of the rated load at normal speeds.								X
Verify the correct operation of all safety devices.								X
Verifying the machine's correct working speed								X

\* If necessary.

<sup>(1)</sup> The frequency, the extension of periodic examinations and tests depend on the regulations in the machine's Country of use.



**Caution**

For the maintenance operations on commercial components, consult the use and maintenance manuals of the specific component.

## 11.8. CLEANING

After every trip and every intervention, clean carefully the equipment (joints, pins, sliding pads).

For crane versions with top controls, keep possible handles and footboards clean from oils, greases and dirtiness, to prevent any sliding and falling.

When you wash the machine, protect properly its components and electric connections, because using direct and under pressure jets on equipments and electric connections could cause damages.

For avoiding the early usury of junction clean dust, impurities and dirt from jacks shaft using no abrasive material or cleansings.



### Caution

This procedure must be performed with care to avoid scratching or scoring the rods.

- Clean impurities and dirt on controls.
  - The carpentry protected by paint has to be cleaned with water and non-corrosive cleansers.
- We suggest you to dry carefully after every washing (by blowing compressed air).



### Danger

It is strictly forbidden to address water jets near electric components (boards, electric valves, push button, etc.) and oil plugs.

### 11.8.1. CLEANING THE DATAPLATES AND INDICATOR LIGHTS

Whenever it becomes necessary, clean the control indications, the indicator lights, the plates and, above all, the safety pictograms.

All dataplates and decals on the machine or on parts of the machine must be clearly legible.

If deterioration is found, request a replacement by contacting the manufacturer's spare parts service directly.

## 11.9. GREASING

Using the pump lubricator, put lubricating grease through the grease nipples on all the articulation points until lubricant leaks out, thereby replacing the used grease (see **11.9.1.** "Greasing points layout").

Start up the machine for the time strictly necessary to perform a few movements with the greased joints.

### 11.9.1. GREASING POINTS DIAGRAM

The illustration below shows the grease nipples.  
Inject grease into all the grease nipples.

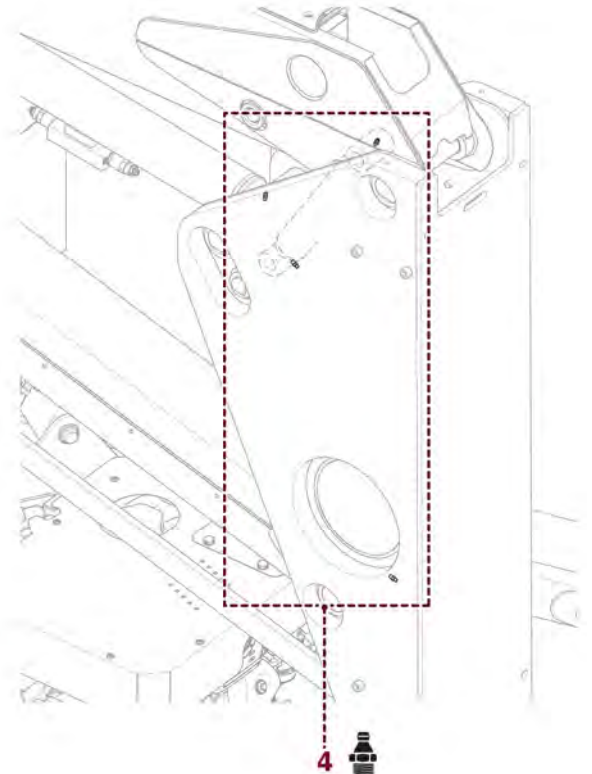
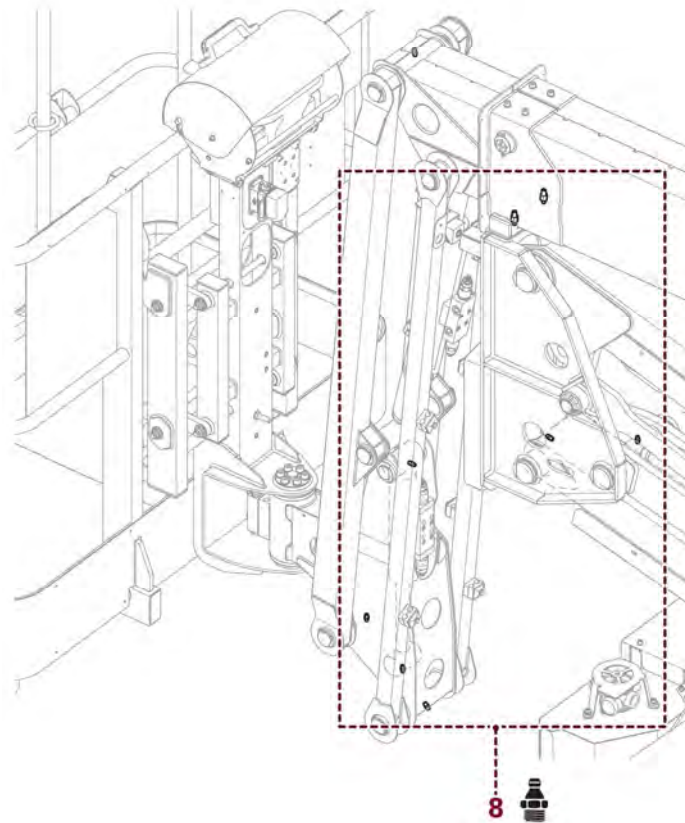
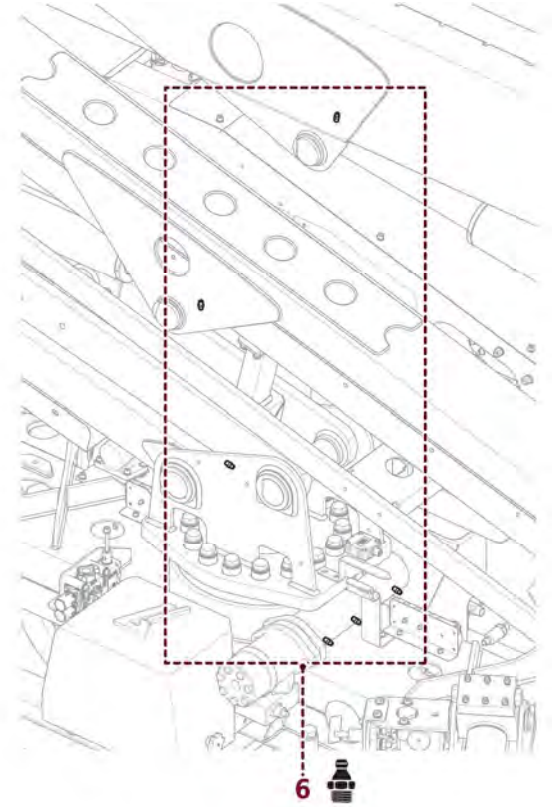
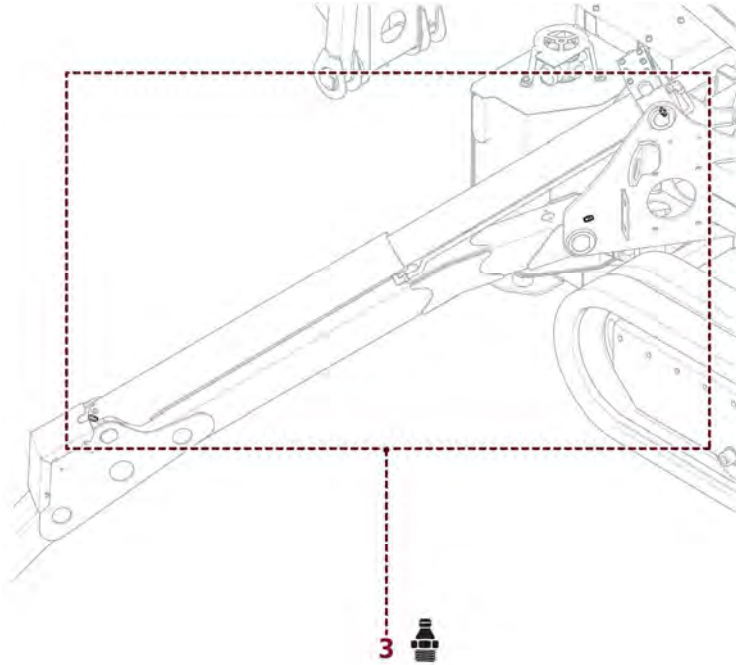

## 11.10. LUBRICATION

The smooth surfaces and the gears should first be cleaned of spent grease with a spatula and then lubricated with fresh grease using a brush.

Always remove excess grease.



### Caution

Damaged or clogged lubricators must always be replaced.



### Caution

Use lubricant grease having the same characteristics as that shown in the specific table in this section.

## 11.11. CHECKING THE LEVEL AND REPLACING THE HYDRAULIC OIL

### 11.11.1. CHECK

Check the right level directly on the tank.

The tank holds the correct amount of oil if the level is visible on indicator **(A)**.

The oil level should be checked when the machine is completely closed and the stabilisers fully raised.

The level should be kept aligned as close as possible with the max ref.

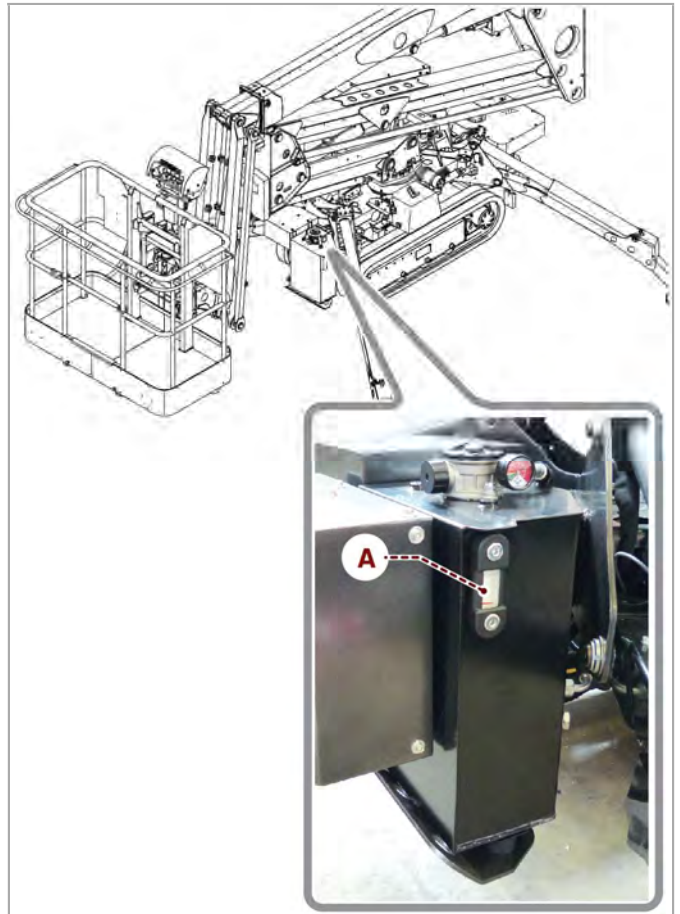

### 11.11.2. CHANGE



**Danger**

Oil at high temperature.

Risk of burns.

Before realising the interventions, wait some minutes with the machine stopped and the motor off.

- Check the oil level in the tank using the gauge **(A)**.
- Prepare a vessel able to contain the quantity of oil in the tank and place it under the tank.
- Unscrew the drain plug **(B)**.
- waiting for the fully outgoing of oil, clean and assemnle the cap **(B)** again.
- Open the cap **(C)** e put oil into it, reaching the right level.
- Close the cap **(C)** again.



**Caution**

Use the hydraulic oil with the same characteristics.



**Caution**

Do not introduce oil directly in the tank without having filtered it previously.



**Caution**

Spent oil must be disposed of in compliance with local legislation.



**Caution**

It has to be delivered to a collecting and sale body for used oils.

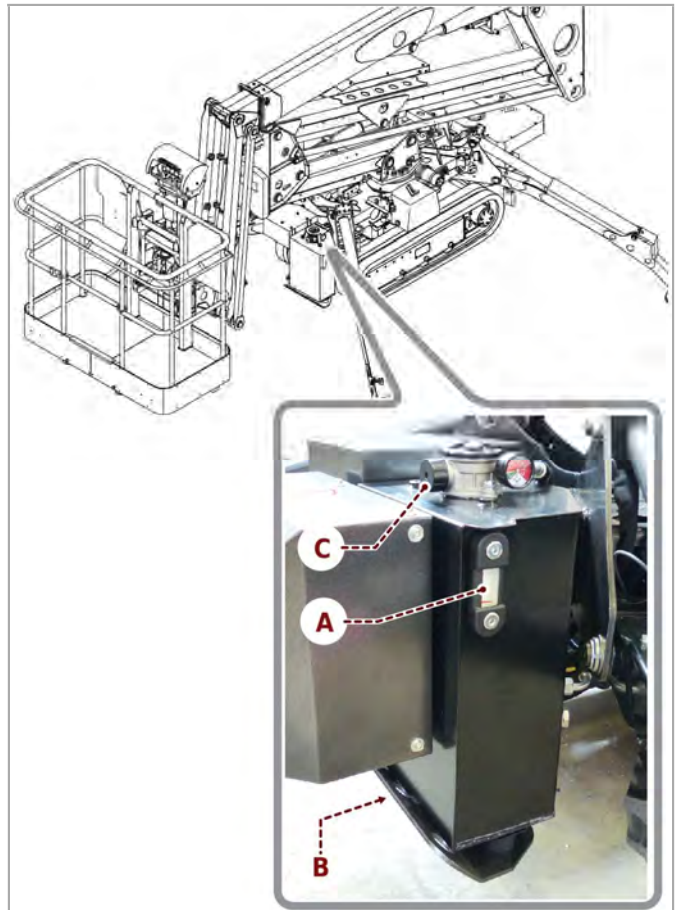

## 11.12. LUBRICANTS TABLE



### Caution

All maintenance work must be done with the motor switched off and the machine in the rest position.



### Caution

Do not add oil different to what the manufacturer advises.

Key



**A** Grease



**B** Grease



**C** Hydraulic oil

	<b>A</b>	<b>B</b>	<b>C</b>	
<b>TOTAL</b>	MULTIS EP 2	MULTIS EP 2	AZOLLA ZS 46 ZS 68 (*)	
<b>MOBIL</b>	MOBIL GREASE MP	MOBIL GREASE MP	DTE 25	
<b>ESSO</b>	BEACON EP2	BEACON EP2	NUTO H 46 H 68(*)	INVAROL EP 46
<b>AGIP</b>	GR MU EP 2	GR MU EP 2	OSO 46 68(*)	ARNICA 46
<b>IP</b>	ATHESIA EP2	ATHESIA EP2	HYDRUS 46 68(*)	
<b>BP</b>	ENERGREASE LR MP	ENERGREASE LR MP	HENERGOL HL 80	

(\*) For hot climates.

### 11.13. REPLACE PRESSURE FILTER CARTRIDGES

The hydraulic fi lter **(a)** is provided with an indicator **(b)** that shows when the fi lter is blocked.

Move the machine into the rest configuration.



#### Danger

Turn off the machine by cutting off the electrical power to the control panels, also making sure that the hydraulic oil is not at a temperature of **40°C**.

With a special strap wrench unscrew and replace the filter cartridges with new ones having the same filtration grade (**20µ**).



#### Caution

Before putting back the filter, grease the seal.

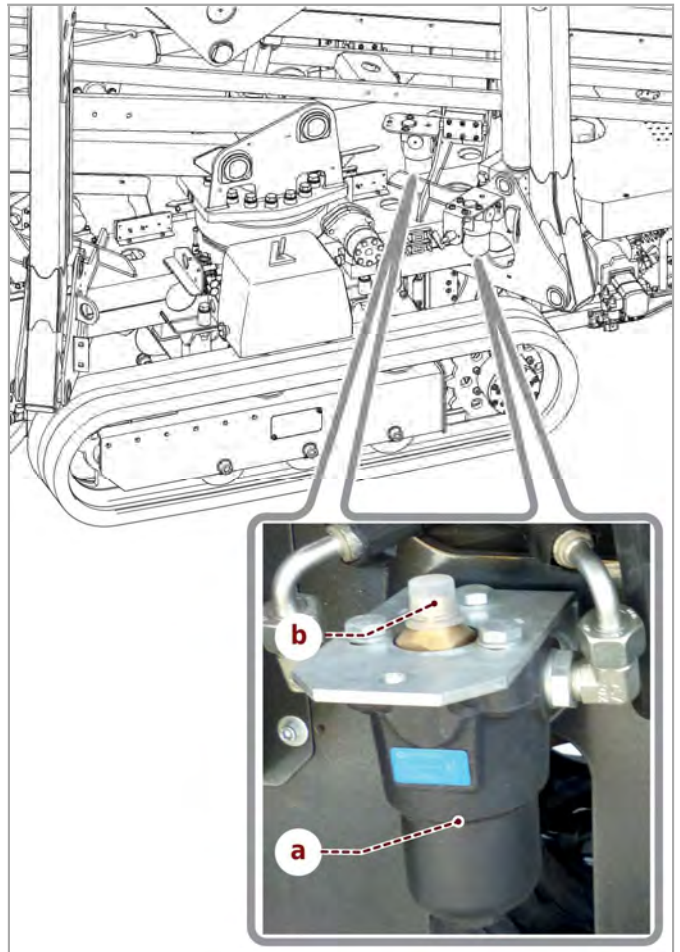

### 11.13.1. CLEANLINESS/REPLACEMENT OF THE RETURN FILTER

During the operations of replacement and cleanliness of the filter, the pump must be disconnected.

Clean the area near the filter before removing it.

When established and, however, when the optical indicator **(A)** signals the clogging, the filtering cartridge must be replaced.



**Caution**

Oil at high temperature.  
Risk of burns.

- Unscrew the cover **(B)** of the filter.
- Extract the filter and clean or replace it with one with the same filtering capacity.



**Caution**

Lubricate and check the position of the seal between the cover and the filter.

**Cartridge cleaning:**

It is better to change it, otherwise it is possible to clean it blowing compressed air in it. Check that at the end of the operation the cartridge doesn't have impurities left on the filtering web.

In case you find damages or breaks, replace it.

**Remounting:**

Assemble the componenets again, checking that possible trimmings are not damaged, on the contrary change them.

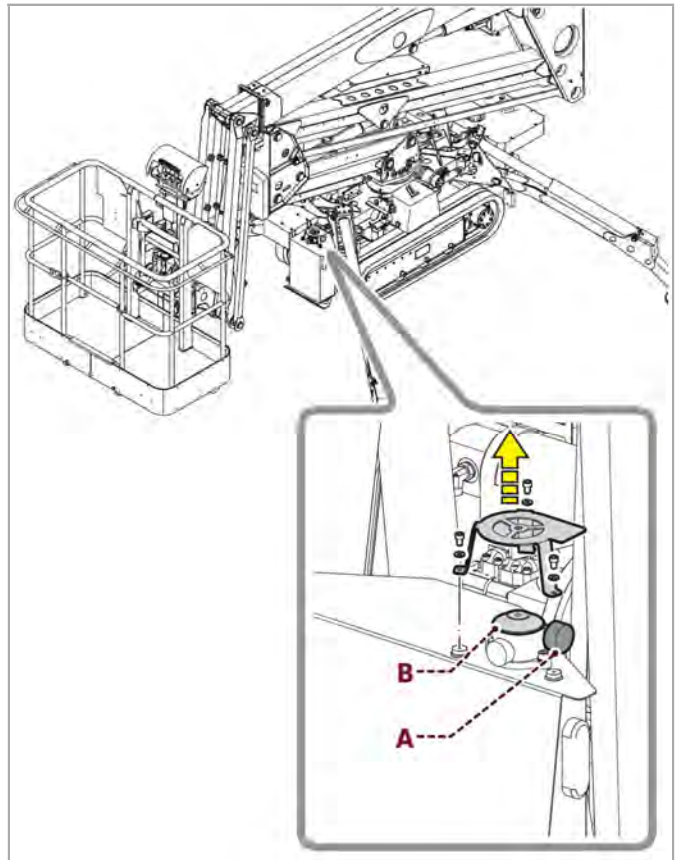

### 11.14. CHECKING AND TENSIONING THE TRACKS

If, during movement, the track, with a high level of bending begins to flap, becoming noisy, it is necessary to tension it.

- Remove the inspection covers (e) (one per side).
- Insert the pump in the end lubricator of the valve (F).
- Inject grease until belt bending is corrected completely.
- If the tension is excessive, loosen the valve (F) so that the excess quantity of grease comes out.



**Caution**

Loosen the (F) valve cautiously.  
Risk of grease ejection.

- Reposition the covers ((E)).

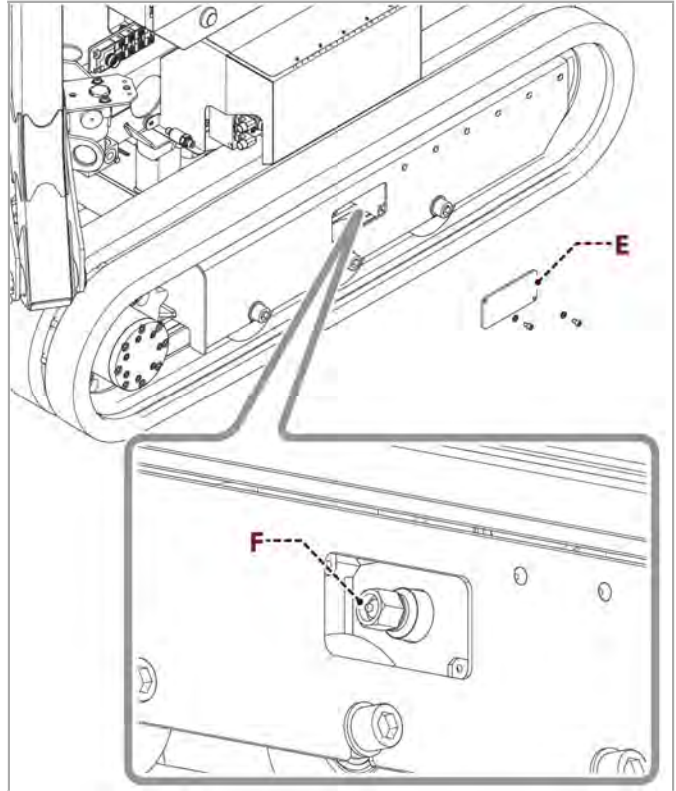

### 11.15. CHECKING FOR WEAR AND WEAR PAD ADJUSTMENT

Check wear of extension shoes; when arm and extensions are re-entered completely and there is still play exceeding **5 mm** between one extension and another they must be replaced.



**Caution**

Replacement of the sliding blocks must be done at an authorized workshop.

Check the centring of the extension and intervene on the registers (A) if necessary. Loosen or tighten the register to move the extension nearer to or further away from the wall.

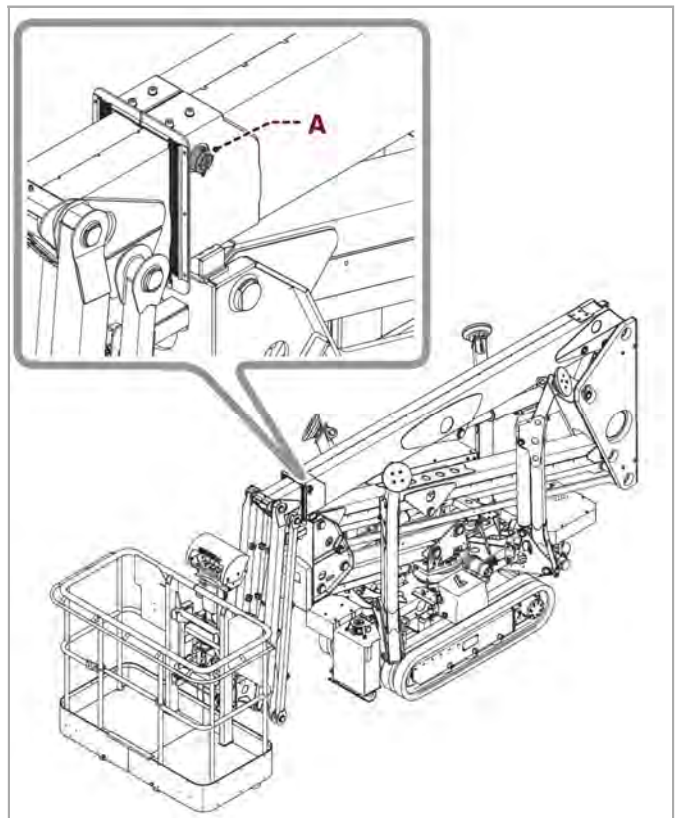

## 11.16. CHECK THE COMBUSTION ENGINE STARTER BATTERY

To avoid injury caused by explosion, do not smoke near the batteries or bring a naked flame or a source of sparking close during maintenance work.



### Caution

Always wear protective goggles when doing maintenance on the batteries.

The batteries do not need maintenance except for the occasional cleaning of the terminals as described below.

- Remove the cables from each terminal of the battery one at a time beginning with the negative terminal;
- Clean the cables with a neutral solution (for example: sodium bicarbonate and water or ammonia) and a metal wire brush;
- Replace the electrical cables or the screws in the terminals if necessary;
- Clean the terminals of the battery with a metal wire brush then reconnect the cables to the terminals;
- Apply mineral grease or vaseline to the surfaces that are not in contact;
- When all the cables and terminals have been cleaned make sure that the cables are secured correctly and not squashed;
- Close the battery housing cover panel.

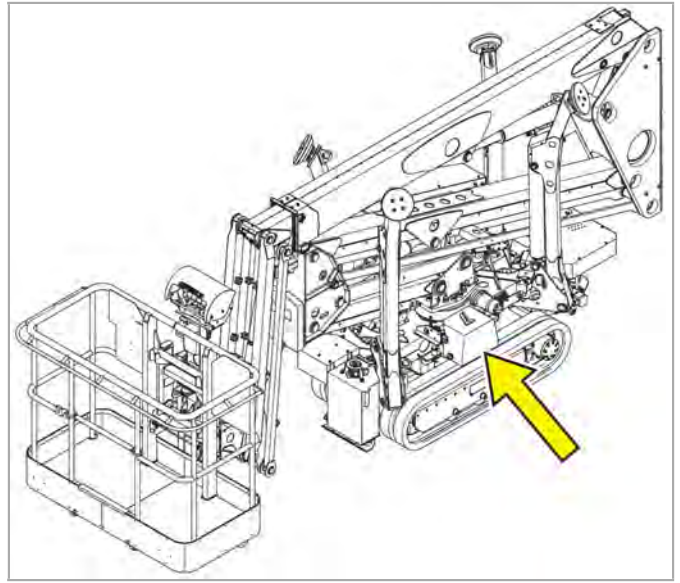

### 11.17. CHECK TIGHTENING

- 1 Stabiliser ring nuts and joints
- 2 Reducer screws
- 3 Component locking screws

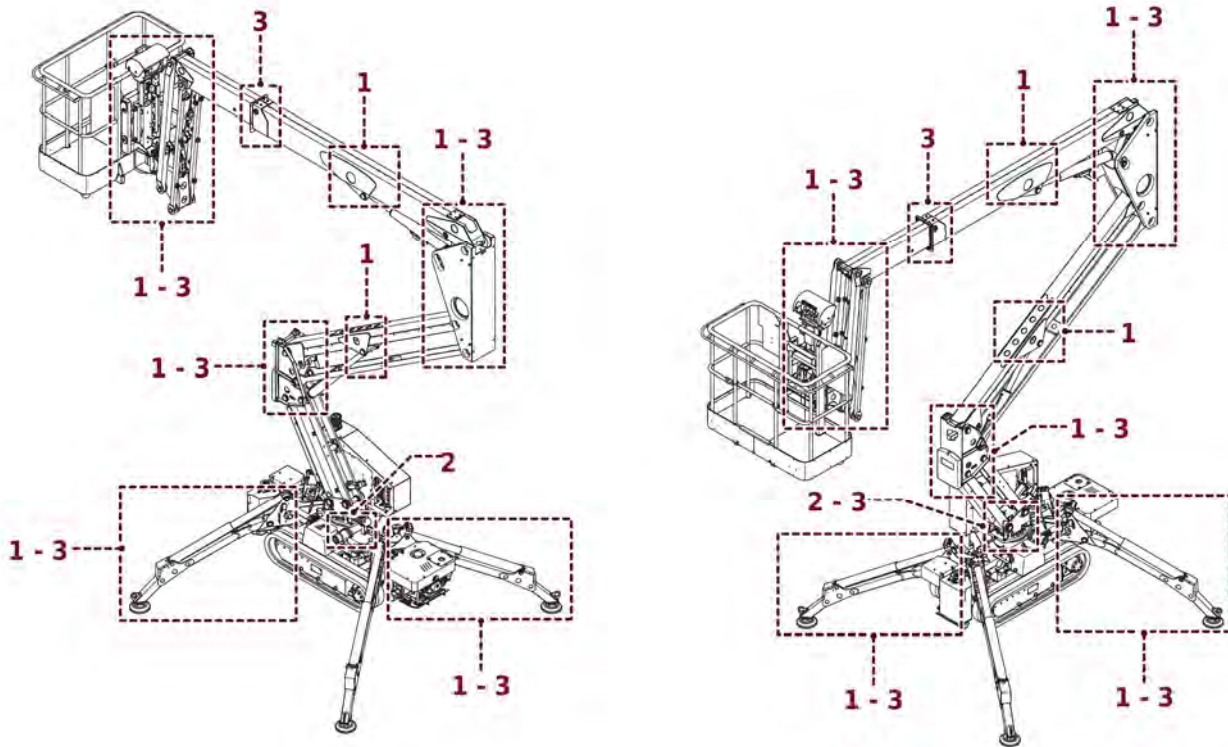

### 11.18. SCREW TIGHTENING

All screws are to be tightened always with a torque wrench.

Excessive tightening of the screws may damage them while insufficient tightening defeats their purpose. Each screw has its own specific value and the calibration of the torque wrench depends on its diameter and type.

If there are a number of screws for the same component (for example the slewing ring, plates, motor-gearboxes) it is necessary to tighten them two at a time in diametrically opposite positions.

Below is the table of values to be used.

#### 11.18.1. SCREW TIGHTENING TABLE

If the screws are lubricated then **60%** of the torque value for tightening is to be used while if the screws are not lubricated then **70%** of the value given in the table is to be used.

##### 11.18.1.1. PRE-LOAD AND TORQUE FOR SCREWS WITH ISO THREAD AND WIDE PITCH

Nominal screw diameter	Max pre-load				Max torque (kgm) Ma (kgm.)			
	6,6	8,8	10,9	12,9	6,6	8,8	10,9	12,9
	6 D	8 G	10 K	12 K	6 D	8 G	10 K	12 K
M4x0,7	222	394	554	665	0,17	0,31	0,43	0,52

M5x0,8	357	635	895	1070	0,33	0,60	0,84	1,01
M6x1	507	902	1270	1520	0,58	1,03	1,46	1,75
M7x1	728	1300	1820	2180	0,94	1,69	2,36	2,83
M8x1,25	920	1640	2310	2770	1,39	2,48	3,49	4,19
M9x1,25	1210	2160	3050	3630	2,05	3,67	5,18	6,17
M10x1,5	1480	2600	3660	4380	2,83	4,97	7,00	8,37
M12x1,75	2120	3780	5320	6380	4,74	8,46	11,90	14,30
M14x2	2890	5160	7250	8700	7,54	13,46	18,92	22,70
M16x2	3950	7020	9900	11900	11,50	20,40	28,80	34,60
M18x2,5	4840	8600	12100	14500	16,00	28,40	40,00	48,00
M20x2,5	6160	11000	15450	18500	22,20	39,60	55,60	66,60
M22x2,5	7630	13600	19100	22900	30,00	53,00	74,50	90,00
M24x3	8900	15900	22300	26700	39,00	70,00	98,00	117,00
M27x3	11500	20600	28900	34700	56,00	101,00	142,00	170,00
M30x3	14100	25200	35400	42400	77,00	138,00	193,00	232,00

The pre-load has been calculated as **70%** of the minimum yield load.

The torque has been calculated using the formula **(39)** of the junker & blume manual, and giving a friction coefficient  $\mu$  ges the average value  **$\mu$  ges = 0,14**.

### 11.18.1.2. Pre-load and torque for screws with ISO thread and small pitch

Nominal screw diameter	Max pre-load				Max torque (kgm) Ma (kgm.)			
	6 D	8 G	10 K	12 K	6 D	8 G	10 K	12 K
	6,6	8,8	10,9	12,9	6,6	8,8	10,9	12,9
M8x1	995	1750	2470	2960	1,48	2,60	3,70	4,40
M10x1,25	1540	2740	3860	4630	2,90	5,20	7,30	8,70
M12x1,25	2420	4140	5800	6980	5,30	9,10	12,80	15,40
M12x1,5	2220	3960	5570	6680	5,00	8,90	12,50	15,00
M14x1,5	3150	5600	7880	9450	8,00	14,30	20,00	24,00
M16x1,5	4200	7500	10500	12600	12,00	21,50	30,00	36,00
M18x1,5	5430	9700	13600	16300	17,40	31,00	43,00	52,00
M20x1,5	6900	12100	17150	20600	24,40	43,00	61,00	73,00
M22x1,5	8400	15000	21000	25200	32,00	57,50	80,50	97,00
M24x2	9650	17200	24200	29000	41,00	73,50	103,00	124,00

M27x2	12500	22300	31300	37500	60,00	107,00	150,00	180,00
M30x2	15700	27800	39200	47000	83,00	147,00	208,00	250,00

The pre-load has been calculated as **70%** of the minimum yield load.  
The torque has been calculated using the formula **(39)** of the junker & blume manual, and giving a friction coefficient  $\mu$  ges the average value  **$\mu$  ges = 0,14**.

### 11.19. CHECKING SENSORS AND MICROSWITCHES

Check that the sensors and microswitches installed are intact and in good working order.  
Simulate the intervention of the activated device. It should prevent the functions or movements it controls. If the manoeuvre or function is activated anyway, contact an authorised workshop to restore normal safety conditions.

The sensors to check are described in the "6 devices" chapter.

### 11.20. CHECK EMERGENCY BUTTONS

Check that the individual emergency buttons work correctly.  
When the machine is on, press one of the mushroom-head buttons and attempt to perform a manoeuvre. This should be prohibited. If it is activated anyway, switch the machine off and contact an authorised workshop to restore normal safety conditions.

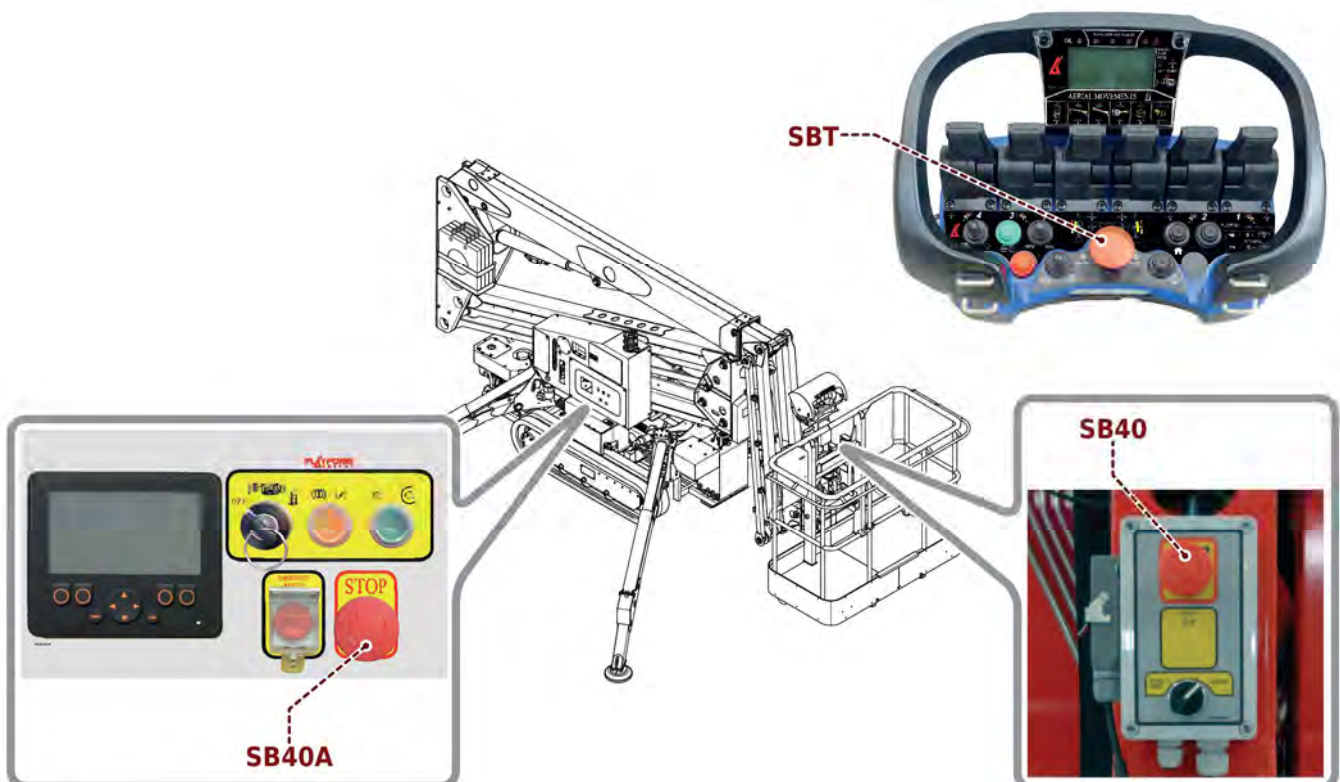

## 11.21. ELECTRICAL MAINTENANCE



### Caution

The machine must be isolated from all power supplies.

### 11.21.1. FUSE REPLACEMENT

Disconnect the fuse in question and replace it with one of the same amperage.

#### Diesel engine

**F1P 255A** Engine battery

**FUM 30A** Starting the engine

**FUB 30A** General electrical system

#### Lithium batteries

**FUI 355A** Power inverter

#### Gasoline drive

**F1P 160A** Engine battery

**FU 30A** Tachometer dynamo

**FUB 30A** General electrical system.

Refer to machine general wiring diagram, to identify any additional circuit breakers (Relay, circuit breakers, etc).

## 11.22. PLACING THE MACHINE OUT OF SERVICE FOR A PROLONGED PERIOD OF DISUSE

In the event of prolonged disuse perform the following operations on the machine.

- Thorough cleaning.
- Lubrication of all moving parts.
- Anti-rust surface treatment on all unpainted metal parts (Apply oil or spray **MoS2**).
- Cover the machine with a waterproof tarpaulin to protect it from dust and damp.
- Disconnect the batteries by turning the battery cut-off switch to the OFF position.

## 11.23. ANNUAL OPERATING TESTS

According to the **UNI-EN 280-2013** standard, the machine must be subject to annual operating tests.



### Note

The frequency, the extension of periodic examinations and tests depend on the regulations in the machine's Country of use.

The operating tests must show that:

- a) The mobile elevating work platform can work regularly for all movements, while transporting the **100%** of the rated load at the rated speeds.
- b) All safety devices intervene correctly.
- c) The maximum allowed speeds are not exceeded.
- d) The maximum allowed acceleration and deceleration speeds are not exceeded.

## 12. SCRAPPING AND DISPOSAL

### 12.1. WARNING

The manufacturer of the machinery does not require any special precautions at the time of disposal because more than **90%** (by weight) of the machines is made of recyclable materials.

The machine should be scrapped adopting safety measures that take account of the logistic and environmental conditions and the state of wear.

Nonetheless, follow the general rules below:

- Wear protective clothing and accessories (helmet, safety footwear, gloves, and safety spectacles and facemask if necessary) approved in accordance with statutory safety legislation.
- Disconnect the machine from all energy sources.
- Check all pressurised systems, depressurising them if necessary.
- Render the machine inoperative and impossible to use by breaking a number of vital machine organs and transfer it to a safe place where nobody can gain access to it.
- Use suitable lifting means as indicated in the “Transport” section of the “Lifting systems” chapter.
- Break the latches on the doors of the machine and of the enclosures where persons or animals could get trapped.
- Break down the machine into easily transportable units.
- To dispose of the machine separate non-polluting materials from polluting materials (electrical insulation, plastics, rubber, etc.).
- Never set fire to the machine or part of it, since the products of combustion of plastic materials and paints may develop noxious and polluting gases.
- Concerning the laws on “SAFETY IN THE WORK ENVIRONMENT” take all the instructions in this manual into consideration and, in particular, all the paragraphs marked with the symbol.



#### **Caution**

The machine should ideally be scrapped and disposed of by specialised and qualified personnel who are in possession of specific information and equipment for this type of operation.

## 13. LOG OF THE OPERATIONS DONE ON THE MACHINE

### 13.1. MAINTENANCE RECORDS AND LOGBOOK

This inspection record is issued by the manufacturer to the platform owner in compliance with annex I of Directive **2006/42/CE**.

The inspection record is to be considered as a part of the machine and must accompany it throughout its life until it is finally demolished.

In the register it is necessary to record the following situations in regard to the life of the machine:

- transfers of ownership.
- replacement of motors, mechanisms, structural elements, electrical components, hydraulic components, safety devices and their related components.
- Significant faults with their relative repairs.
- Routine inspections.

**Note**

If there are not enough sheets in the record, add other sheets as necessary, photocopying them or drawing them up in the same way as the ones present.

On the additional sheets, the user will indicate the type of platform, the factory serial number and the year of manufacture so that they can become an integral part of this record.

**Note**

For the timeline of the maintenance operations to be carried out, see chapter “scheduled maintenance table” of the machine's use and maintenance manual.

### DELIVERY OF THE PLATFORM TO THE FIRST OWNER

Platform work type:

-

Serial number:

Year of manufacture:

Referred to in this logbook, was handed over:

By PLATFORM BASKET S.r.l. on:

to the company:

with registered address at:

According to the conditions agreed, with the technical characteristics, dimensions and functions specified in this instruction manual and in the summary contained in this Register.

**Platform Basket S.r.l.**

**SUCCESSIVE CHANGES OF OWNERSHIP**

Date:

The ownership of the WORK  
PLATFORM:described in this manual is  
transferred to the Firm/Company:

It is hereby certified that, at the date mentioned above, the technical specifications, dimensions and functions of the WORK PLATFORM described in this manual conform to those originally existing and that any modifications have been recorded in this Register.

The Seller:

The Buyer:

**SUCCESSIVE CHANGES OF OWNERSHIP**

Date:

The ownership of the WORK  
PLATFORM:described in this manual is  
transferred to the Firm/Company:

It is hereby certified that, at the date mentioned above, the technical specifications, dimensions and functions of the WORK PLATFORM described in this manual conform to those originally existing and that any modifications have been recorded in this Register.

The Seller:

The Buyer:

**SUCCESSIVE CHANGES OF OWNERSHIP**

Date:

The ownership of the WORK  
PLATFORM:described in this manual is  
transferred to the Firm/Company:

It is hereby certified that, at the date mentioned above, the technical specifications, dimensions and functions of the WORK PLATFORM described in this manual conform to those originally existing and that any modifications have been recorded in this Register.

The Seller:

The Buyer:

**SUCCESSIVE CHANGES OF OWNERSHIP**

Date:

The ownership of the WORK  
PLATFORM:described in this manual is  
transferred to the Firm/Company:

It is hereby certified that, at the date mentioned above, the technical specifications, dimensions and functions of the WORK PLATFORM described in this manual conform to those originally existing and that any modifications have been recorded in this Register.

The Seller:

The Buyer:

**13.1.1. MAINTENANCE RECORDS**

The user is obliged to respect the maintenance and inspection schedule in this instruction manual.

**Key to the frequency of the operation:**

- A - if necessary
- B - day
- C - week
- D - month
- E - two-month period
- F - three months
- G - six months
- H - year

**NO. INTERVENTION**

.....

Periodicity of maintenance:
Work hours:
Date:
Description of action:
Signature

**NO. INTERVENTION**

.....

Periodicity of maintenance:
Work hours:
Date:
Description of action:
Signature

**NO. INTERVENTION**

.....

Periodicity of maintenance:
Work hours:
Date:
Description of action:
Signature

**NO. INTERVENTION**

.....

Periodicity of maintenance:
Work hours:
Date:
Description of action:
Signature

**NO. INTERVENTION**

.....

Periodicity of maintenance:
Work hours:
Date:
Description of action:
Signature

**NO. INTERVENTION**

.....

Periodicity of maintenance:
Work hours:
Date:
Description of action:
Signature

**NO. INTERVENTION**

.....

Periodicity of maintenance:
Work hours:
Date:
Description of action:
Signature

**NO. INTERVENTION**

.....

Periodicity of maintenance:
Work hours:
Date:
Description of action:
Signature

**NO. INTERVENTION**

.....

Periodicity of maintenance:
Work hours:
Date:
Description of action:
Signature

**NO. INTERVENTION**

.....

Periodicity of maintenance:
Work hours:
Date:
Description of action:
Signature

**NO. INTERVENTION**

.....

Periodicity of maintenance:
Work hours:
Date:
Description of action:
Signature

**NO. INTERVENTION**

.....

Periodicity of maintenance:
Work hours:
Date:
Description of action:
Signature

**NO. INTERVENTION**

.....

Periodicity of maintenance:
Work hours:
Date:
Description of action:
Signature

**NO. INTERVENTION**

.....

Periodicity of maintenance:
Work hours:
Date:
Description of action:
Signature

**REPLACEMENT PART RECORD**

Substitution of:

- Mechanical component
- Electric component
- Hydraulic component
- Other

Date

Replaced by:

Replaced element:

Description of new element:

Manufacturer:

Supplied by:

Reason for the replacement:

Notes:

The representative of the company  
responsible for the replacement:

The user:

**REPLACEMENT PART RECORD**

Substitution of:

- Mechanical component
- Electric component
- Hydraulic component
- Other

Date

Replaced by:

Replaced element:

Description of new element:

Manufacturer:

Supplied by:

Reason for the replacement:

Notes:

The representative of the company  
responsible for the replacement:

The user:

**REPLACEMENT PART RECORD**

Substitution of:

- Mechanical component
- Electric component
- Hydraulic component
- Other

Date

Replaced by:

Replaced element:

Description of new element:

Manufacturer:

Supplied by:

Reason for the replacement:

Notes:

The representative of the company  
responsible for the replacement:

The user:

**REPLACEMENT PART RECORD**

Substitution of:

- Mechanical component
- Electric component
- Hydraulic component
- Other

Date

Replaced by:

Replaced element:

Description of new element:

Manufacturer:

Supplied by:

Reason for the replacement:

Notes:

The representative of the company  
responsible for the replacement:

The user:

**REPLACEMENT PART RECORD**

Substitution of:

- Mechanical component
- Electric component
- Hydraulic component
- Other

Date

Replaced by:

Replaced element:

Description of new element:

Manufacturer:

Supplied by:

Reason for the replacement:

Notes:

The representative of the company  
responsible for the replacement:

The user:

**REPLACEMENT PART RECORD**

Substitution of:

- Mechanical component
- Electric component
- Hydraulic component
- Other

Date

Replaced by:

Replaced element:

Description of new element:

Manufacturer:

Supplied by:

Reason for the replacement:

Notes:

The representative of the company  
responsible for the replacement:

The user:

## **14. ENCLOSED DOCUMENTATION**

### **14.1. HYDRAULIC SYSTEM**

## 14.2. ELECTRICAL SYSTEM

### **14.3. CE CONFORMITY DECLARATION**

The EC statement of conformity is the document signed by the manufacturer which guarantees and certifies that the machine complies with all the safety regulations.

The EC statement of conformity is attached to this manual.