

MINI-CRAWLER CRANE

MODEL

URW295CP1UR SERIES
URW295SCP1UR SERIES

OPERATION & MAINTENANCE MANUAL

FURUKAWA UNIC CORPORATION

HEAD OFFICE : Nihonbashi nishikawa Bldg, 5-3, Nihonbashi
1-chome, Chuo-ku, Tokyo 103-0027, Japan

OMURW295CP1UR201602B
PRINTED IN JAPAN

Request to those who operate the crane

The operator's manual describes correct operation methods, simple inspection, and service for the UNIC crane.

Be sure to read this manual carefully to carry out correct and safe operation of the crane. Operate the crane after you have understood the contents of this manual.

Although we take all possible measures to ensure quality of the crane, you are requested to contact our business offices, UNIC sales agents, or authorized service stations whenever you have anything you do not understand.

◆ **For making inquiries**

When making inquiries, ordering spare parts, and requesting repairs, be sure to inform us of the crane model, specification, serial number, and code number which are indicated on the name plate.

◆ **Name plate** of the machine is located at the rear side of column.

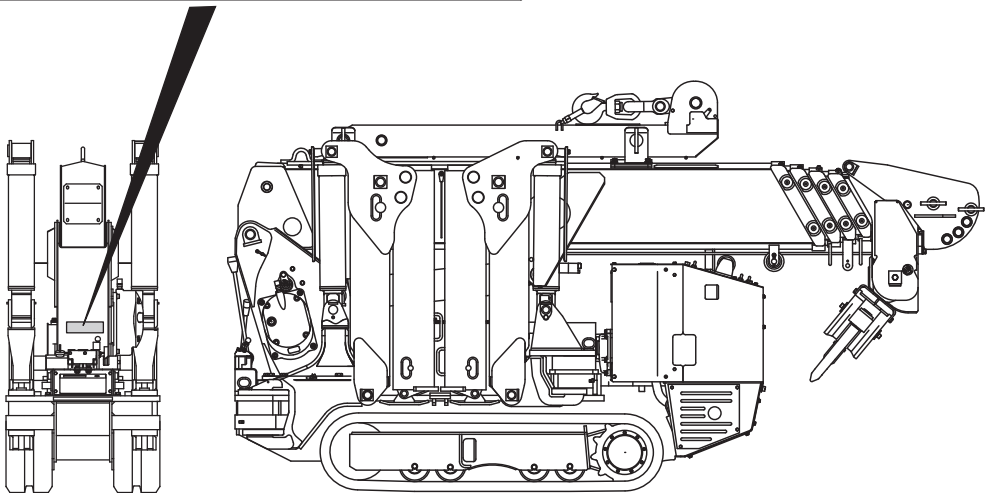
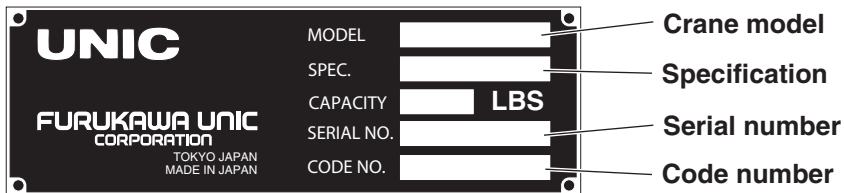

TABLE OF CONTENTS

SETUP OF THIS MANUAL	0- 4	8. HOW TO REFER TO WORKING RANGE CHART AND RATED LOAD CHART	
1. FOR SAFETY OPERATION		① Working range chart	8- 1
① Request to operators	1- 1	② Rated load chart	8- 2
2. SAFETY PRECAUTIONS ON CARRIER OPERATION		9. DESCRIPTION OF EACH CONTROL DEVICE	
① Before operation	2- 1	① Overwinding alarm	9- 1
② During operation	2- 2	② Automatic stop for over-winding.....	9- 2
③ Safe leading & unloading of the carrier/traveling on inclines ...	2- 3	③ Boom angle chart	9- 3
④ After operation	2- 4	④ Warning horn	9-10
3. SAFETY PRECAUTIONS ON CRANE OPERATION		⑤ Hook safety latch.....	9-11
① Before operation	3- 1	⑥ Automatic stop for leaving minimum wire rope (With wire rope retaining roller) ...	9-11
② During operation	3- 2	⑦ Specifications on turnover prevention device	9-12
③ After operation	3- 3	10. HOW TO OPERATE CARRIER	
4. DESCRIPTION OF CARRIER EQUIPMENT	4- 1	① Designation of each control lever and its location ...	10- 1
5. DESCRIPTION OF CRANE EQUIPMENT	5- 1	② Preparation before operation	10- 2
6. NAME PLATES		③ How to operate	10- 3
① Description of name plates (Stickers)	6- 1	④ How to Crawl	10- 6
② Stickers in detail	6- 2	11. HOW TO OPERATE CRANE	
7. DEFINITION OF TERMS		① Designation of each control lever and its location ...	11- 1
① Extension and spread of outriggers	7- 1	② Preparation before operation	11- 2
② How boom-sections are extended	7- 3	③ Procedures to set up outriggers	11- 3
③ Net rated load	7- 4	④ How to operate boom for “derricking” (raising and lowering) ...	11- 7
④ Rated load	7- 4	⑤ How to hoist and lower the hook	11- 8
⑤ Lifting capacity	7- 4	⑥ How to telescope boom	11-10
⑥ Working radius	7- 4	⑦ How to slew boom	11-11
⑦ Boom length	7- 4	⑧ How to handle extension jib	11-15
⑧ Boom angle.....	7- 4		
⑨ Lift above ground	7- 4		

⑨ How to handle searcher hook 11-23
 ⑩ How to remove and fit bracket 11-24
 ⑪ How to store crane 11-25
 ⑫ Procedures for storing hook 11-26
 ⑬ How to store outriggers 11-28
 ⑭ How to switch manual operation mode
 to/from radio remote control mode ... 11-30
 ⑮ How to operate outriggers
 when in an emergency ... 11-32

12. U-WAVE, Radio RADIO REMOTE CONTROL DEVICE

① Request to those who operate the crane 12- 1
 ② Safety precautions 12- 2
 ③ Designation of each equipment 12- 5
 ④ Inspection before crane operation 12- 8
 ⑤ How to switch crane operation mode 12-10
 ⑥ How to operate the crane through
 radio control operation 12-12
 ⑦ How to replace batteries of transmitter 12-34
 ⑧ Daily checks, trouble inspection 12-37

13. MAINTENANCE AND INSPECTION OF CARRIER

① Inspection before operation 13- 2
 ② Inspection and Maintenance which is to be carried
 out every 250 hours or 3 months 13- 9
 ③ Storage 13-11
 ④ Fitting safety covers 13-12
 ⑤ Maintenance and inspection of engine 13-12

14. MAINTENANCE AND INSPECTION OF CRANE

① Inspection before operation 14- 2
 ② Cleaning 14- 3
 ③ Inspection of bolts mounting
 slewing bearings 14- 3
 ④ Replacement of wire rope
 (for winding-up) 14- 4
 ⑤ Replacement of expendable parts 14-10

15. LUBRICATION TO CARRIER

① Precaution when carrying out
 lubrication 15- 1
 ② List of recommended lubricant 15- 2
 ③ Lubrication chart (carrier part) 15- 3

16. LUBRICATION TO CRANE

① Precaution when carrying out
 lubrication 16- 1
 ② List of recommended lubricant 16- 2
 ③ Lubrication chart (crane part) 16- 3
 ④ Lubrication 16- 4

17. MAJOR SPECIFICATIONS

① URW295CP1UR (5-section boom) 17- 1
 ② URW295SCP1UR (5-section boom) 17- 6
 ③ Major specification
 (Radio remote control device) ... 17-11

18. MODE INDICATOR LAMP (Control box)

① Mode indicator lamp (Control box) 18- 1
19. MEASURES TO BE TAKEN IN AN EMERGENCY 19- 1

SETUP OF THIS MANUAL

SETUP OF THIS MANUAL

Crane covered in this manual have some difference in operation in accordance with the specifications of with or without radio remote controller.

Difference in operation due to crane specifications is separately illustrated in this manual for each specification.

Refer to separate “Instruction manual of radio controller” for operation and/or maintenance of the radio remote controller.

1. Designation of specification

Crane covered in this manual are roughly divided into two, types of specification according to maximum boom length. And each type of specification is sub-divided into two according to type with and without remote controller.

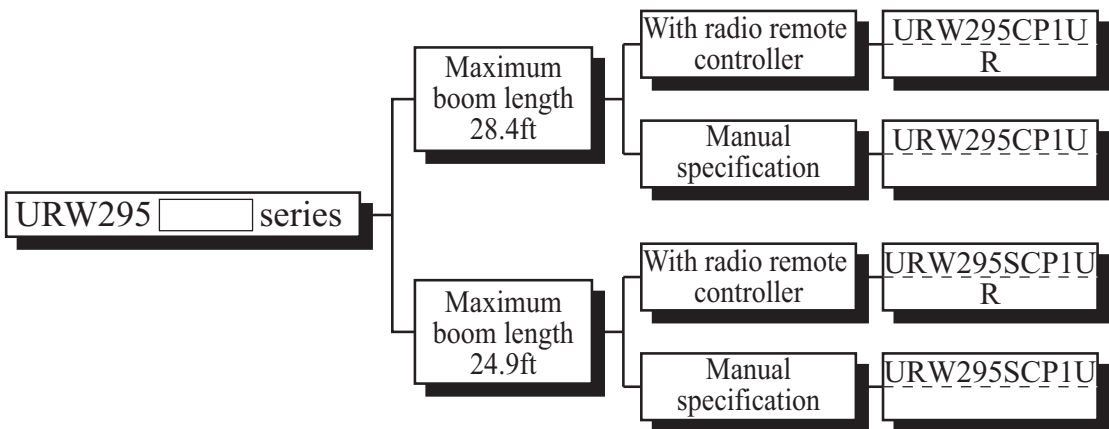

1. FOR SAFETY OPERATION

Observe all the safety regulations !



★ Read preventive measures against danger and cautions stated in this manual for proper understanding.

★ Most accidents related to the crane occur due to operation, maintenance, and inspection which have failed in observing basic safety regulations.

1 Request to customers

- ◆ Never failed to observe **⚠ WARNING** and **⚠ CAUTION** described in the manual as they are of great importance in safety and the crane operation.

⚠ WARNING ... Failure to observe this may invite an accident resulting in injury or death.

⚠ CAUTION ... Failure to observe this may cause damage to the crane.

- ◆ Store this manual where it is easily accessible to read it over and over again.
- ◆ Failure to observe the right operation and maintenance/inspection illustrated in this manual may cause trouble in the crane and may invite an accident, and this will not only shorten its service life but will impair safety in the crane operation. Please remember, in such cases, that no warranty will be given even if the crane is within valid warranty period.
- ◆ In order to prevent injury or death to crane operators and to those who stand close to crane operating area due to operational mistake, caution plates are stuck on the crane. You are requested to read them carefully.
- ◆ Do not alter the crane.
 - ★ If you want to make an alteration, contact with UNIC sales agent or an authorized service shop.
 - ★ If you want to make an alteration, contact with UNIC sales agent or an authorized service shop.

2. SAFETY PRECAUTIONS ON CARRIER OPERATION

WARNING

★ Observe the cautions for securing safety.
Failure to observe the cautions may invite trouble or serious accident.

1 Before operation

1 Dress neatly and wear protectors such as helmet, safety shoes, and gloves without fail.

★ Do not wear baggy clothes and accessories which can be caught by control levers and fittings, and oil-stained working clothes which may catch fire.

2 Be sure to make inspection before operation and periodical voluntary inspection.

If found something wrong, repair it immediately.

3 The crane is prohibited to crawl on a public road by the road traffic law.

4 Check that no safety covers have been left removed.

★ It is very dangerous to start the engine, to operate the crane with the safety cover removed as the driving mechanism is directly exposed.

5 Be sure to stop the engine before refueling or supplying and changing lubricant. A fire source such as smoking cigarette in mouth is strictly prohibited.

Failure to observe this may cause a fire.

6 When starting the engine in a small limited area or indoors, open the windows and doors for well ventilation.

★ Poor ventilation may invite an exhaust gas poisoning.

7 Shift the crane-crawl lever to "Crawl" when crawling the crane.

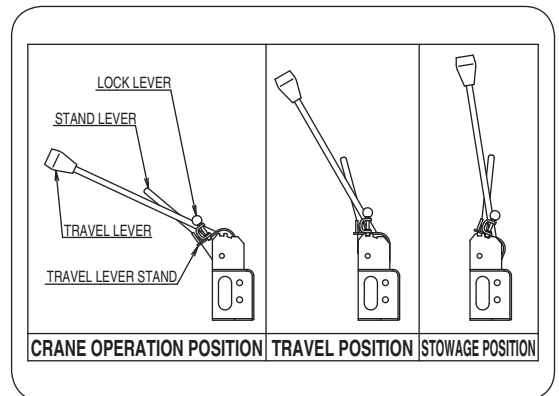

★ Crane will not work unless the crane-crawl lever is shifted to "Crane" position.

SAFETY PRECAUTIONS ON CARRIER OPERATION

2 During Operation

1 This carrier is equipped with especially small mounting platform of narrow width for its size in order to be able to work in narrow spaces. A crane of high capability is mounted on the platform therefore, the position of the gravitational centre is high.

★ Pay special attention to the carrier in order to prevent roll-over when travelling.

2 Keep away from the periphery of the carrier for more than 78.7in. (2 m) other than operators when travelling.

3 When travelling, make sure that the outrigger is being retracted and then retract the hook.

4 Never travel with lifted cargo or without the boom being retracted.

5 When abrupt turning is involved or travelling on a road of a bad condition, make sure to reduce the speed with utmost care.

6 When driven over an irregular road surface or going up and down the slopes, the carrier must get over the slope straight and try not to give any shocks to it.

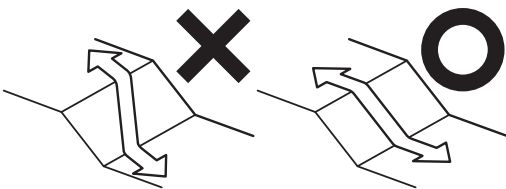

7 When the carrier gets over a gap of the step of 6 in. (15 cm) or more, always use scaffold boards.

8 Pay special attention to the surroundings when travelling.

9 If you have to park the carrier on a slope, make sure to block the rubber crawlers.

10 Make sure to travel at low speed on a slope. Avoid abrupt starts and stops as well as sudden route changes as it may cause slipping depending on the road condition.

11 When you drive up and down the slope, always operate at the upper side of the carrier.

12 Do not operate the carrier on the more steep slope than shows below, as there is a risk of roll-over. Refer to the chapter "3 Straight traveling on the steep slopes and upload/unload the carrier" for the details.

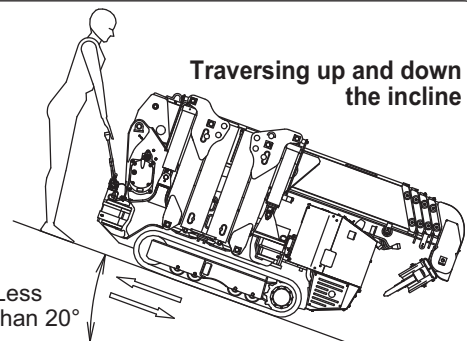

The operator must always drive the carrier from the uppermost position on the incline.

Traversing along the incline

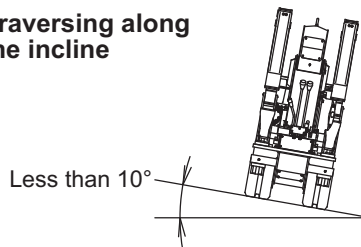

The gradient must be reduced to less than 5 degrees when traversing along the incline on unstable ground or in wet conditions.

Always travel at low speed when traversing any incline and do not make any changes of direction whilst on the incline.

Travelling along an incline or over a step (single track only)

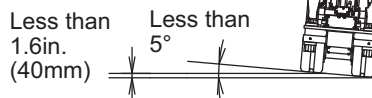

Do not attempt to travel along an incline of more than 5 degrees, or a height of 1.6in. (40mm) when it is only possible to position a single track on the incline.

13 Never travel on the bedrock or sharp stones.

Travelling on bumpy roads or sharp stones such as stony roads at a riverbed, solid rocks with deep concaves and convexes, macadamized ground, iron plate edges or, on the reinforcing bars, iron scraps, scrap materials will suffer a wear and a much shorter life than can usually be expected.

14 When turning the carrier, do not rotate the right and left rubber crawler an opposite direction each other as the abrupt moving can cause excessive wear of rubber crawlers.

15 Never travel with materials or animals on the carrier.

★ There is a risk of injury in case of an abrupt turning or shift of gravity.

16 Do not park the carrier on the flammable materials such as grass or straws.

★ High temperatures of exhaust outlet and exhaust gases can come into contact with flammable materials causing fire.

17 Maneuvers to avoid the damage of rubber crawlers

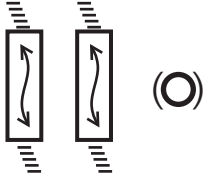
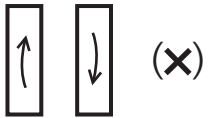
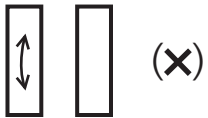
	<p>Make sure to drive both crawlers at the same time to the same direction when turning.</p>
	<p>Do not drive left and right crawler an opposite direction.</p>
	<p>Do not drive only one crawler.</p>

★ Always observe the driving procedure for the white (gray) crawlers because they have some special requirements to follow.

3 Safe leading & unloading of the carrier/traveling on inclines

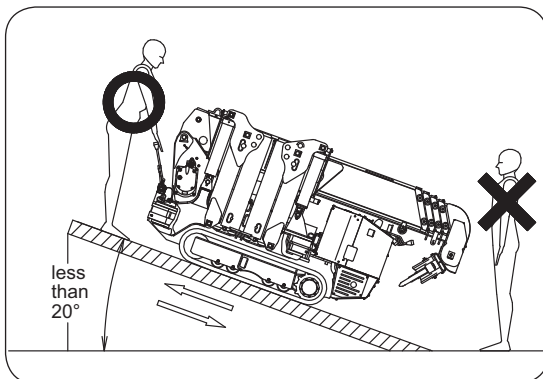

1 Safe loading & unloading of the carrier/travelling on inclines.

★ Always ensure that the gradient of the ramp or surface is not greater than 20 degrees and has sufficient grip.

★ Ensure that the ramp or surface will support the total weight of the crane and the operator.

★ Scaffold boards or other materials not designed for use as ramps must not be used.

★ Ensure that all other persons are kept clear from the carrier during travel.

★ The operator must always drive the carrier from the uppermost position on the incline, i.e. reverse up the incline and follow the carrier down the incline.

★ Never attempt to turn the carrier on an incline, always drive straight up and down.

★ The carrier must always be manoeuvred slowly during travel up and down inclines.

★ In the event that control of the carrier is lost during loading/unloading, do not attempt to stop the carrier from falling.

★ Never stand at the lower side of the carrier.

★ When the carrier is going to slip off, never support it with human hands.

SAFETY PRECAUTIONS ON CARRIER OPERATION

2 Stop the engine, apply the parking brake, and block the wheels of the truck.

★ Otherwise, the truck can start to roll when loading/unloading the carrier resulting a fall accident.

4 ***After operation***

1 Return the crawling lever and run the engine at a low speed.

2 Shift the crawling lever to "Crane" position.

3 Stop the engine and remove dirt and dust stuck on the crane body.

★ Since dust stuck on the battery, electric wiring, and engine related components such as muffler may cause a fire in particular, be sure to remove it.

4 Cover the crane or store it in a storage house to prevent it from being accessed by unrelated persons such as children.

★ Cover the crane after heated sections have been cooled off.

Putting a cover on while the crane body is still hot may cause a fire.

5 Remove the starter switch key to keep it securely.

6 Disconnect a battery cable before the crane is to be stored for a long period of time.

★ Failure to disconnect it may cause a fire as cables short-circuited by gnawing animals such as rat.

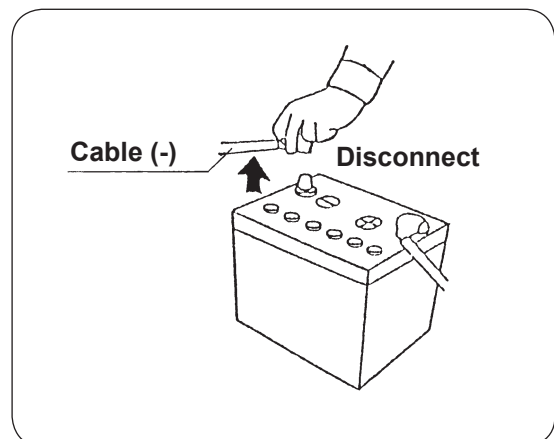

3. SAFETY PRECAUTIONS ON CRANE OPERATION

1 Before operation

1 Be sure to make inspection before operation and periodical inspection for slinging implements.

★ If a defective slinging implement is used, fall of lifted cargo may result.

2 Shift the crawling lever to "Crane" position.

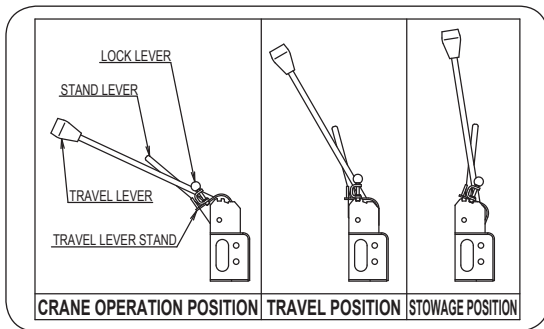

3 Turn ON the overwinding alarm switch.

4 Make sure that each safety device is always functioning properly.

★ Be sure to turn ON the over-winding alarm switch before starting crane operation.

5 Keep a safety distance away from the high-voltage power line to avoid an electric shock.

★ The crane is not electrically insulated.

6 Do not operate the crane when wind velocity exceeds 22.5mph (10m/sec.) and/or while thundering.

★ Crane operation while strong wind is blowing can cause fall of a lifted cargo or overturn of the crane as the boom and/or a lifted cargo are hit by a gust of wind.

7 Pay attention that anyone except persons concerned will not enter within a working radius of the crane.

★ Take good care to carry out safety operation by keeping a close watch around the working area.

8 Make sure that the ground on which outriggers are to be set up is solid and firm.

★ When setting up the outriggers on an unlevelled ground or on a slope, be sure to place a support (such as plank, steel plate etc.) under the outrigger foot flanges to keep the crane level.

In addition, when the crane is to be operated on a soft ground, take the same measures to prevent the outrigger foot flanges from sinking into the ground when a cargo is lifted up.

9 Lift up the crawler by approx. 2in (50mm) from the ground.

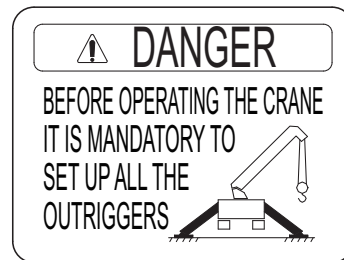

10 Operation with the crane kept leaning makes it unstable when a cargo is lifted up. Such operation can cause the crane to be overturned.

11 In normal crane operation, be sure to set up the crane level with the outriggers fully extended.

12 Do not stand under or in front of the hook when unhooking as it swings.

13 Do not try adjusting hydraulic equipment.

14 Confirm that the crane makes an automatic stop by turnover prevention device when overloaded.

SAFETY PRECAUTIONS ON CRANE OPERATION

2 *During operation*

1 Pay attention that the hook will not be over-wound.

Be sure to turn ON the "over-winding alarm switch".

★ Remember that the hook is wound up when boom is extending.

★ If the hook hits against the boom top due to being over-wound of the hook, it may cause damage to wire rope and the sheaves at the boom top and may cause the fall of lifted cargo.

2 Operate each lever slowly and smoothly.

★ An abrupt lever operation with a cargo lifted gives an excessive shock to the crane which may cause damage to the crane and/or overturn due to swing of a lifted cargo.

★ If a control lever will not make a smooth return to its neutral position, carry out lubrication and repair as soon as possible.

3 Slew the crane at low speed.

★ Swing of a lifted cargo increases working radius of the crane which may cause it to be overloaded.

4 If the engine speed is too slow when operating the crane, control the accelerator lever to increase it.

★ Crane operation with the engine (and pump) running at low speed may cause a cargo hoisted up to swing due to pulsation of the engine.

This is not a malfunction but impairs smooth control of the crane.

5 Overloaded operation is strictly prohibited.

★ Crane operation with a load exceeding the rated load hoisted may cause damage or overturn to the crane.

★ Do not put too much confidence on the turnover prevention device.

It functions just as an auxiliary device.

It is the principle that you should persistently observe the operation within rated load.

If an alarm sounds due to decrease of ground reaction, lower the operating speed immediately to shift the crane to safer side.

★ If ground reaction decreases further, the crane stops following functions automatically when you should pay special attention to the crane because it may roll over due to swing of a lifted cargo.

◎ Winding-up hook ◎ extension of boom
◎ lowering boom ◎ Slewing

6 Pulling a cargo sideways, straight, or obliquely is strictly prohibited.

★ These operation may cause slewing members, booms, columns, and derrick cylinder to be damaged.

7 When a cargo to be lifted is detached from the ground, stop lifting it up temporarily to confirm safety.

★ When a cargo is lifted off the ground, stop lifting it up temporarily to make sure that the cargo is kept horizontally, the crane maintains its stability, and the rope slinging up the cargo is positioned properly.

Then lift it up again after making sure of the safety.

★ For lowering a cargo, stop lowering it immediately before it touches the ground then lower it again gradually.

8 Do not leave from operating position with a cargo hoisted.

★ Lower a hoisted cargo onto the ground before leaving the operation site.

9 Do not get up on a cargo being hoisted.

★ This may cause a fall from the cargo being hoisted.

10 Do not stay under a hoisted cargo.

11 Pay attention that wire ropes will not be paid out unnecessarily to prevent ropes from being wound around the drum irregularly.

★ Operation such as paying out wire ropes further with a cargo placed on the ground, retraction and/or lowering boom which loosen the ropes to cause them irregular winding which results in remarkable shortening service life of the ropes.

★ Wind the first layer of rope firmly and regularly around the drum.

★ Correct kinks of rope immediately with a mallet.

12 Pay extra attention to underground crane work in which the hook must be lowered further than the work on the ground.

★ When paying out wire ropes, be sure that more than 3 turns of rope must always be left on the drum.

13 Stop the crane operation when temperature of hydraulic oil exceeds 147°F (80°C).°C.

★ Oil temperature is apt to rise easily if repeated operation of winding up and down the hook, especially in a high lift, is required.

★ Excessive high temperature of hydraulic oil damages high-pressure hoses and gaskets being employed to cause the oil to spout out so that a scald may result.

14 Do not touch the engine and the hood in the side with a bare finger as they become too hot.

3 After operation

1 Make sure that the booms, the outriggers, and the hook have been stored before crawling the crane.

2 Do not carry out maintenance and inspection while temperature of either hydraulic oil or gear oil is still high.

★ Temperature of both hydraulic and gear oil is high immediately after crane operation so that accumulated high pressure still remains. Removing filling cap, draining oil, or replacing oil filter while temperature is still high allows hydraulic and/or gear oil to spout out and a scald may result.

3 Since temperature on the engine and the hood in the side is too high immediately after crane work, touch them after they have been cooled down.

4. DESCRIPTION OF CARRIER EQUIPMENT

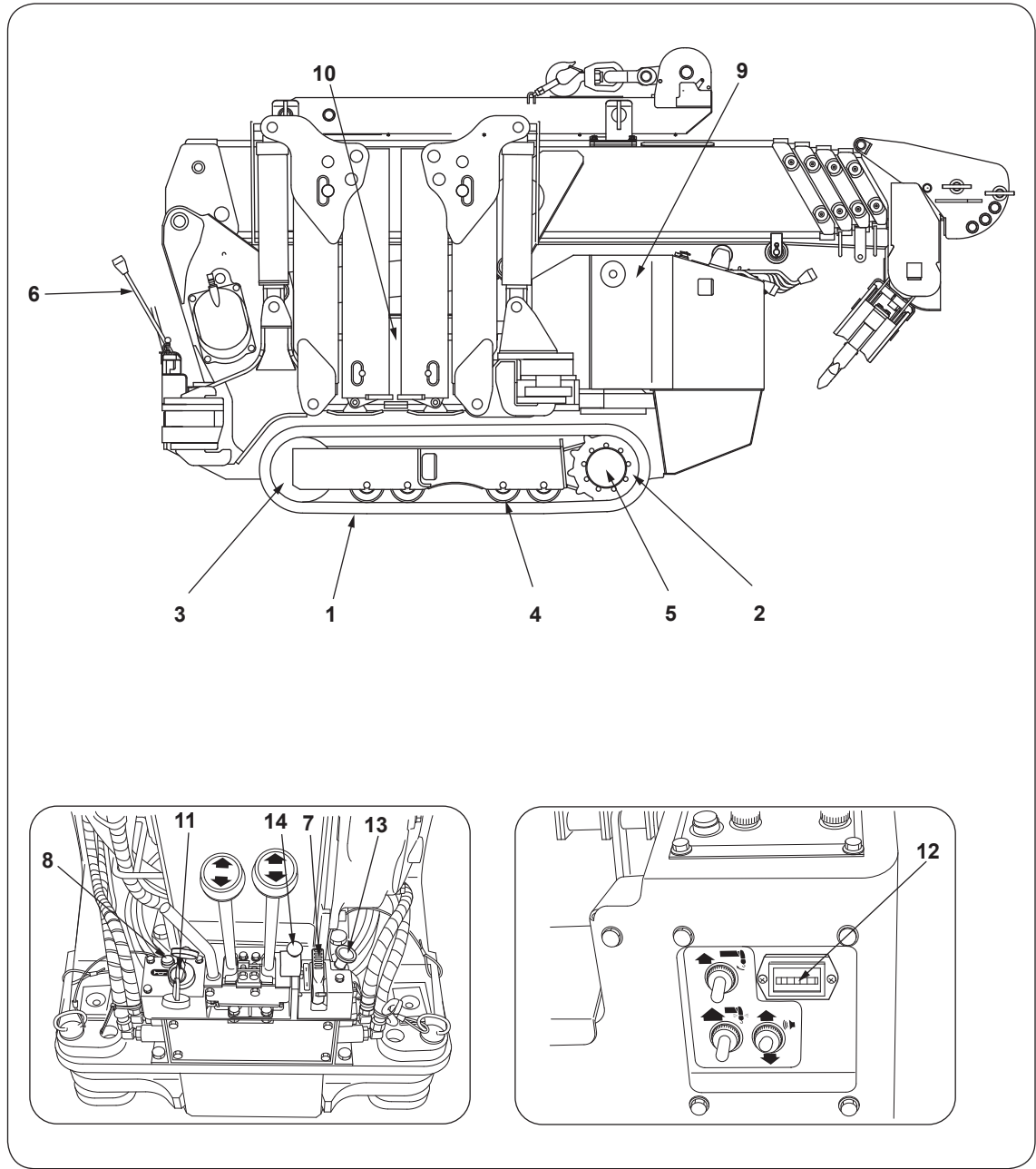

1. Rubber crawler

Cored bar and steel fabric (cords) are integrally molded in the rubber which is of the same quality as automobile tire.

2. Wheel sprocket

It transmits driving power to the rubber crawler to allow the crane to crawl.

3. Idle roller

This is a roller which gives a proper tension to the rubber crawler.

4. Truck roller

This supports the weight of crane and rolls on the rubber crawler.

5. Crawling motor

Hydraulic motor with reduction gears which transmits driving power to the wheel sprocket is built inside.

6. Crawling lever

This is to change crawling speed and direction.

7. Accelerator lever

This is to control engine speed.

8. Horn switch

9. Fuel tank

Fuel to be used is leadless gasoline.

10. Hydraulic oil tank

This is filled with hydraulic oil which commonly supplies both to the carrier and to the crane.

11. Starter switch

This is a switch to start and stop the engine.

12. Hour meter

This indicates total engine running time.

13. Choke knob

This is pulled when starting the engine in cold weather.

14. Lock lever

5. DESCRIPTION OF CRANE EQUIPMENT

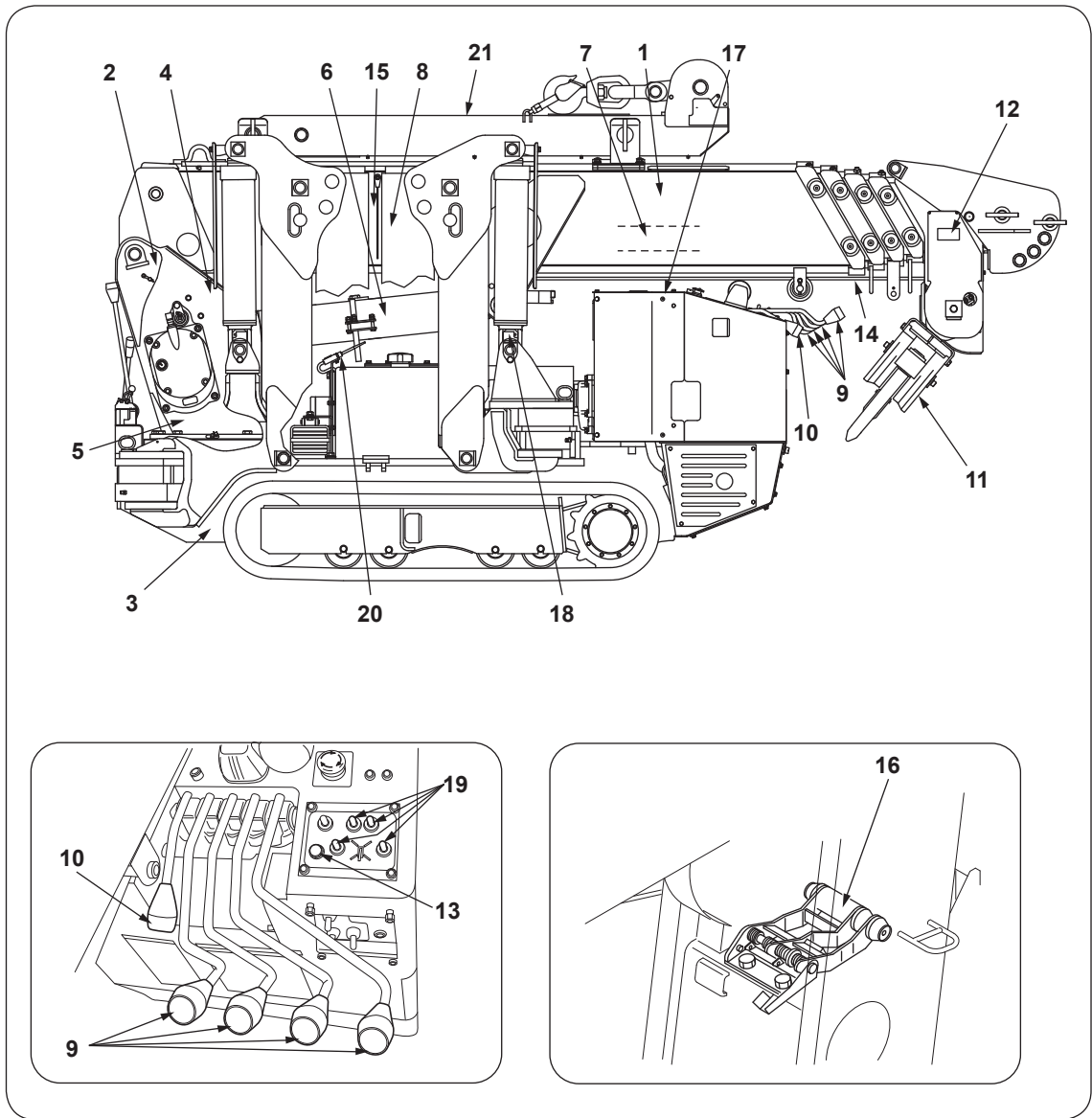

1. Boom

It extends and retracts by hydraulic cylinder and the hook is suspended from its top.

2. Column

This is a vertically mounted member on the crane in which boom, winch, and derrick cylinders are installed.

The column can be turned by slewing device.

3. Frame

This is fixed on the vehicle to support the column and outriggers.

4. Hoist winch

This is a device which rotates the wire drum by hydraulic motor to hoist up and down a cargo via wire ropes.

5. Slewing device

This turns the column by hydraulic motor.

6. Derrick cylinder

This raises and lowers the boom.

7. Telescoping cylinder

This extends and retracts sections of boom.

8. Outrigger

This supports the crane to maintain its stability while it is operated.

9. Crane operating levers

Respective levers control raising and lowering boom, hoisting a cargo up and down, telescoping boom, and slewing boom.

10. Outrigger control levers

Respective levers control raising/lowering and extending/retracting outriggers.

11. Hook

12. Over-winding alarm

When the hook comes close to the boom top, this makes an alarm to warn that wire ropes are to be over-wound.

13. Warning horn

Depression of warning switch sounds the horn for warning.

This is to warn co-workers and others in the operation site.

14. Wire rope

15. Boom angle chart

This can read the working radius value corresponding to extended length of the boom and its raised angle.

16. Automatic stop for leaving minimum wire rope (With wire rope retaining roller)

This is a device to restrict slackening of wire rope on the drum which allows to stop unwinding automatically when remaining wire rope on the drum comes close to 3 turns.

17. Level

This is an instrument for checking horizontal plane of the crane body.

18. Turnover prevention device

This detects load against ground from outriggers.

19. Outrigger selection switch

This selects active outrigger and operating direction.

20. Detector for limit rotation

This device limits the rotation of the boom to avoid hitting the equipment on the cover.

21. Extension jib

MEMO

A series of horizontal lines for writing. The first line is a dotted line, and the subsequent lines are solid. The lines are evenly spaced and extend across the width of the page.

6. NAME PLATES

1 Description of name plates (Stickers)

The machine is provided with stickers indicating caution (framed in box) and specifications as shown in the figure below, and in addition to that there are stickers showing control levers, switches, and instructions for lubrication.

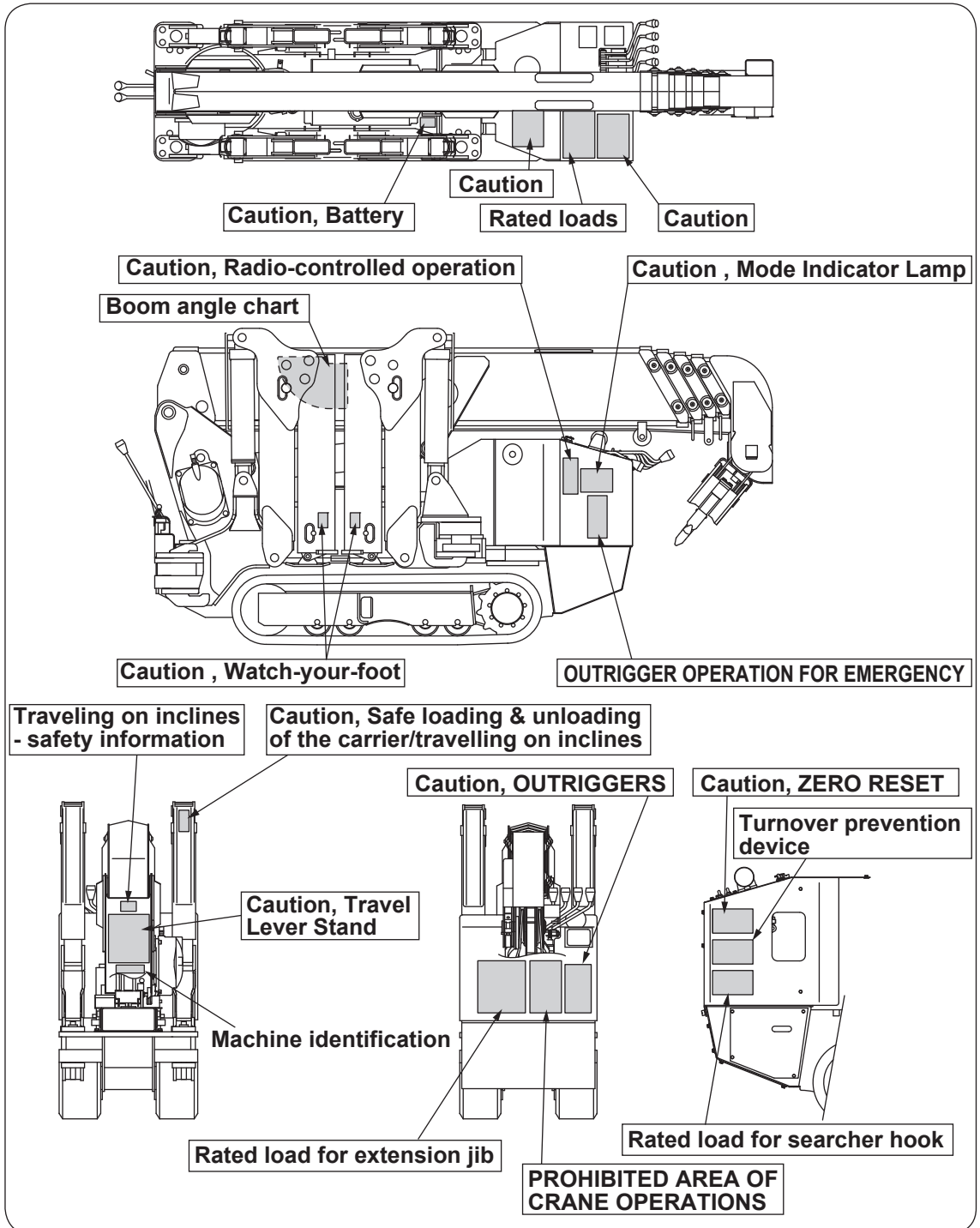

2 Stickers in detail



- ★ Always keep the stickers clean so that they can be read easily.
- ★ If any of the stickers has come off, stick it again or replace it with new sticker.
- ★ When ordering stickers, specify the part number shown at the bottom-right of the sticker concerned.

Sticker [HIGH TEMPERATURE]



Sticker [BATTERY]

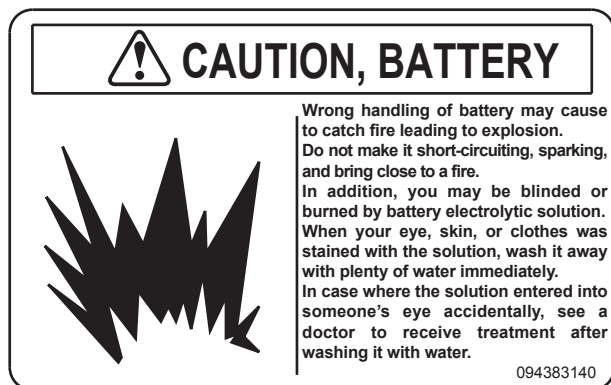

Sticker [WATCH-YOUR-FOOT]



Sticker [OUTRIGGERS]



CAUTION OUTRIGGERS

- Place the crane on a firm and level surface and use the outriggers in principle in "max extended" condition.
- Do not extend outrigger cylinders with outriggers stowed.
- Swing outriggers with outrigger cylinders retracted.
- When extending outriggers, be sure to extend inner boxes and then set up crane by extending outrigger cylinders.
- When stowing outriggers, be sure to retract outriggers fully, stow inner boxes, fold outer boxes and swing outriggers to the stowage position.
- Be sure to insert swing lock pins not to swing outriggers when extending and retracting them.
- Be sure to stow outriggers when traveling.

POSTURE OF MAX EXTENDED OUTRIGGERS

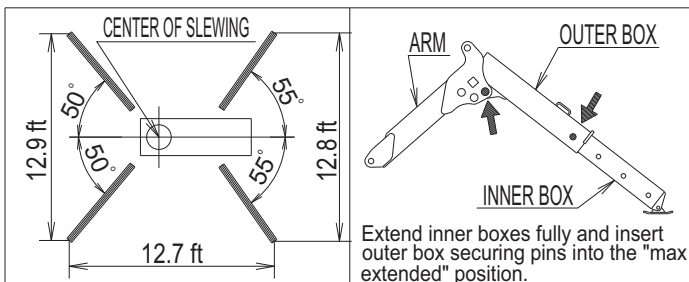

- If either inner boxes or outer boxes are set other than max extended, operate according to other than max extended performance.
- In case of swinging with a load lifted, Shorten the working radius as much as possible and operate carefully with using caution of a turnover. Fore-and-aft stability of the crane is different from right-and-left stability.
- When operating the crane, keep it level by adjusting outriggers.
- In case of changing the posture of each outrigger from the above illustration, operate according to another caution, "Prohibited area of crane operations".

09HQ86071-W295CUR

NAME PLATES

Sticker [CAUTION, CRAWLING]

CAUTION, TRAVELING UNIC

The truck might fall off or fall down during traveling.
Slow down the vehicle and direct your mind to traveling when passing close to road shoulder or on the soft ground.

094383160

Sticker [CAUTION] (Example for URW295CP1UR)

CAUTION

- Read operation & maintenance manual carefully before use.
- When operating this crane, the safety of surrounding area must be ensured.
- Be sure to inspect and maintain before operation.
- Be sure to turn off the power (engine, power, etc.) before inspection and maintenance.
- Inspect and maintain the engine after cooling the motor.
- Things around the engine should always be checked to prevent fire.
- If engine oil decreases, a sensor might stop the engine.
- Be sure to replace all covers properly after inspection and maintenance.
- Place the crane horizontally by using a level.
- Rated load chart shows the performance of this crane on level and firm ground.
- Overloading might cause a turn over of crane. Rated load chart must be observed.
- Do not travel with the load hoisted and operate the crane without outriggers extended. They cause a serious danger.
- Be sure to operate the crane after extending outriggers and putting approx. 50mm between the crane and ground. Operation without putting a space might cause a damage of carriage. Exceeding space might also cause a serious danger.
- Slew at the proper speed not to sway the load. Doing it at the exceeding speed might cause a turn over of the crane.
- When extending the boom, put an adequate space between the boom top and hook.
- Before traveling, be sure to store the hook completely.
- Be sure to turn off the key switch after finishing operation.

WORKING RANGE CHART

WORKING RADIUS (ft)
NOTE: The above chart shows the figures without deflection of boom under no-load condition.

MIND THE SLEWING BOOM

09HQ86031-W295CUR

Sticker [RATED LOAD CHART] (Example for URW295CP1UR)

RATED LOADS

BOOM SECTION	1 • 1+2									
WORKING RADIUS(ft)	3.0	4.5	5.0	6.0	7.0	8.0	10.0	11.0	12.58	
RATED LOAD (lbs)	MAX EXT. OUTRIGGERS	6450	6450	5850	4950	4350	3800	2850	2450	2000
	NOT MAX EXT. OUTRIGGERS	4450	4450	4450	3150	2250	1600	1100	950	600

BOOM SECTION	1+2+3									
WORKING RADIUS(ft)	7.0	8.0	9.5	10.0	11.0	12.0	14.0	15.0	17.62	
RATED LOAD (lbs)	MAX EXT. OUTRIGGERS	3050	3050	3050	2750	2450	2150	1650	1450	1000
	NOT MAX EXT. OUTRIGGERS	1850	1550	1250	1150	1000	850	600	550	300

BOOM SECTION	1+2+3+4									
WORKING RADIUS(ft)	11.0	12.5	13.0	15.0	16.0	17.0	18.0	20.0	22.61	
RATED LOAD (lbs)	MAX EXT. OUTRIGGERS	1950	1950	1750	1350	1200	1100	1000	850	660
	NOT MAX EXT. OUTRIGGERS	1000	800	750	600	510	450	370	280	200

BOOM SECTION	1+2+3+4+5									
WORKING RADIUS(ft)	12.5	13.5	15.0	16.0	18.0	19.0	21.0	23.0	25.0	27.59
RATED LOAD (lbs)	MAX EXT. OUTRIGGERS	1280	1280	1050	920	750	700	590	500	350
	NOT MAX EXT. OUTRIGGERS	850	700	600	530	420	380	300	220	130

CAUTION RATED LOADS

- The rated loads show the performance of the crane on level ground and are based on the actual working radiuses including the deflection of boom under load condition. The rated loads are also based on strength and stability of crane.
- "Max extended outriggers" means inner boxes are extended to the max. extended position and a swing lock pin of each outrigger arm is inserted into the normal position. Other than the above, operate according to figures of "not max ext. outriggers"
- If even one outriggers are not fully extended, operate according to the figures of "not max. ext. outriggers".
- Improper set-up of outriggers may cause a turn over of the crane. Extend outriggers fully and Place them on firm and level ground. Make sure lock pins are inserted properly.
- Boom [1+2+3+4] means boom [4] is extended up to \blacktriangledown mark.
- Operate according to the figures of [1+2+3] when boom [3] is extended even a bit. Do according to [1+2+3+4] when boom [4] is extended even a bit. Do according to [1+2+3+4+5] when \blacktriangledown mark in the side of boom [4] moves away from boom [3] even a bit.

09HQ86040-W295CUR

Sticker [MODE INDICATION LAMP]

CAUTION MODE INDICATOR

INDICATOR (LIT)	OPERATION MODE (STATUS)	MODE INDICATOR LAMP	POSSIBLE OPERATION
00	CRANE MODE	ON	RADIO CONTROL
01		OFF	MANUAL
04	OUTRIGGER MODE	ON	RADIO CONTROL
		OFF	MANUAL
10	OVERWINDING	—	—
13	STORAGE OF HOOK	—	—
14	CANCELLATION OF AUTO-STOP	—	—
15	AUTOMATIC STOP	—	—
95	LEAVING MINIMUM WIRE ROPE	—	—
0F	TRAVEL MODE	—	—

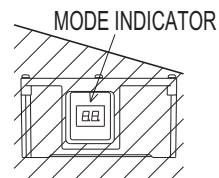

MODE INDICATOR LAMP

- The above table shows the main mode indication. For details, see the instructions.
- The mode selection switch opposite to the mode indicator lamp allows selection of ON and OFF of radio-controlled operation.
- When mode indicator lamp is ON, radio-controlled operation can be performed.
- When mode indicator lamp is OFF, manual operation can be performed.
- Flashing of the mode indicator shows abnormality of operation or the equipment. Follow instructions of the instruction manual.

09HP81010-W095CDE

Sticker [OUTRIGGER OPERATION FOR EMERGENCY]

Sticker [Radio-controlled operation]

⚠ OUTRIGGER OPERATION FOR EMERGENCY

When the outriggers do not operate normally with normal operation methods, operate them in a make-shift manner in the following procedures. When the specific work is complete, have the outriggers inspected and repaired at your nearest service shop of our products as soon as possible.

1. Remove this cover of the outrigger valves.
2. Push the solenoid valve button of the following outriggers to be operated with a narrow rod such as a screwdriver.
3. Operate the outrigger control lever while pushing the solenoid valve button.

OPERATION	OPERATION METHOD	
OUTRIGGER ①	RET.	Push 1 and operate the lever.
	EXT.	Push 2 and operate the lever.
OUTRIGGER ②	RET.	Push 5 and operate the lever.
	EXT.	Push 6 and operate the lever.
OUTRIGGER ③	RET.	Push 7 and operate the lever.
	EXT.	Push 8 and operate the lever.
OUTRIGGER ④	RET.	Push 3 and operate the lever.
	EXT.	Push 4 and operate the lever.

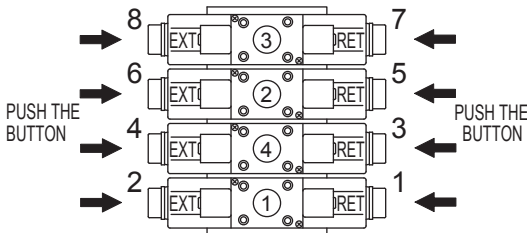

VALVES FOR OPERATING OUTRIGGERS

Note: When removing the cover or pushing the solenoid valve switch, be careful not to damage the wiring.

09R886190-W295CR

⚠ CAUTION Radio-controlled operation

- For approx. two seconds after the key is switched ON, the system is analyzed. Do not operate the crane during this period. If the crane is operated during system analysis, a voice urging "service remote control" is announced. In this case, switch the key ON again.
- When the emergency stop switch in the switch panel or transmitter (remote controller) is turned to "STOP", all crane movements make an emergency stop.
- If the crane does not operate in spite of an announced voice saying "Remote control ready." after the key is switched ON, there is possibility that the emergency stop switch is turned to "STOP." In this case, the crane can be operated if the emergency stop switch is turned to "RESET."
- Be careful that in case of performing hook storage operation with the switch panel of the crane, the manual operating lever also moves with the switch turned to "STORE."
- Be careful that in case of operating the crane with a radio control transmitter, the manual operating lever moves simultaneously.
- If the manual operating lever is moved during radio-controlled operation, the crane stops automatically.
- Operation with a radio control transmitter cannot be performed during manual mode (at the mode indicator lamp "OFF")

09HA81090-W376CDE

Sticker [TRAVEL LEVER STAND]



CAUTION		TRAVEL LEVER STAND	
CRANE OPERATION POSITION	TRAVEL POSITION	STOWAGE POSITION	
<ul style="list-style-type: none"> ■ When changing the position of the travel lever stand, be sure to change the position by holding the stand lever instead of the travel lever. <p>CRANE OPERATION POSITION</p> <ul style="list-style-type: none"> ■ When operating a crane, pull up the lock lever and tilt the travel lever stand toward you. ■ Tilt the travel lever stand until it contacts the stopper. If the crane is operated without the travel lever stand tilted to the end, the travel lever may contact the main body of the crane while the crane is swung, resulting in breakage. ■ Be careful not to contact the travel lever while operating the crane. The contact activates the crawler, which is dangerous. <p>TRAVEL POSITION</p> <ul style="list-style-type: none"> ■ When travelling, set the travel lever stand to the travel position. Be sure to secure the stand with the lock lever. ■ When the travel lever stand is set to the travel position, the crane does not operate at all except for travelling. ■ When changing to the travel position, be sure to slow the boom and outriggers and position the crane to the travel position. Travelling without positioning the crane to the travel position may cause a serious accident such as turn over. <p>STOWAGE POSITION</p> <ul style="list-style-type: none"> ■ When transporting a crane, pull up the lock lever and tilt the travel lever stand toward the column. ■ Even when the travel lever stand is in the stowage position, operation of the travel lever actuates the carriage if the hydraulic pump operates. Use due care when changing the position. 			
09R88620-W295CR			

Sticker [PROHIBITED AREA OF CRANE OPERATIONS]

PROHIBITED AREA OF CRANE OPERATIONS		
<p>Orange areas in each outrigger placement shows prohibited areas of crane operations.</p>		
	<p style="text-align: center;">CENTER OF SLEWING</p>	
	<p style="text-align: center;">NORMAL EXTENDED CONDITION</p>	
<ul style="list-style-type: none"> ■ Perform operations with outriggers extended in each illustration so that the position of a lifted load does not go beyond white areas. ■ Never perform operations in orange areas, because the crane may turn over. ■ Be sure to set any two adjacent outriggers of the four outriggers to normal extension (front 55 degrees, rear 50 degrees) as shown in the above illustrations. If any one of the four outriggers is not fully extended, operate with performance of not maximum extension. ■ Be sure to insert the swing lock pins to prevent the outriggers from rotating. 		
09R88620-W295CR		

NAME PLATES

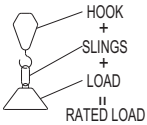
Sticker [CAUTION] (Example for URW295CP1UR)

<p>⚠ CAUTION RATED LOAD</p> <p>Weights of hook (66 lb), slings, and any accessories to the boom or loadline must be deducted from the rated loads.</p> <div style="text-align: center;">  <p>HOOK + SLINGS + LOAD = RATED LOAD</p> </div> <div style="border: 1px solid black; padding: 2px; text-align: center; margin: 5px 0;"> ROPE AND REEVING MAX LIFT IN POUNDS </div> <div style="text-align: center;">  <p>6,450 PART IV</p> </div>	<p>⚠ CAUTION WIRE ROPE</p> <p>Keep at least 3 wraps of loadline of drum at all times</p> <p>Use only 5/16" diameter wire rope on this machine. Minimum breaking strength 9,520 lbs</p>
---	---

09HQ86050-URW295CUR

Sticker [TURNOVER PREVENTION DEVICE]

⚠ TURNOVER PREVENTION DEVICE (ZERO-ADJUSTMENT)

- Turnover prevention device is installed under a battery cover.
- Make sure outriggers are stored properly.
- Push the button, "ZERO RESET" and hold it for 1 second. When Zero-adjustment is completed properly, all indicators should be lighted up and the buzzer sound should be stopped for 2 seconds.
- Check the condition of outriggers and push the button again if the error happens. If it happens again despite doing the above procedure, please contact our service factories.

CONDITION OF CRANE AND TURNOVER PREVENTION DEVICE

INDICATORS (colour)	NORMAL CONDITION	ABNORMALCONDITION
RUN (green)	Lighting	Extinction
ERR (red)	Extinction	<ul style="list-style-type: none"> ■ Load cell error: Quick blink ■ CPU error: Extinction
ch. A-D (orange)	<ul style="list-style-type: none"> ■ Safe operation: Lighting / Slow blink ■ Turnover prediction: 2 blinks each time ■ Warning of turnover limit: Quick blink 	<ul style="list-style-type: none"> ■ Abnormal channels: Quick blink ■ Other channels: Lighting ■ CPU error: Extinction

(If the indicator shows a light other than above, refer to "Operation & Maintenance Manual.")

09HP81120-W095CDE

Sticker [TURNOVER PREVENTION DEVICE]

⚠ CAUTION TURNOVER PREVENTION DEVICE

- Be sure to perform inspection (pre-start inspection) before starting operations to make sure that this device works.
- Overload is strictly prohibited. This device is designed for operations within the rated load in principle and not for prevention of overload. Do not have too much confidence in this device. If the crane inclines due to swing of load or grounding on rough terrain, it could turnover.
- As ground reaction force is lowering, a warning indicating that turnover is close is given. Slow down the operating speed and immediately operate the crane to a safe side. If ground reaction force further lowers, the following crane movements stop automatically. In this case, extreme care must be used because the crane may turnover due to swing of load if the crane speed is fast.

Hoisting of hook
 Extension of boom
 Lowering of boom
 Swing to right and left

B-523959-W295C

Sticker [Safe loading & unloading of the carrier/travelling on inclines]



Safe loading & unloading of the carrier/travelling on inclines

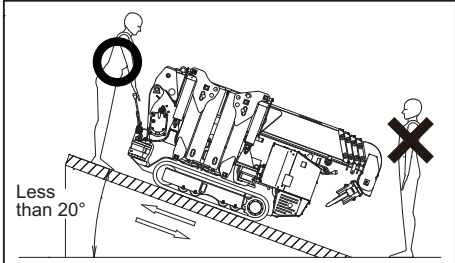

- Always ensure that the gradient of the ramp or surface is not greater than 20 degrees and has sufficient grip.
- Ensure that the ramp or surface will support the total weight of the crane and the operator.
- Scaffold boards or other materials not designed for use as ramps must not be used.
- Ensure that all other persons are kept clear from the carrier during travel.
- The operator must always drive the carrier from the uppermost position on the incline, i.e. reverse up the incline and follow the carrier down the incline.
- Never attempt to turn the carrier on an incline, always drive straight up and down.
- The carrier must always be manoeuvred slowly during travel up and down inclines.
- In the event that control of the carrier is lost during loading/unloading, do not attempt to step the carrier from falling.

30CF81050-W245CP2A

Sticker [Traveling on inclines - safety information]

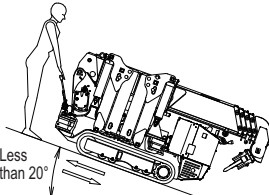
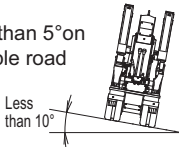
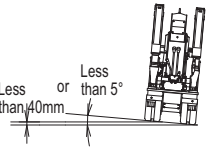

Running precautions

<p>Move forwards and backwards(straight)</p> <p>Always operate at the upper side of the carrier</p> 	<p>Left/right gradients</p> <p>Less than 5° on a stable road</p> 	<p>Slope of step(lateral)</p> <p>Less than 40mm or less than 5°</p> 
<ul style="list-style-type: none"> ■ Travel at low speeds near the shoulder of roads and on hills, and avoid abrupt starts and stops as well as sharp turns as it may cause the carrier to slip. ■ On a slope of a step, the carrier may roll over due to recoil so operate it as shown in the illustration and at a very low speed. 		
<p>30CF81030-W245CP2A</p>		

Sticker [Rated load table for extension jib] (URW295CP1UR series only)

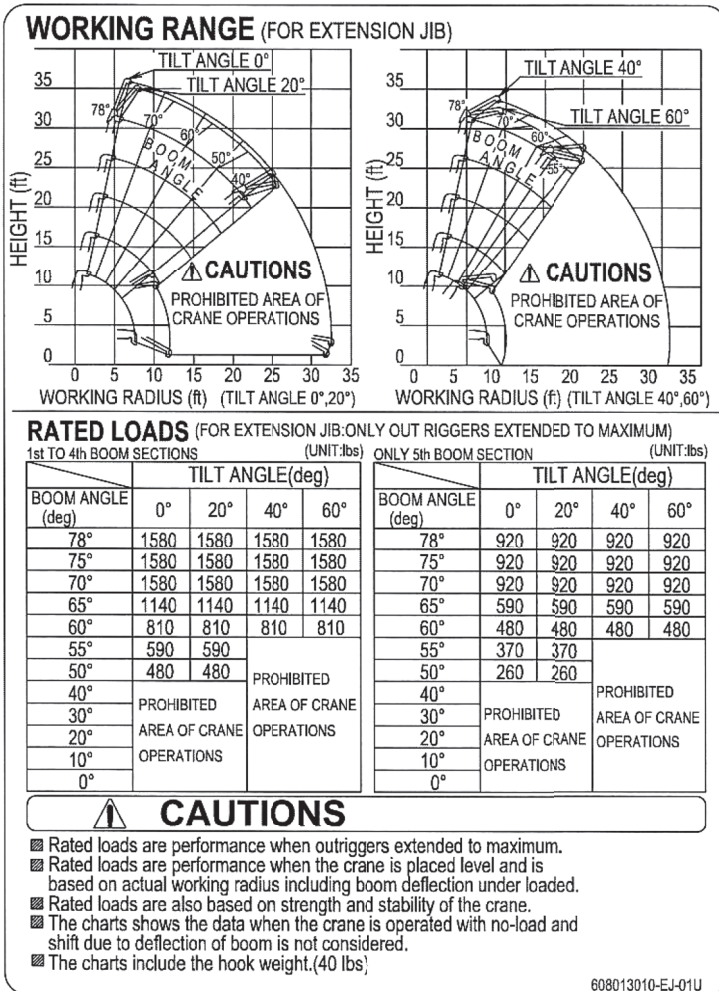

Sticker [Rated load table for searcher hook] (URW295CP1UR series only)

RATED LOADS (FOR SEARCHER HOOK)

1st TO 4th BOOM SECTIONS

WORKING RADIUS(ft)	RATED LOAD(lbs)	
	OUTRIGGERS MAX EXT	OUTRIGGERS NOT MAX EXT
12.5	1560	560
13.0	1560	460
15.0	1060	330
16.0	940	280
18.0	740	190
20.0	570	120
21.0	520	110
23.0	410	PROHIBITED AREA OF CRANE OPERATIONS
26.0	310	
27.5	240	

ONLY 5th BOOM SECTION

WORKING RADIUS(ft)	RATED LOAD(lbs)	
	OUTRIGGERS MAX EXT	OUTRIGGERS NOT MAX EXT
12.5	1120	560
13.0	1010	460
15.0	870	330
16.0	740	280
18.0	670	190
20.0	570	120
21.0	510	110
23.0	410	PROHIBITED AREA OF CRANE OPERATIONS
26.0	310	
30.0	220	
32.5	130	



CAUTIONS

- Rated loads are performance when the crane is placed level and is based on an actual working radius including boom deflection under loaded.
- Rated loads are also based on strength and stability of the crane.
- Rated loads must be reduced in accordance with wind, ground condition and operation speed.
- In order to make correct operation, read the instruction manual carefully before crane operation.
- The charts include the hook weight.(20 lbs)

608013020-EJ-01U

MEMO

A series of horizontal lines for writing. The first line is dashed, and the subsequent lines are solid. The lines are evenly spaced and extend across the width of the page.

7. DEFINITION OF TERMS

1 Extension and spread of outriggers

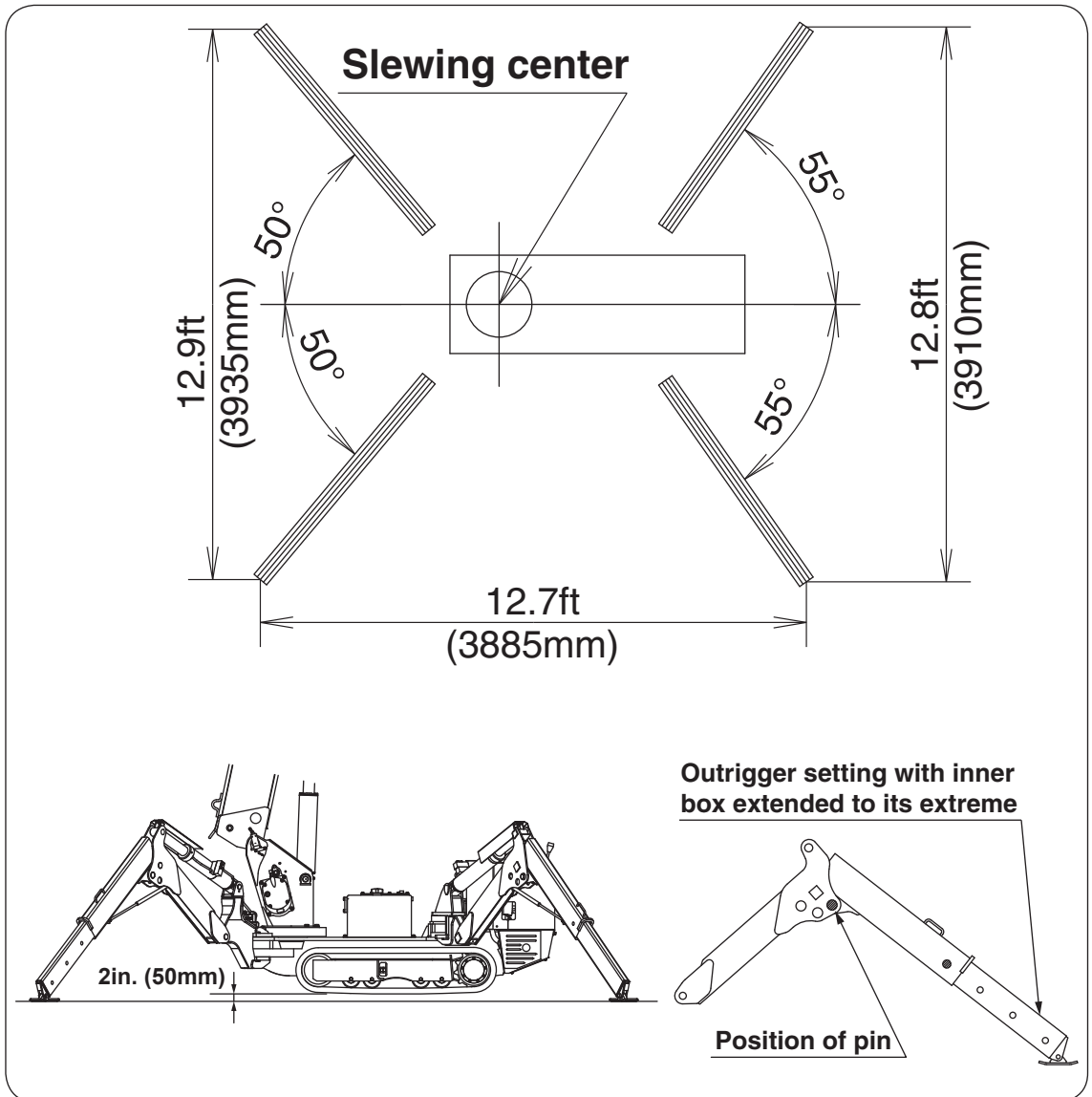

The figure above shows that outriggers are extended to maximum. Carry out operation by making the crane level on a flat and solid ground with the outriggers extended to maximum, and with the crane body raised by approx. 2in. (50mm) above the ground.

DEFINITION OF TERMS

- ◆ Rated load is expressed when the outriggers are extended to maximum and to a distance below maximum with their spread angle set the same.
As a rule, set the outriggers extended to their extremes and with the spread angle of each 55° and 50°.
When any one of 4 outriggers has not been set to the maximum extension, the rated load other than maximum extension is to be applied which must be observed.
- ◆ Since prohibited range of crane operation is specified according to spread angle of outriggers, confirm it on the sticker.
If it is failed to observe, the crane may be overturned.

Outriggers extended to maximum

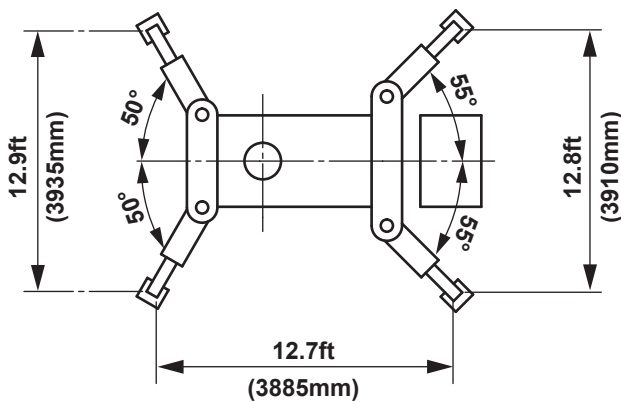

Outrigger setting with inner box extended to its maximum

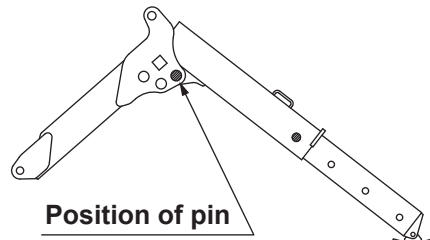

Example: Outrigger setting to a distance below maximum
(Figure shows they are set to minimum extension).

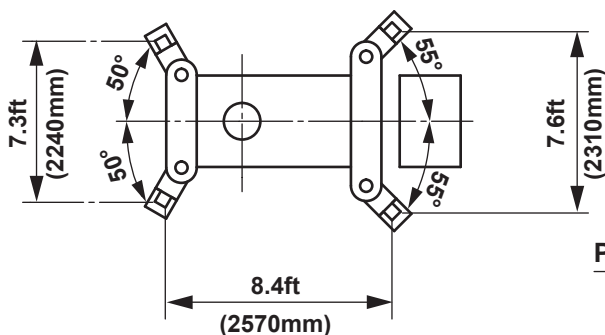

Outrigger setting with inner box pushed in to its minimum

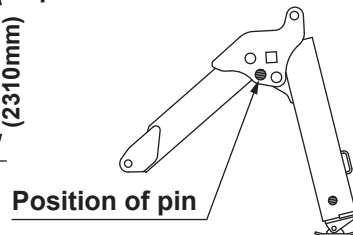

2 How boom-sections are extended

5-section boom

• How boom-sections are extended

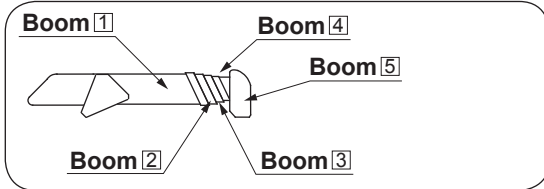

Boom 1
All boom sections are retracted.

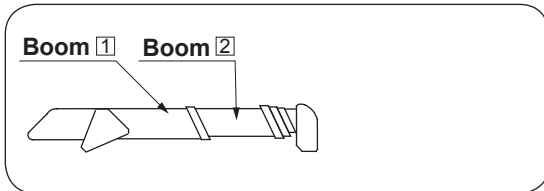

Boom 1+2 or 2
Boom section(2) only is extended.

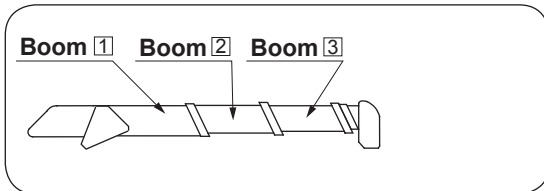

Boom 1+2+3 or 3
Boom sections(2) and (3) are extended.

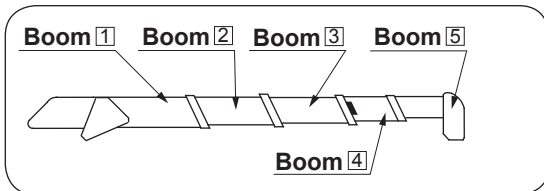

Boom 1+2+3+4 or 4
Boom section(4) is extended to the mark .

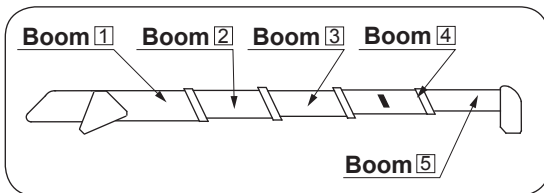

Boom 1+2+3+4+5 or 5
Boom-sections(2), (3), (4), and (5) are fully extended.

DEFINITION OF TERMS

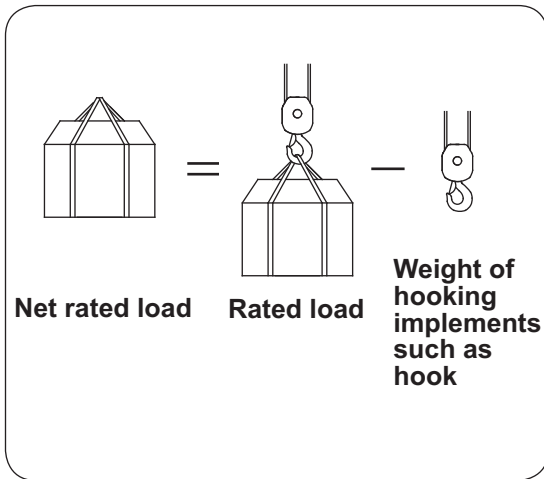

3 Net rated load

Net load which can be lifted by hook determined on the basis of stability of crane.

4 Rated load

Maximum load including hook and hooking implements which can be lifted according to the boom angle and/or the boom length determined on the basis of stability of crane.

5 Lifting capacity

This refers to maximum load of the rated load described section 4 above.

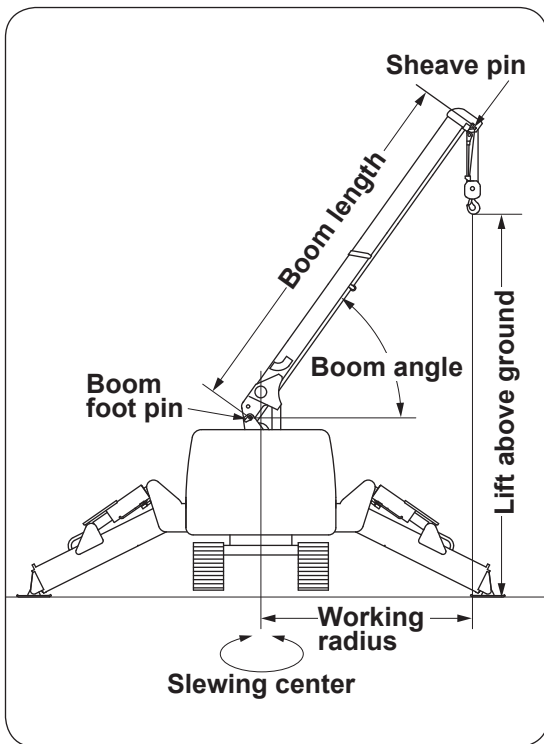

6 Working radius

This is horizontal distance from the slewing center to the hook center.

7 Boom length

This is distance from the boom foot pin to the sheave pin on the boom top.

8 Boom angle

This refers to an angle made by axis line of boom and the horizontal line.

9 Lift above ground

This refers to maximum vertical distance between bottom end of the hook to the ground surface with the hook wound up to touch the over-winding alarm detector.

8. HOW TO REFER TO WORKING RANGE CHART AND RATED LOAD CHART

These charts are stuck in front of crane operation levers and how to refer to charts is illustrated as follows:

1 Working range chart

The chart shows the relation among boom length and working radius, boom angle, and lift above ground.

■ URW295CPIUR

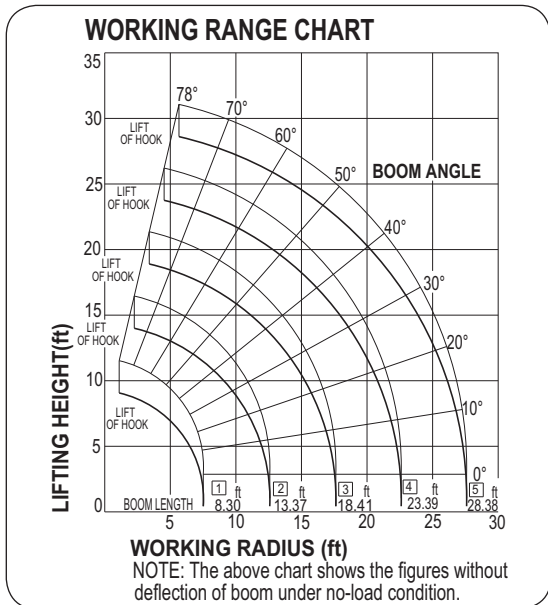

■ URW295SCPIUR

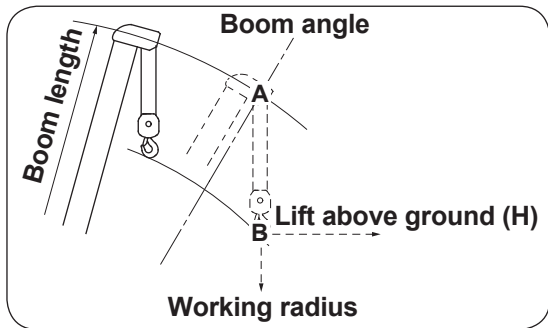
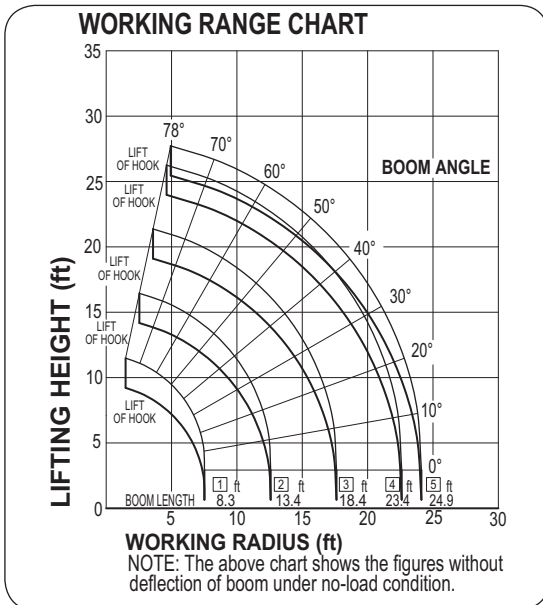

Although the point-A and the point-B follow the tracks along the same working radius, the point-A refers to the boom angle and the point-B the lift above ground.

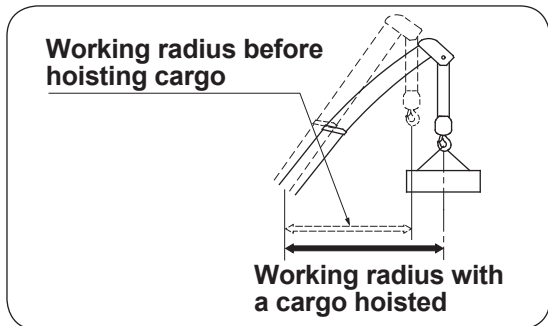

The working range chart does not incorporate any shift due to deflection of boom. Keep in mind that the actual working radius is somewhat extended due to boom deflection when a cargo is being hoisted.

HOW TO REFER TO WORKING RANGE CHART AND RATED LOAD CHART

2 Rated load chart

The chart shows maximum load which can be hoisted up for every combination of boom-sections to be extended for each working radius.

■ URW295CP1UR

RATED LOADS

BOOM SECTION		1 • 1+2								
WORKING RADIUS(ft)		3.0	4.5	5.0	6.0	7.0	8.0	10.0	11.0	12.58
RATED LOAD (lbs)	MAX EXT. OUTRIGGERS	6450	6450	5850	4950	4350	3800	2850	2450	2000
	NOT MAX EXT. OUTRIGGERS	4450	4450	4450	3150	2250	1600	1100	950	600

BOOM SECTION		1+2+3								
WORKING RADIUS(ft)		7.0	8.0	9.5	10.0	11.0	12.0	14.0	15.0	17.62
RATED LOAD (lbs)	MAX EXT. OUTRIGGERS	3050	3050	3050	2750	2450	2150	1650	1450	1000
	NOT MAX EXT. OUTRIGGERS	1850	1550	1250	1150	1000	850	600	550	300

BOOM SECTION		1+2+3+4								
WORKING RADIUS(ft)		11.0	12.5	13.0	15.0	16.0	17.0	18.0	20.0	22.61
RATED LOAD (lbs)	MAX EXT. OUTRIGGERS	1950	1950	1750	1350	1200	1100	1000	850	660
	NOT MAX EXT. OUTRIGGERS	1000	800	750	600	510	450	370	280	200

BOOM SECTION		1+2+3+4+5									
WORKING RADIUS(ft)		12.5	13.5	15.0	16.0	18.0	19.0	21.0	23.0	25.0	27.59
RATED LOAD (lbs)	MAX EXT. OUTRIGGERS	1280	1280	1050	920	750	700	590	500	440	350
	NOT MAX EXT. OUTRIGGERS	850	700	600	530	420	380	300	220	180	130

■ URW295SCP1UR

RATED LOADS

BOOM SECTION		1 • 1+2									
WORKING RADIUS (ft)		3.0	4.5	5.0	6.0	7.0	7.4	8.0	10.0	11.0	12.58
RATED LOAD (lbs.)	MAX EXT. OUTRIGGERS	1990	1990	1990	1990	1990	1990	1990	1990	1990	1990
	NOT MAX EXT. OUTRIGGERS	1990	1990	1990	1990	1990	1990	1600	1100	950	600

BOOM SECTION		1+2+3									
WORKING RADIUS (ft)		7.0	8.0	9.5	10.0	11.0	12.0	12.5	14.0	15.0	17.62
RATED LOAD (lbs.)	MAX EXT. OUTRIGGERS	1990	1990	1990	1990	1990	1990	1990	1650	1450	1000
	NOT MAX EXT. OUTRIGGERS	1850	1550	1250	1150	1000	850	780	600	550	300

BOOM SECTION		1+2+3+4								
WORKING RADIUS (ft)		11.0	12.5	13.0	15.0	16.0	17.0	18.0	20.0	22.61
RATED LOAD (lbs.)	MAX EXT. OUTRIGGERS	1950	1950	1750	1350	1200	1100	1000	850	660
	NOT MAX EXT. OUTRIGGERS	1000	800	750	600	510	450	370	280	200

BOOM SECTION		1+2+3+4+5								
WORKING RADIUS (ft)		12.5	13.5	15.0	16.0	18.0	19.0	21.0	23.0	24.1
RATED LOAD (lbs.)	MAX EXT. OUTRIGGERS	1280	1280	1050	920	750	700	590	500	460
	NOT MAX EXT. OUTRIGGERS	850	700	600	530	420	380	300	220	200



CAUTION

★ The chart shows hoisting capacity when the crane is set up level with the outriggers extended and the data are based on actual working radius by incorporating shift due to deflection of the boom under loaded.

★ The rated loads specified above are based on strength of the crane and stability of the crawler.

Be sure to check the rated load as it is to be changed according to how far the outriggers are extended.

★ This chart shows the rated load including load handling equipment such as slings, buckets, hook blocks, etc. and the weight of material being handled. The weight of the load handling equipment must be deducted from rated load rating to determine how much payload you can lift.

MEMO

A series of horizontal lines for writing. The first line is a dotted line, and the subsequent lines are solid. The lines are evenly spaced and extend across the width of the page.

9. DESCRIPTION OF EACH CONTROL DEVICE

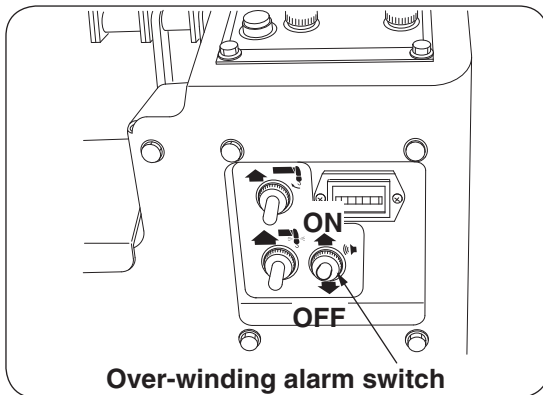
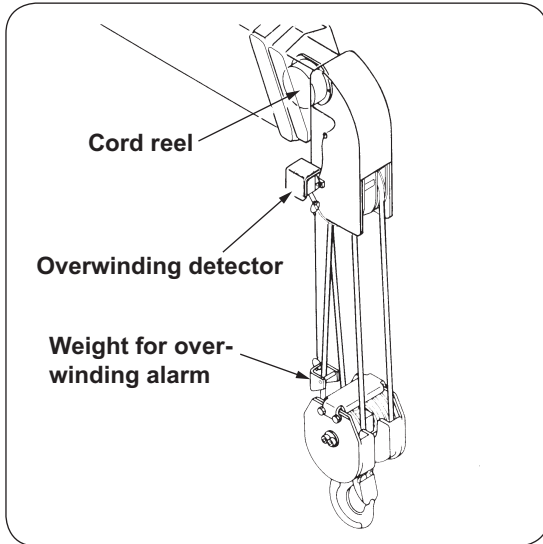

1 Overwinding alarm

◆1. Function of overwinding alarm

The device automatically makes an alarm sound to warn that the wire ropes are being over-wound when the hook comes close to the boom top.

◆2. Operating procedures

1 Turn ON the over-winding alarm switch before starting crane operation.

If the alarm sounds while the hook is being hoisted or the boom is being extended, stop the crane operation immediately and lower the hook or retract the boom.

2 Turn the alarm switch OFF after the crane work has been completed.

⚠ CAUTION

★ When the over-winding alarm switch is turned OFF, over-winding alarm will not function even if the hook is being overwound.

Be sure to turn the switch ON before starting crane work and check that the alarm sounds every time when the weight for over-winding alarm is lifted up to the detector.

★ Since the length of wire rope hanging the weight is specified by laws and regulations concerned, do not make it short at random.

★ The alarm sounds even if any of electric wires connected to the over-winding detector at the boom top is broken.

Ask an authorized UNIC service station for repair.

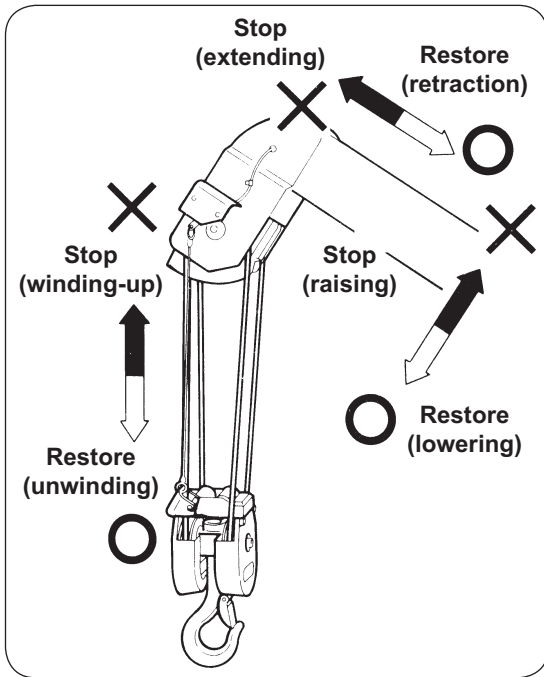

2 Automatic stop for overwinding

◆1. Function of automatic stop for overwinding

If the hook comes close to the boom top and it hits against the weight for over-winding alarm, buzzer sounds and functions of winding-up hook, extending boom, and raising boom stop automatically.

When the automatic stop is activated, lower the hook, retract or lower the boom until the buzzer stops sounding.

This allows the activated automatic stop to return to normal.

● Remarks

Since viscosity of hydraulic oil increases during cold winter or in low temperature environment, function of winding-up hook or extending boom may not stop perfectly but it allows to make a slight movement even if the hook hits against the weight which is not a disorder.

Carry out warming-up and the automatic stop recovers functioning when temperature of hydraulic oil rises to a certain level.

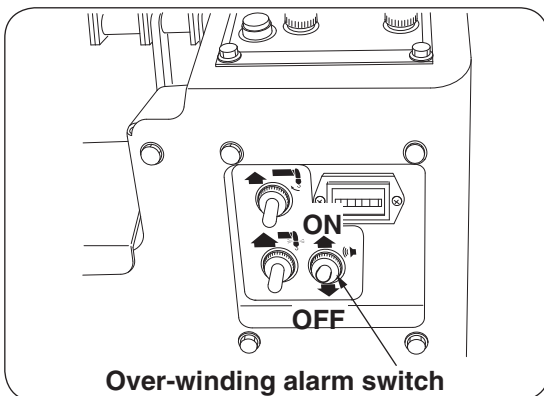

◆2. How to reset when automatic stop for over-winding is found out of order

If crane can not be operated due to failure in the automatic stop, reset the automatic stop and store the crane.

● Step 1

Turn the reset switch for the automatic stop to "Reset" to reset the automatic stop.

Then wind up the hook, extend or raise the boom by controlling operation lever.

■ URW295CP1UR

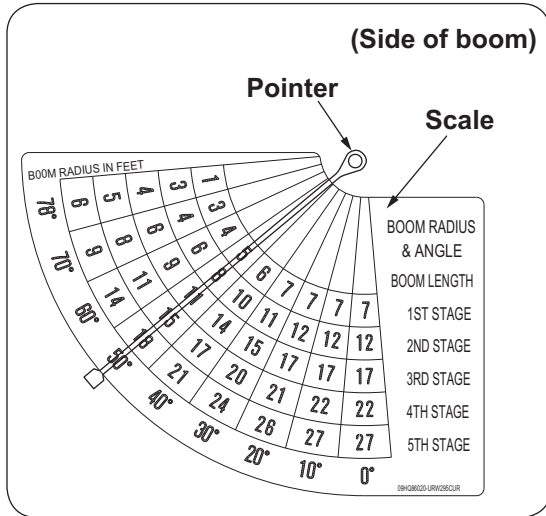

3 Boom angle chart

The chart reads the working radius corresponding to extended length of boom and its angle.

◆ **1. Working radius**

The value to which the needle points on the scale of meter is the working radius in each combination of boom-sections being extended.

◆ **2. Boom angle**

Deflection of the needle on the angle scale reads the boom angle.

■ URW295SCP1UR

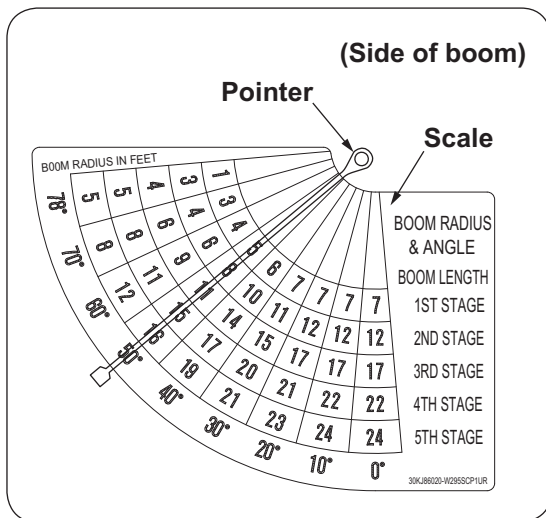

CAUTION

★ Use a proper scale band according to boom-sections being extended.

DESCRIPTION OF EACH CONTROL DEVICE

■ The following is an example of URW295CP1UR how to use the load chart.

1. Extend boom [4] completely.
2. Using the boom angle indicator as you guide, raise boom to 50° elevation. As can be seen, the boom radius is approximately 15 feet and the hook height is approximately 18 feet. By looking at the load chart, the boom capacity is 1350 lbs. When outriggers are extended fully. The capacity is 600 lbs when outriggers are not extended fully. This capacity must be reduced for some optional equipment.

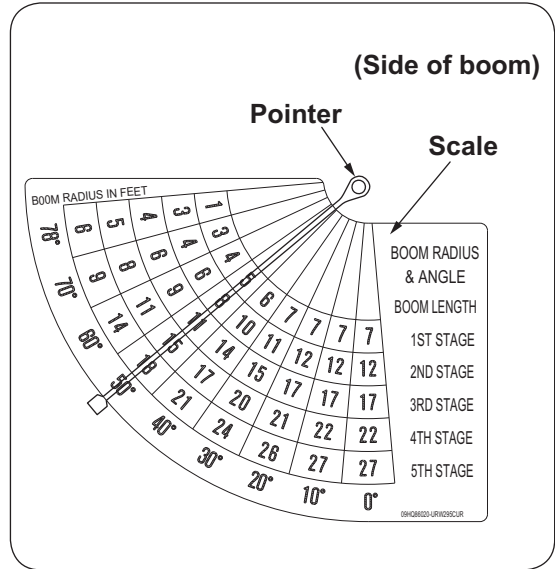
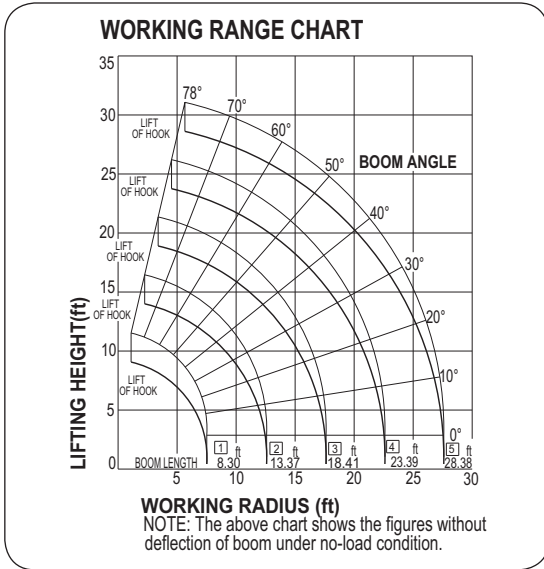

RATED LOADS

BOOM SECTION		1 • 1+2									
WORKING RADIUS(ft)		3.0	4.5	5.0	6.0	7.0	8.0	10.0	11.0	12.58	
RATED LOAD (lbs)	MAX EXT. OUTRIGGERS	6450	6450	5850	4950	4350	3800	2850	2450	2000	
	NOT MAX EXT. OUTRIGGERS	4450	4450	4450	3150	2250	1600	1100	950	600	

BOOM SECTION		1+2+3									
WORKING RADIUS(ft)		7.0	8.0	9.5	10.0	11.0	12.0	14.0	15.0	17.62	
RATED LOAD (lbs)	MAX EXT. OUTRIGGERS	3050	3050	3050	2750	2450	2150	1650	1450	1000	
	NOT MAX EXT. OUTRIGGERS	1850	1550	1250	1150	1000	850	600	550	300	

BOOM SECTION		1+2+3+4									
WORKING RADIUS(ft)		11.0	12.5	13.0	15.0	16.0	17.0	18.0	20.0	22.61	
RATED LOAD (lbs)	MAX EXT. OUTRIGGERS	1950	1950	1750	1350	1200	1100	1000	850	660	
	NOT MAX EXT. OUTRIGGERS	1000	800	750	600	510	450	370	280	200	

BOOM SECTION		1+2+3+4+5									
WORKING RADIUS(ft)		12.5	13.5	15.0	16.0	18.0	19.0	21.0	23.0	25.0	27.59
RATED LOAD (lbs)	MAX EXT. OUTRIGGERS	1280	1280	1050	920	750	700	590	500	440	350
	NOT MAX EXT. OUTRIGGERS	850	700	600	530	420	380	300	220	180	130

CAUTION RATED LOADS

- The rated loads show the performance of the crane on level ground and are based on the actual working radiuses including the deflection of boom under load condition. The rated loads are also based on strength and stability of crane.
- "Max extended outriggers" means inner boxes are extended to the max. extended position and a swing lock pin of each outrigger arm is inserted into the normal position. Other than the above, operate according to figures of "not max ext. outriggers"
- If even one outriggers are not fully extended, operate according to the figures of "not max. ext. outriggers".
- Improper set-up of outriggers may cause a turn over of the crane. Extend outriggers fully and Place them on firm and level ground. Make sure lock pins are inserted properly.
- Boom [1+2+3+4] means boom [4] is extended up to ▼ mark.
- Operate according to the figures of [1+2+3] when boom [3] is extended even a bit. Do according to [1+2+3+4] when boom [4] is extended even a bit. Do according to [1+2+3+4+5] when ▼ mark in the side of boom [4] moves away from boom [3] even a bit.

09HQ86040-W295CUR

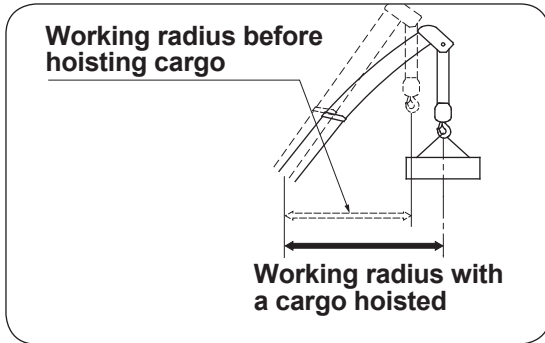

CAUTION

★ When a boom is extended to halfway, use the rated load with the boom concerned fully extended in order to secure safety.

- When boom-section **3** is extended from boom-section **2**, take the rated load for boom **1+2+3** (2450 lbs in the example of URW295CP1UR shown above).

- When boom - section **4** is extended from boom-section **3**, take the rated load for boom **1+2+3+4** (1350 lbs in the example of URW295CP1UR shown above).

★ Since the working radius increases due to deflection of the boom when a cargo starts to be lifted up, set the boom angle so that the hook comes to somewhat inner side.

DESCRIPTION OF EACH CONTROL DEVICE

■ The following is an example of URW295SCP1UR how to use the load chart.

1. Extend boom [4] completely.
2. Using the boom angle indicator as you guide, raise boom to 50° elevation. As can be seen, the boom radius is approximately 15 feet and the hook height is approximately 18 feet. By looking at the load chart, the boom capacity is 1350 lbs. When outriggers are extended fully. The capacity is 600 lbs when outriggers are not extended fully. This capacity must be reduced for some optional equipment.

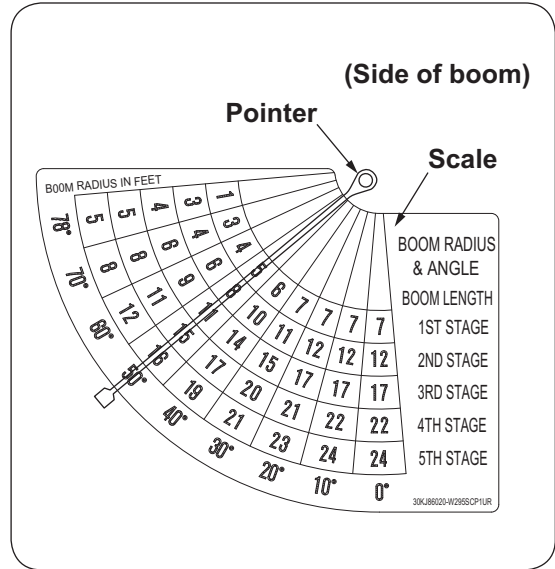
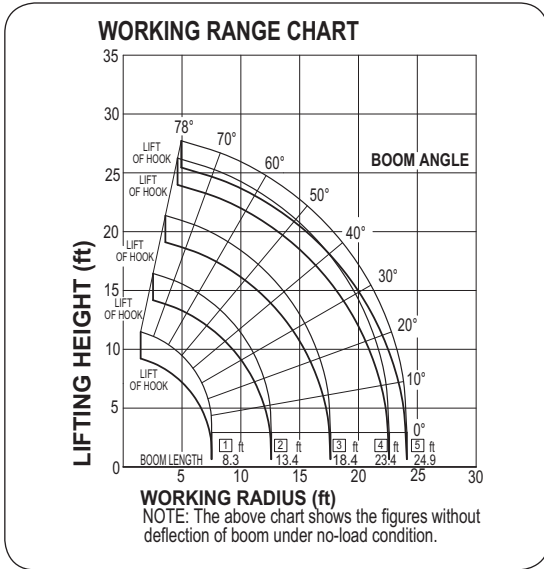

RATED LOADS

BOOM SECTION	1 • 1+2									
WORKING RADIUS(ft)	3.0	4.0	5.0	6.0	7.0	7.4	8.0	10.0	11.0	12.58
RATED LOAD (lbs)	MAX EXT. OUTRIGGERS	1990	1990	1990	1990	1990	1990	1990	1990	1990
	NOT MAX EXT. OUTRIGGERS	1990	1990	1990	1990	1990	1600	1100	950	600

BOOM SECTION	1+2+3									
WORKING RADIUS(ft)	7.0	8.0	9.5	10.0	11.0	12.0	12.5	14.0	15.0	17.62
RATED LOAD (lbs)	MAX EXT. OUTRIGGERS	1990	1990	1990	1990	1990	1990	1650	1450	1000
	NOT MAX EXT. OUTRIGGERS	1850	1550	1250	1150	1000	850	780	600	300

BOOM SECTION	1+2+3+4									
WORKING RADIUS(ft)	11.0	12.5	13.0	15.0	16.0	17.0	18.0	20.0	22.61	
RATED LOAD (lbs)	MAX EXT. OUTRIGGERS	1950	1950	1750	1350	1200	1100	1000	850	660
	NOT MAX EXT. OUTRIGGERS	1000	800	750	600	510	450	370	280	200

BOOM SECTION	1+2+3+4+5									
WORKING RADIUS(ft)	12.5	13.5	15.0	16.0	18.0	19.0	21.0	23.0	24.1	
RATED LOAD (lbs)	MAX EXT. OUTRIGGERS	1280	1280	1050	920	750	700	590	500	460
	NOT MAX EXT. OUTRIGGERS	850	700	600	530	420	380	300	220	200

⚠ CAUTION RATED LOADS

- The rated loads show the performance of the crane on level ground and are based on the actual working radiuses including the deflection of boom under load condition. The rated loads are also based on strength and stability of crane.
- "Max. extended outriggers" means inner boxes are extended to the max. extended position and a swing lock pin of each outrigger arm is inserted into the normal position. Other than the above, operate according to figures of "not max. ext. outriggers".
- If even one outriggers are not fully extended, operate according to the figures of "not max. ext. outriggers".
- Improper set-up of outriggers may cause a turn over of the crane. Extend outriggers fully and place them on firm and level ground. Make sure lock pins are inserted properly.
- Boom [1+2+3+4] means boom [4] is extended up to ▼ mark.
- Operate according to the figures of [1+2+3] when boom [3] is extended even a bit. Do according to [1+2+3+4] when boom [4] is extended even a bit. Do according to [1+2+3+4+5] when ▼ mark in the side of boom [4] moves away from boom [3] even a bit.

30KJ86040-W295SCP1UR

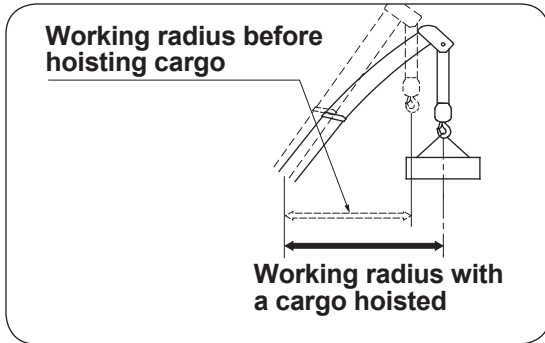

CAUTION

★ When a boom is extended to halfway, use the rated load with the boom concerned fully extended in order to secure safety.

- When boom-section **3** is extended from boom-section **2**, take the rated load for boom **1+2+3** (1990 lbs in the example of URW295SCP1UR shown above).

- When boom - section **4** is extended from boom-section **3**, take the rated load for boom **1+2+3+4** (1350 lbs in the example of URW295SCP1UR shown above).

★ Since the working radius increases due to deflection of the boom when a cargo starts to be lifted up, set the boom angle so that the hook comes to somewhat inner side.

DESCRIPTION OF EACH CONTROL DEVICE

- ◆ How to refer to hoisting capacity when outriggers are extended to minimum or to halfway.

As a general rule, the outriggers are to be extended to their extremes.

If it is forced to operate the crane with the outriggers extended to minimum or to halfway, operate the crane in accordance with instructions shown below.

■ URW295CP1UR

1. Find the working radius.
2. The rated load is to be obtained from the data shown in the "not max ext. outriggers" according to how boom-sections are extended.
 - When operated with the working radius of 11ft, with the extended boom configuration of **1+2**, and with outriggers extended to halfway or to minimum, take 950 lbs.
 - When operated with the working radius of 10ft, with the extended boom configuration of **1+2+3**, and with outriggers extended to halfway or to minimum, take 1150 lbs.

RATED LOADS

BOOM SECTION	1	•	1+2							
WORKING RADIUS(ft)	3.0	4.5	5.0	6.0	7.0	8.0	10.0	11.0	12.58	
RATED LOAD (lbs)	MAX EXT. OUTRIGGERS		6450	6450	5850	4950	4350	3800	2850	2000
	NOT MAX EXT. OUTRIGGERS		4450	4450	4450	3150	2250	1600	1100	950

BOOM SECTION	1+2+3									
WORKING RADIUS(ft)	7.0	8.0	9.5	10.0	11.0	12.0	14.0	15.0	17.62	
RATED LOAD (lbs)	MAX EXT. OUTRIGGERS		3050	3050	3050	2750	2450	2150	1650	1450
	NOT MAX EXT. OUTRIGGERS		1850	1550	1250	1150	1000	850	600	550

■ URW295SCP1UR

1. Find the working radius.
2. The rated load is to be obtained from the data shown in the "not max ext. outriggers" according to how boom-sections are extended.
 - When operated with the working radius of 11ft, with the extended boom configuration of **1+2**, and with outriggers extended to halfway or to minimum, take 950 lbs.
 - When operated with the working radius of 10ft, with the extended boom configuration of **1+2+3**, and with outriggers extended to halfway or to minimum, take 1150 lbs.

RATED LOADS

BOOM SECTION	1	•	1+2							
WORKING RADIUS(ft)	3.0	4.5	5.0	6.0	7.0	7.4	8.0	10.0	11.0	12.58
RATED LOAD (lbs)	MAX EXT. OUTRIGGERS		1990	1990	1990	1990	1990	1990	1990	1990
	NOT MAX EXT. OUTRIGGERS		1990	1990	1990	1990	1990	1600	1100	950

BOOM SECTION	1+2+3									
WORKING RADIUS(ft)	7.0	8.0	9.5	10.0	11.0	12.0	12.5	14.0	15.0	17.62
RATED LOAD (lbs)	MAX EXT. OUTRIGGERS		1990	1990	1990	1990	1990	1990	1650	1450
	NOT MAX EXT. OUTRIGGERS		1850	1550	1250	1150	1000	850	780	600



CAUTION

★ When the outriggers are extended to minimum or halfway, operate the crane according to capacity obtained from “not max extended outriggers” on the chart of rated load.



WARNING

★ It is important that you know the weight of any material that you attempt to handle.

This can be determined by use of a dynamometer or scales.

Note: The rated load chart shows the rated load including load handling equipment such as slings, buckets, hook block, etc., and the weight of material being handled.

The weight of load handling equipment must be deducted from the rated load rating to determine how much payload you can lift.

DESCRIPTION OF EACH CONTROL DEVICE

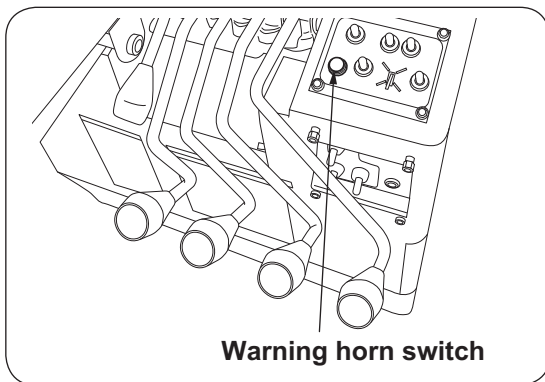
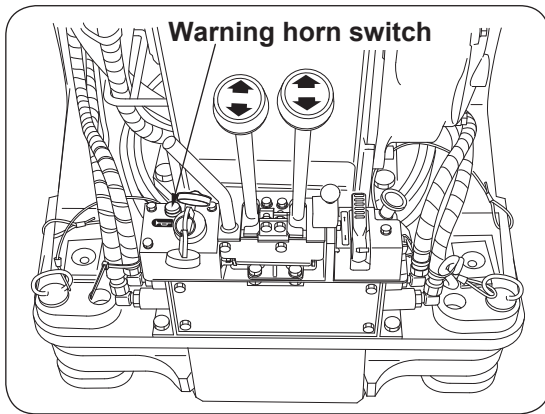

4 Warning horn

Before lifting up the cargo, depress the warning horn switch on the crawler panel to give warning sound to those who have entered within slewing range during crane operation, or to workers in charge of slinging work near the cargo or in a course where the cargo may pass along.

Depress the switch button to give warning sound.

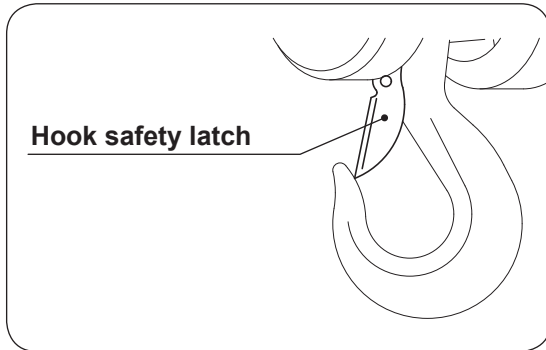

5 *Hook safety latch*

The mechanism is to prevent slinging wire rope from being disengaged out of the hook.

6 *Automatic stop for leaving minimum wire rope (With wire rope retaining roller)*

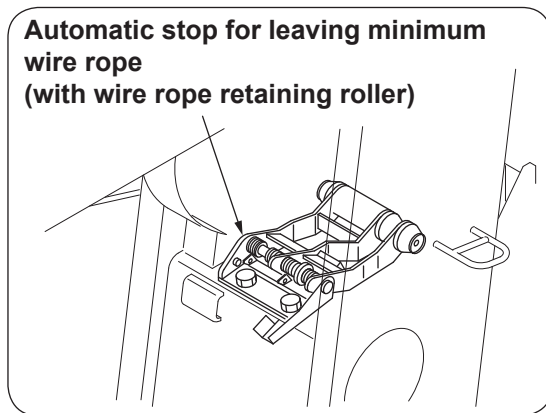

This is a device to restrict slackening of wire rope on the drum.

The device prevents the rope on the drum from slackening when winding up and down the hook or making it an abrupt stop and when the hook is lowered to the ground.

In addition, it allows to stop unwinding automatically when remaining wire ropes on the drum come close to 3 turns so that the rope can not be unwound further.

7 Specifications on turnover prevention device

WARNING

★ Observe the caution to secure safety.

Failure to observe the cautions may invite trouble or serious accident. Be sure to carry out the inspection in particular before starting operation.

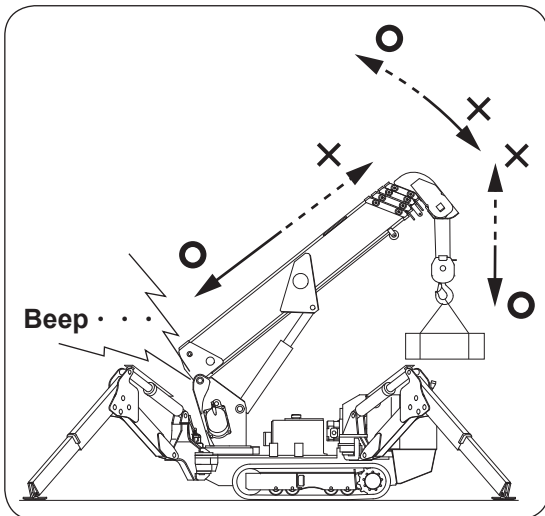

1 Carry out careful inspection before operation, and daily and periodical inspection to confirm that the turnover prevention device functions properly.

2 The turnover prevention device is a safety device that allows to slow down operating speed gradually while making an intermittent warning sound when the ground reaction against the outrigger located on opposite side of the boom decreases to the specified level due to increase of crane moment.

If the reaction force of the outrigger decreases further, the warning changes to continuous sound and the crane makes an automatic stop. Crane functions to be stopped are : winding up hook, extending boom, and lowering boom. Check the turnover prevention device for proper operation before starting the crane operation.

3 If the crane is operated via radio-controller, operate it within the range where the alarm sound can be heard.

4 Over-loaded operation is strictly prohibited.

The turnover prevention device is not a device for preventing overload.

It is the principle that you should persistently observe the operation within rated load.

Do not put too much confidence on the device.

Leaning of the crane due to swing of a lifted cargo or parking on unlevelled ground may allow the crane to be overturned.

DESCRIPTION OF EACH CONTROL DEVICE

5 If an alarm sounds intermittently due to decrease of ground reaction against outriggers, operating the crane to safer side.

If the reaction force of the outrigger decreases further, the crane makes an automatic stop. In this case, faster operating speed can make the crane to be overturned to which must pay attention.

6 Observe that the crane shall not be operated within the prohibited range in extending outriggers.

The turnover prevention device will not function safely when the crane is operated within the prohibited range.

7 Keep the "ON-OFF" switch for alarm buzzer turning ON unless there is any special reason.

8 As a rule, set up the crane on a flat and solid ground to operate it with the outriggers extended to their extremes, with the truck kept level, and with the rubber crawler lifted up by approx. 2in. (50mm) above the ground.

DESCRIPTION OF EACH CONTROL DEVICE

◆1. Construction of turnover prevention device

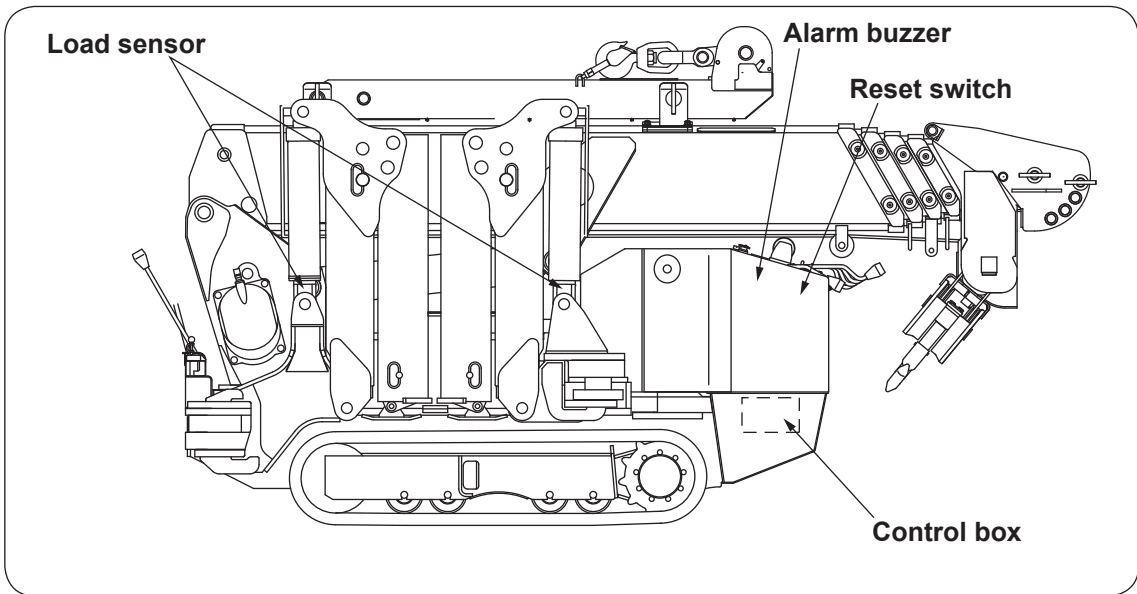

◆2. Inspection before starting crane operation

WARNING

★ Be sure to carry out inspection of turnover prevention device before starting the crane operation to check that the device functions normally. If found something wrong with the device, ask a UNIC authorized service shop for repair as soon as possible.

★ Turn "ON" the turnover prevention alarm buzzer switch while carrying out preparation of the crane operation to check that continuous alarm sound is heard until the outriggers are set up on the ground. If the alarm fails to sound, ask a UNIC authorized service shop for repair immediately as something is wrong with the turnover prevention device.

★ The crane might be overturned even if the system has been actuated when a lifted cargo is swinging and/or operation speed is too fast because the load is increased by inertia.

Do not rely too much on the system but try always carrying out safe operation of the crane carefully by observing that the load is kept within the rated load.

DESCRIPTION OF EACH CONTROL DEVICE

Check the following before starting crane operation.

If found something wrong with the turnover prevention device, contact with a UNIC authorized service shop as soon as possible because it will not function as a safety device.

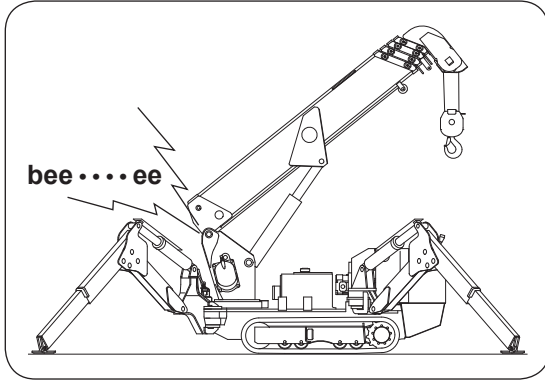

1 Check that the continuous alarm sound (bee...ee) of the turnover prevention device is issued before setting up outriggers. (Keep always the "ON-OFF" switch for alarm buzzer turning ON.)

2 By following procedures for setting up the outriggers on the ground, rotate the outriggers to secure them with the lock pins at this time, allow the outriggers to be fully retracted without setting them up on the ground.

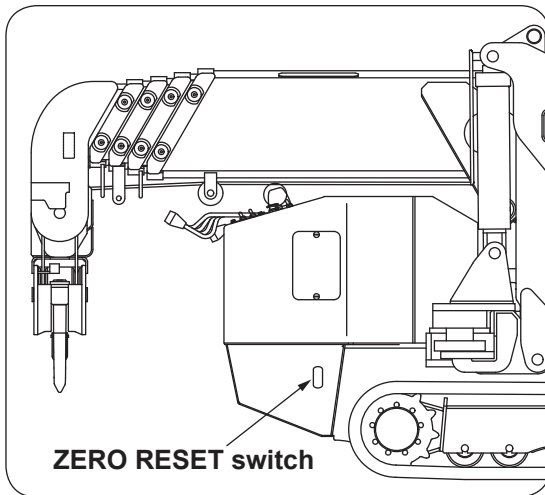

3 Through the hole on the side of operation panel, depress the "ZERO RESET" switch in the control box of turnover prevention device mounted inside for 1 second.

★ When the zero-point adjustment has successfully been completed, all the lamps for self-diagnosis light for 2 seconds and the overturn alarm buzzer will stop sounding for 2 seconds.

After that, "RUN" lamp (green) lights and lamps of "ch. A" through "ch. D" blink.

★ In addition, the overturn alarm buzzer makes a continuous sound.

4 Confirm that the alarm buzzer stops sounding when the outriggers have been set up on a solid and level ground.

(Set them up so that the crane body can be positioned at 2in.(50mm) off the ground.) Check at this time that lamps of "RUN" and "ch. A" through "ch. D" among the self-diagnosis lamps in the control box of turnover prevention device lights or blinks.

DESCRIPTION OF EACH CONTROL DEVICE

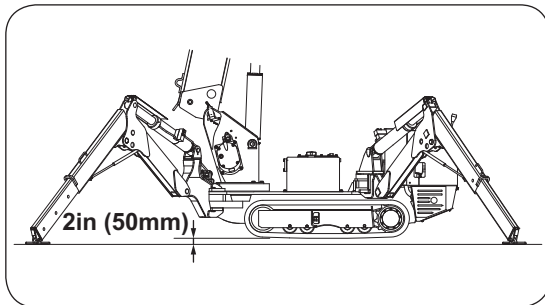
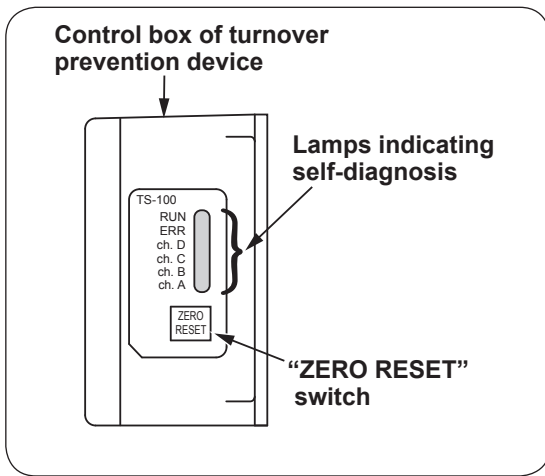

5 After the outriggers have been set up properly and the buzzer is making no alarm sound, check that the alarm buzzer starts to make an intermittent sound (beep, beep) when the two adjacent outriggers are retracted gradually.

6 Check also that the alarm buzzer makes a continuous sound (bee····ee) when the two adjacent outriggers are retracted further.

7 In the condition that the alarm buzzer is making a continuous sound (bee····ee), following crane operation will become impossible:

- Extension of boom
- Lowering boom
- Winding-up hook
- Slewing boom



CAUTION

★ Do not carry out “zero point adjustment” for turnover prevention device after the outriggers have been set up.

Depression of “ZERO RESET” switch in this condition, the “zero point adjustment” does not complete successfully which in turn the turnover prevention device will be in failure so that crane operation of winding-up hook, extension of boom, lowering boom, and slewing boom cannot be possible.

In this case, store the crane by following the step 1 illustrated on page 9-19, “How to release when turnover prevention device” is found to be out of order, then store the outriggers to depress the “ZERO RESET” switch again.

★ Although in case where the “zero point adjustment” has been completed, the “RUN” lamp fails to be lit, or if lamps of “ch. A” through “ch. D” are blinking even after the outriggers have been set up right, ask a UNIC authorized service shop immediately for inspection and repair as the reaction force detector may be out of order.

★ After the “zero point adjustment” has been completed right, if the “ERR” lamp blinks for only 5 seconds and the alarm buzzer makes an intermittent sound (Beep, Beep) at the same time when the “RUN” lamp lights, it indicates that the reaction force detector should be replaced. Although the reaction force detector can be used for some time, ask a UNIC authorized service shop as early as possible for repair.

★ In case where the “ERR” lamp in the control box of turnover prevention device is blinking, the alarm buzzer makes a brief intermittent sound (Pi, Pi, Pi •••).

Since this indicates that the turnover prevention device is in trouble, ask a UNIC authorized service shop immediately for inspection and repair.

DESCRIPTION OF EACH CONTROL DEVICE

◆3. Function of turnover prevention device

Carry out normal crane operation after completion of inspection before starting crane operation. The turnover prevention device is a safety device that prevents the crane from being overturned by stopping crane functions automatically while issuing alarm sound when the average setting-up reaction force of the ground against two (2) adjacent outriggers on the opposite side of the boom reaches the specified set value.

The setting-up reaction force of the ground against each outrigger is always detected by load cell.

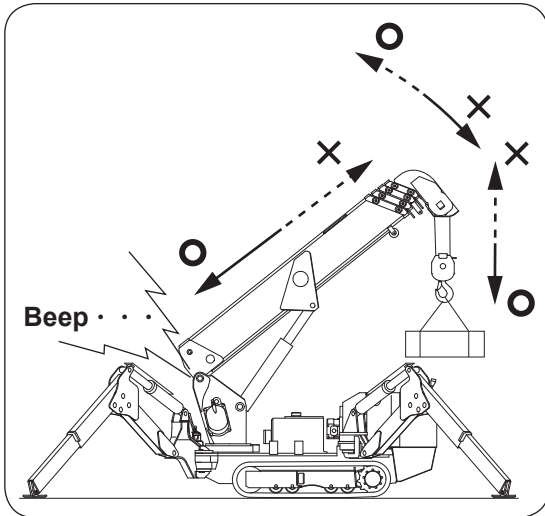

1 Advance alarm for overturn

When the average of setting-up reaction force of the ground against two (2) adjacent outriggers on the opposite side of the boom decreases, the alarm buzzer makes an intermittent alarm sound (beep, beep) of advance alarm to give a warning.

If the alarm is heard, slow down operation speed of the crane to operate it for safer side immediately.

2 Threshold alarm for overturn

When the average of setting-up reaction force of the ground against two (2) adjacent outriggers on the opposite side of the boom decreases further and it becomes dangerous conditions, the alarm buzzer makes an continuous threshold alarm sound (bee...ee) to give a warning and following functions of the crane are to be stopped automatically:

- Hoisting hook
- Extending boom
- Lowering boom
- Slewing boom

★ The crane may be overturned due to swing of a lifted cargo such as by an abrupt stop when the crane is operated in high speed to which special attention must be paid.

★ If sound of alarm buzzer should be avoided such as in working at night or working in residential areas, turn OFF the alarm buzzer switch to stop the buzzer.

Turn it ON when in normal crane operation.

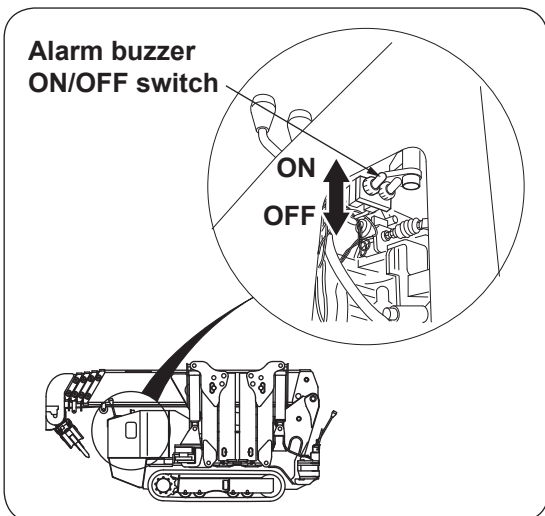

◆4. Self-diagnosis functions

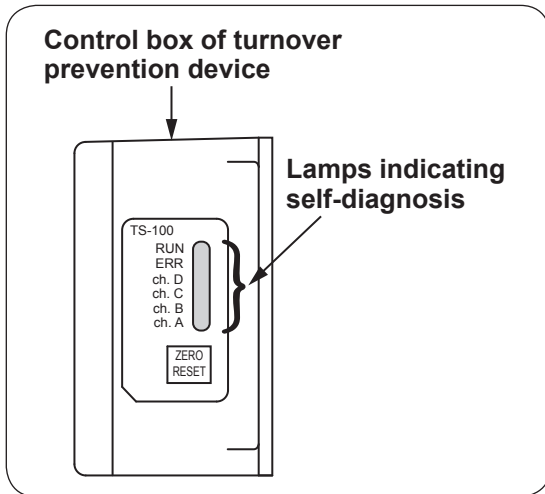

"Lamps indicating self-diagnosis" are mounted in the control box of turnover prevention device to show such as operation, detailed faults of the device.

"RUN" lamp (green)

It lights when the turnover prevention device is functioning right.

"ERR" lamp (red)

It lights when the reaction force detector is in trouble.

"ch. D" lamp (orange)

It lights or blinks according to outriggers on the rear-right side of the crane body.

"ch. C" lamp (orange)

It lights or blinks according to outriggers on the front-right side of the crane body.

"ch. B" lamp (orange)

It lights or blinks according to outriggers on the front-left side of the crane body.

"ch. A" lamp (orange)

It lights or blinks according to outriggers on the rear-left side of the crane body.

★ The lamps of "ch. A" through "ch. D" indicate condition of each outrigger separately how it touches the ground and the alarm of the turnover prevention device is to be determined by combination of two (2) adjacent outriggers with smaller reaction force against combination of outriggers than other combination.

★ All the self-diagnosis lamps light up for approximately 2 seconds after the crane traveling lever interlock has been switched to the crane.

Self-diagnosis for the turnover prevention device is being carried out while the lamps for self-diagnosis are being lit.

DESCRIPTION OF EACH CONTROL DEVICE

● Indication of lamps for self-diagnosis when turnover prevention device functions normally

Lamps	Indication	State
RUN	Lighting	Turnover prevention device is functioning right.
ERR	Lighting off	
ch.D ch.C ch.B ch.A	Quick blinking	It is in condition of overturn threshold as ground reaction force against outriggers has been decreased, or outriggers have been stored.
	2 blinking at a time	It is in condition of overturn prediction as ground reaction force against outriggers has been decreased.
	Lighting or slow blinking	Crane can be operated safely due to sufficient ground reaction force against outriggers.

● Indication of lamps for self-diagnosis when turnover prevention device is in trouble

◆ When reaction force detector is in trouble

Lamps	Indication	State
RUN	Lighting off	Reaction force detector is in trouble.
ERR	Quick blinking	
ch.D ch.C ch.B ch.A	Quick blinking	Reaction force detector is in trouble.
	Lighting	Reaction force detector is working right.

◆ When control box of turnover prevention device is in trouble All the lamps for self-diagnosis do not light.

CAUTION

In case where the crane cannot be operated because a trouble has been occurred to the turnover prevention device while the crane is being operated, turn OFF the engine key once then start the engine again.

If the trouble fails to be solved, store the crane by following the steps illustrated on page 9-18, "How to release when turnover prevention device" is found to be out of order, then ask a UNIC authorized service shop for repair.

◆5. How to release when turnover prevention device is found to be out of order

If the crane cannot be operated due to trouble in the turn over prevention device, store the crane in accordance with steps as follows:

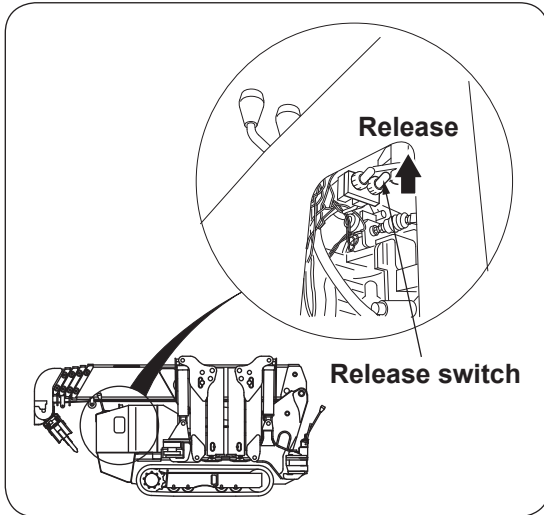

● Step 1

The release switch for turnover prevention device is located inside of the cover near the recoil of engine.

Operate the crane while the release switch is being pushed up.

If the crane is operated with the release switch pushed up, the device loses the functions as the safety device.

Operate the crane by paying special attention that the crane will not be overturned.

If any of outriggers is raised before the boom and the hook have been stored, the turnover prevention device is to be actuated so that the crane turns to be inoperable.

Store the crane while the release switch is being pushed up.

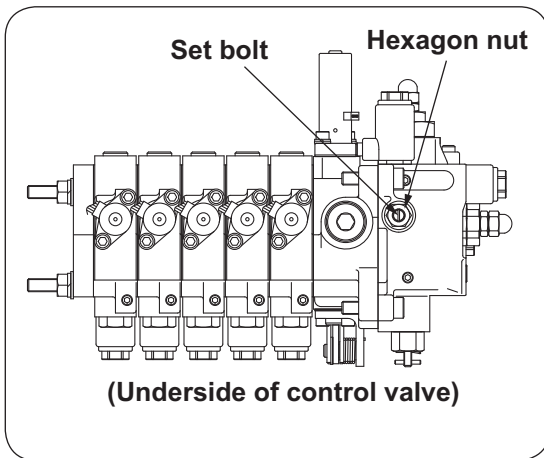

● Step 2

If the crane cannot be operated (it will not function) by taking measures in "step 1" above, operate the crane by following procedures below.

Unfasten the hexagon nut on the side of unload valve attached to underside of the control valves to tighten up the set bolt being locked until it comes to a stop.

Since this allows the crane to be operated, store the crane by controlling levers.

⚠ CAUTION

★ Since this is a temporary measures in an emergency, be sure to repair it at a UNIC service shop after the crane has been stored.

◆6. Caution plates in detail



- ★ Always keep the stickers clean so that they can be read easily.
- ★ If any of the stickers has come off, stick it again or replace it with new sticker.
- ★ When ordering stickers, specify the part number shown at the bottom-right of the sticker concerned.

 **CAUTIONS** TURNOVER PREVENTION DEVICE

- Be sure to perform inspection (pre-start inspection) before starting operations to make sure that this device works.
- Overload is strictly prohibited. This device is designed for operations within the rated load in principle and not for prevention of overload. Do not have too much confidence in this device. If the crane inclines due to swing of load or grounding on rough terrain, it could turnover.
- As ground reaction force is lowering, a warning indicating that turnover is close is given. Slow down the operating speed and immediately operate the crane to a safe side. If ground reaction force further lowers, the following crane movements stop automatically. In this case, extreme care must be used because the crane may turnover due to swing of load if the crane speed is fast.

○Hoisting of hook ○Extension of boom ○Lowering of boom ○Swing to right and left

10. HOW TO OPERATE CARRIER

1 Designation of each control lever and its location

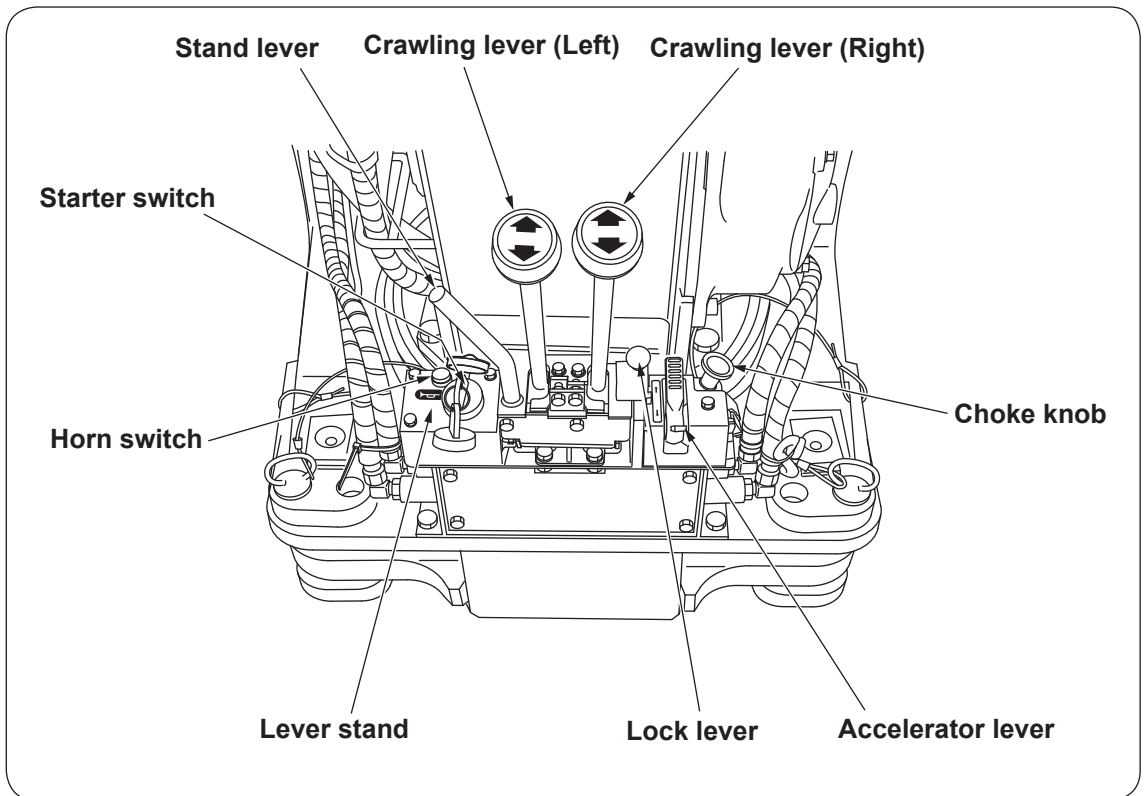

2 Preparation before operation

WARNING

- ★ Ventilate well when starting the engine in a small limited area or indoors.
- ★ Do not start the engine from the outside of the operator's position.
- ★ Confirm the safety around the crane working site before starting the engine.

CAUTION

- ★ Heavy-duty operation of the crane during an initial period after the start of operation may deteriorate its performance in a shorter time. Take approximately 100 hours after the start of operation as a breaking in period during which abrupt start and acceleration, and continuous operation under heavy load must be avoided.

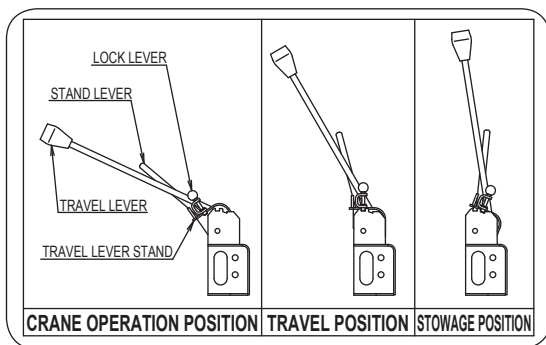

1 Shift the crawling lever stand to "Travel" position.

2 Make sure that both crawling levers (left and right) are at their neutral positions.

3 Confirm that the machine is at crawling posture.

- Boom is lowered to its extreme.
- Outriggers are stored.
- Hook is stored.

4 Open the fuel cock.

5 Raise engine speed to that somewhat higher than idling.

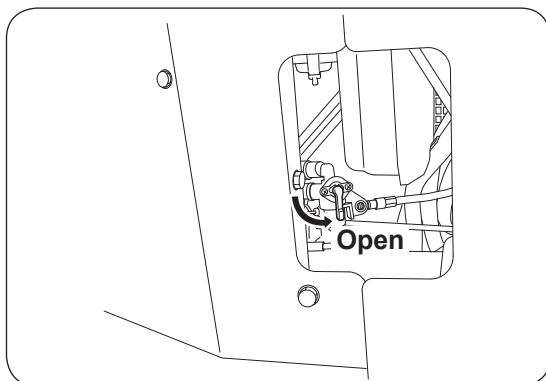

3 How to operate

! WARNING

- ★ Do not start the engine by using a auxiliary ignition fluid as it may be in danger of explosion.
- ★ Be sure to repair whenever found anything unusual.
- ★ Be sure to stop the engine before re-fueling.

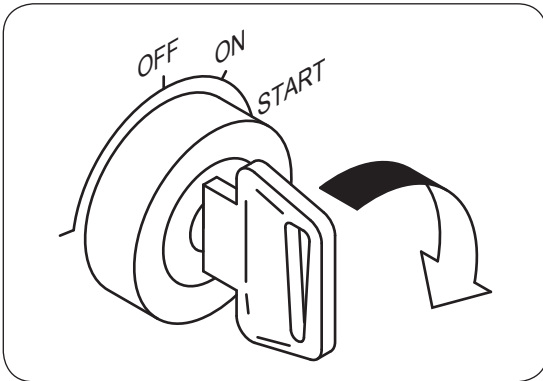

◆ 1. Starting engine

● Starting in normal condition

1 Insert the key into the starter switch and turn it to **ON** position.

2 Pull the accelerator lever a bit, and pull the choke knob if the engine is cold.

Return the choke knob fully to its original position after the engine has started.

3 Turn the switch key to **START** position to start the engine.

4 Release the key after the engine has started running.
The key returns to **ON** position by itself.

! CAUTION

- ★ Continuous running of starter motor allows the battery to be discharged and the starter motor itself to be damaged.
Do not activate the motor for more than 5 seconds without a break.
- ★ If the engine failed to be started, wait 1 or 2 minutes to try it again.

HOW TO OPERATE CARRIER

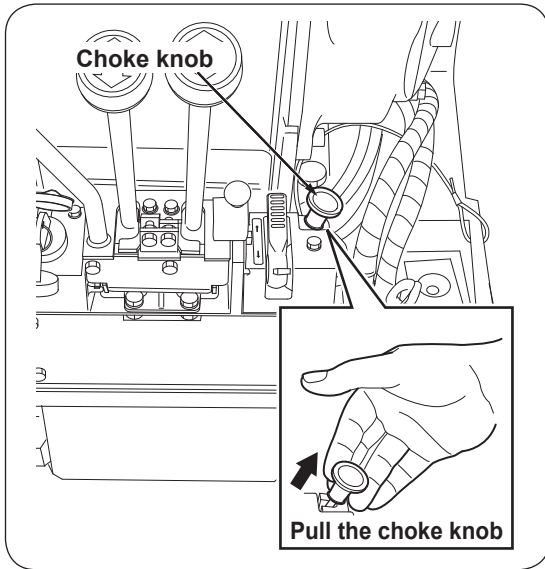

● Starting in a cold weather

When it is hard to start the engine in lower outside air temperature, take steps as follows:

1 Pull the choke knob and pull the accelerator lever a bit to get the engine speed somewhat higher than idling.

2 Turn the switch key to **START** position to start the engine.

3 Release the key immediately after the engine has started running. The key returns to **ON** position by itself.

4 Return the choke knob to its original position after the engine speed has increased.

5 Return the accelerator lever to idling position after the engine makes a steady running.

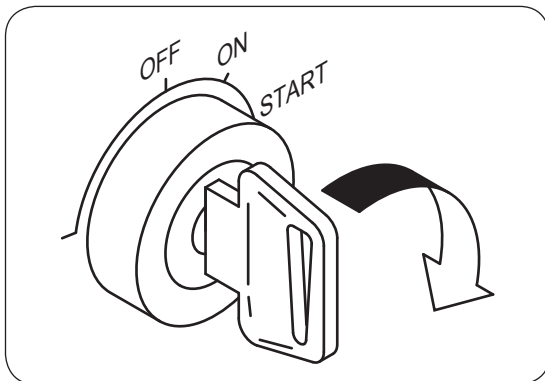

◆2. Steps to be taken after engine has started

 **CAUTION**

★ Do not make the engine to accelerate abruptly before it has been warmed up.

After the engine has started, do not rush into crawling the crane but take the steps as follows:

1 After the engine has started, check for unusual noise, vibration, heat, bad odor, and for fuel leakage. If found anything wrong, stop the engine to find the cause.

2 The warming-up allows not only the lubricant to circulate well enough through each operating section but also allows the engine to be warmed up gradually to raise temperature of oil which in turn creates the better operating conditions.

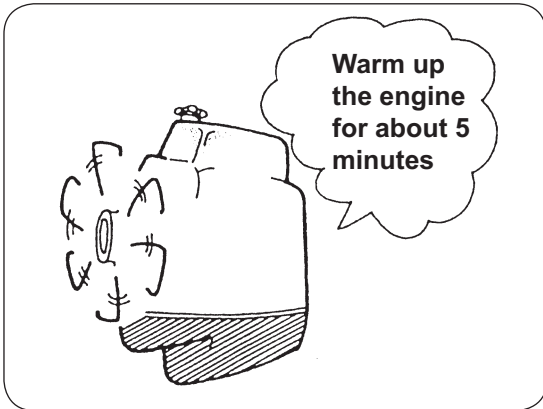

4 How to Crawl

WARNING

- ★ Start the crane crawling after the safety around the crawler has been confirmed and make a sign when starting the crane crawling.
 - ★ Carry out crawling operation by standing in front of the crawling lever.
 - ★ Keep anyone away from the crane.
 - ★ Do not crawl the crane with someone or an object mounted on the crane.
 - ★ Arrange those who guide at a place where it may be unsafe and you have a blind spot.
 - ★ Crawl the crane as slowly as possible while making a turn.
 - ★ If crawling backward, watch where it is to be crawl and restrain crawling speed.
 - ★ Run the crane slowly when making a sharp turn and crawling on a rough road.
 - ★ Before leaving the crane, shift the crawling lever stand to storing position and stop the engine.
 - ★ Avoid running over obstacles.
 - ★ If it is unavoidable, crawl at low speed and keep the crane to lean less than 10° to the side.
 - ★ When parking the crane on the street is unavoidable, set up safety devices such as a sign, a barricade, and a blinking light so that passing of other vehicles and pedestrians may not be disturbed.
 - ★ Put a pallet against the rubber crawler when parking the crane for a long period of time.
 - ★ Do not park the crane over a place where withered grass or straw, which is flammable.
 - ★ This may cause a fire by heat of exhaust pipe or exhaust fume.
 - ★ When crawling the crane on a water filled area, observe to crawl it within allowable depth of water.
 - ★ Allowable depth: Up to the center of crawling motor or of sprocket.
 - ★ In case where the machine is forced to turn on the spot (spin turn), be sure to stop the movement of the machine first, allow the engine to run at a low speed to make it turn slowly and gently.
- An abrupt turning not only damages the rubber crawler badly but also causes the machine to bounce from which may invite a very dangerous situation.

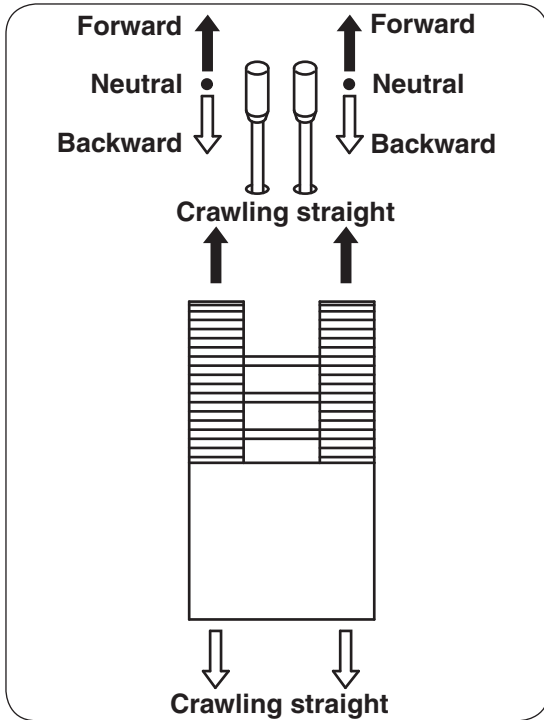

◆1. Starting, crawling, stopping the crane

1 Make sure that the crawling lever stand is shifted to "Crawl" position.

2 Shift the crawling levers (left and right) simultaneously to the other side to make the crane to crawl forward and shift the levers to this side makes it to move backward..

Shifting the levers to neutral together allows the brake to be applied automatically.

! WARNING

★ When riding over an obstacle or going up and down a hill, do so straight-on. If you operate the crane at an angle, it may become unbalanced and tip over.

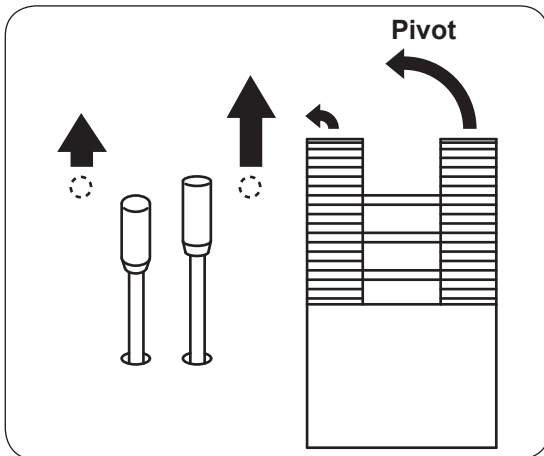

◆2. Making a turn

● Making a turn while moving

When traveling forward: It turns to the left (right) by shifting the right (left) traveling lever much further than the left (right) traveling lever.

When traveling backward: It turns to the left (right) by shifting the right (left) traveling lever much further than the left (right) traveling lever.

! WARNING

Do not operate the right (left) traveling lever with the left (right) traveling lever put at its neutral position. Otherwise, the rubber crawler damages and the machine bounces from which may invite a very dangerous situation. In case where the machine is forced to operate this way, be sure to stop the movement of the machine first, allow the engine to run at a low speed to operate it slowly and gently.

HOW TO OPERATE CARRIER

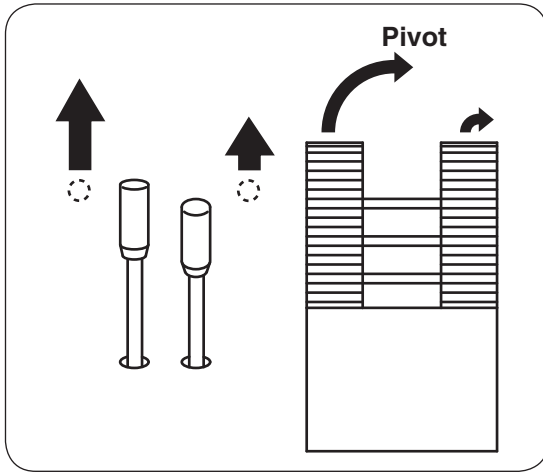

● Making a turn when the machine is at a standstill

Shifting the traveling levers both to the right and to the left forward at the same time allows the machine to turn to the right (left) if the left (right) traveling lever is moved much further than the right (left) traveling lever. Shifting the traveling levers both to the right and to the left backward at the same time allows the machine to turn to the right (left) if the left (right) traveling lever is moved much further than the right (left) traveling lever.

! WARNING

Do not operate the right (left) traveling lever with the left (right) traveling lever put at its neutral position.

Otherwise, the rubber crawler damages and the machine bounces from which may invite a very dangerous situation.

In case where the machine is forced to operate this way, be sure to stop the movement of the machine first, allow the engine to run at a low speed to operate it slowly and gently.

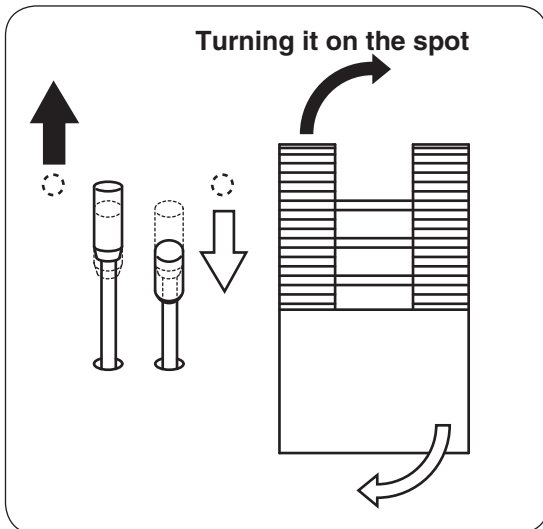

● Making a turn on the spot (spin turn)

As a rule, do not make the machine to turn on the spot.

In case where the machine is forced to turn on the spot, be sure to stop the movement of the machine first and allow the engine to run at a low speed.

Shifting the left (right) traveling lever forward and the right (left) traveling lever backward slowly allows the machine to turn to the right (left) on the spot.

! WARNING

An abrupt turning not only damages the rubber crawler badly but also causes the machine to bounce from which may invite a very dangerous situation.

11. HOW TO OPERATE CRANE

1 Designation of each control lever and location

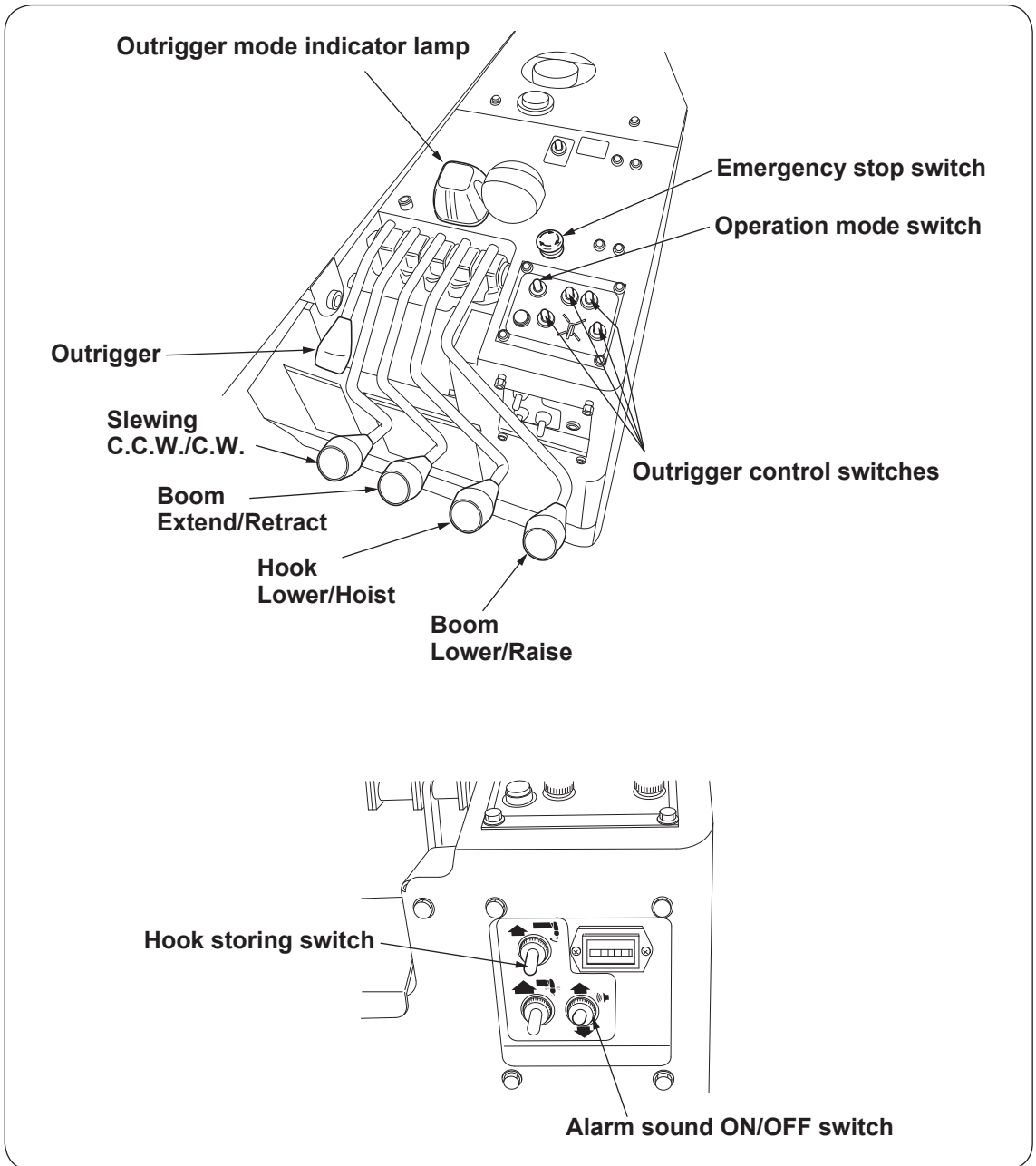

2 Preparation before operation

WARNING

★ Do not let anyone stand under or in front of the hook as it swings when it is released from the hook holder. Failure to do this may invite an accident.

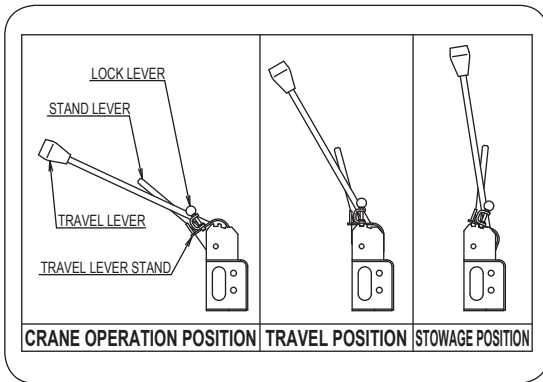

1 Set the crawling lever stand to "Crane" position.

2 Make sure that each lever for controlling crane and outriggers is at its neutral position.

3 Start the engine. Set the engine speed at somewhat higher than idling. (Running the engine idle may result in engine stop when operating crane functions).

4 Turn the operation mode switch to "Outrigger". (Outrigger mode indicator lamp lights.)

5 If the turnover prevention device is equipped, turn ON the alarm switch.

6 Turn ON the alarm sound switch.

CAUTION

★ In winter time, do not rush to operate the crane even after the steps illustrated above, preparation before operation, have been completed. Run the hydraulic pump for a while to warm it up.

★ Since viscosity of hydraulic oil is too high when the oil temperature is low, high-speed running of hydraulic pump fails the oil to be circulated so that the pump may be damaged.

3 Procedures to set up outriggers

WARNING

★ Crane operation without setting up the outriggers is strictly prohibited.

★ Do not operate the crane and extend outrigger cylinders and inner boxes while outriggers have been stored.

★ When setting up the outriggers on a rough ground or on a slope, be sure to place a support (such as plank, steel plate etc.) under the outrigger foot flanges to keep the crane level.

In addition, when the crane is to be operated on a soft ground, take the same measures to prevent the outrigger foot flanges from sinking into the ground when a cargo is lifted up.

Setting up the crane on a ground where it is not solid and firm enough may cause it to be overturned.

★ Do not put your foot under the outrigger foot flange while outriggers are being extended.

It may invite such accident as that the foot may be crushed by the outrigger.

★ Operation with the crane kept leaning makes it unstable when a cargo is lifted up.

Such operation can cause the outriggers to be damaged and the crane to be overturned.

★ The rated load is to be changed according to how far (maximum, half-way, minimum) the outriggers are extended.

Be sure to consult the “sticker concerning PROHIBITED AREA OF CRANE OPERATIONS” for the rated load corresponding to each extension.

★ In normal crane operation, set up the crane level on a solid and firm ground with the outriggers fully extended and lift up the crane body by approx. 2in (50mm) above the ground.

★ When outriggers are extended or being stored, be sure to insert the set pins so that the outriggers may not be rotated unexpectedly.

★ When extending outriggers, extend the inner boxes and allow them to touch the ground by using the outrigger cylinders.

★ Be sure to touch the outriggers to the ground, as the crane may sink into the ground naturally if they are detached away from the ground.

HOW TO OPERATE CRANE

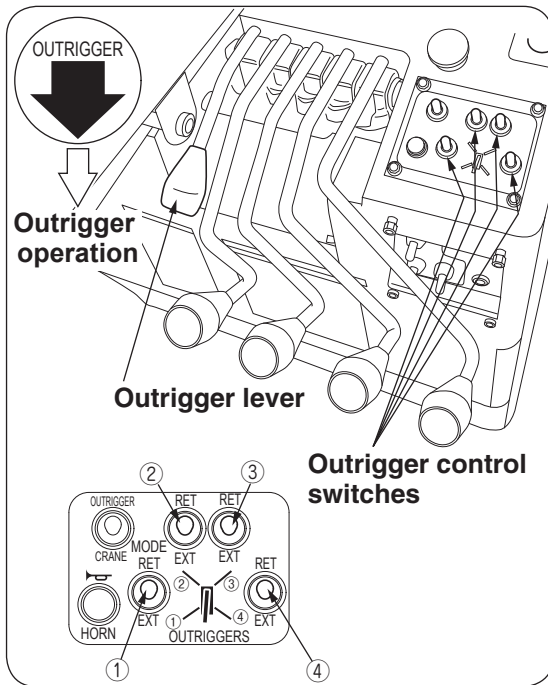

There are four (4) outrigger control switches and each switch is numbered.

Select an outrigger control switch to throw it to desired function and operate the outrigger lever accordingly.

Set up the outriggers as follows:

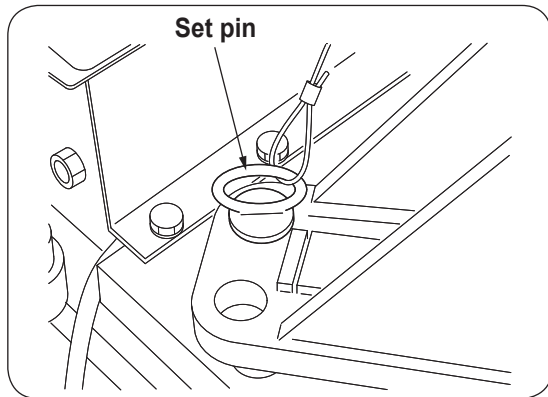

1 Extract the outrigger set pin and insert it in appropriate place while referring to the sticker "PROHIBITED RANGE OF CRANE OPERATION".

2 Remove the lock pin (1) in the arm and hold the knob of outer box firmly to lift it up. Insert the lock pin and retain it with a stopper pin.

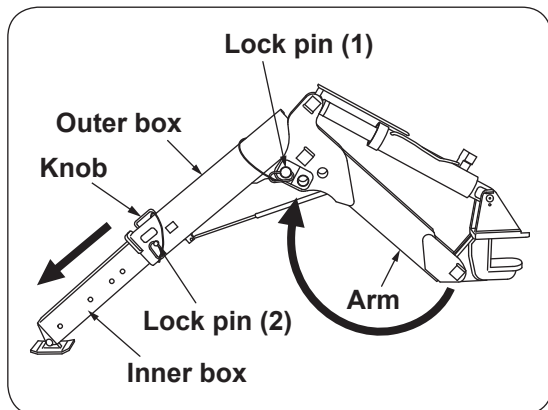

3 Remove the lock pin (2) to pull out the inner box. Insert the lock pin (2) and retain it with a stopper pin.

4 Control each outrigger control lever to adjust that the crane body is raised by approx. 2in.(50mm) above the ground and it keeps level by referring to a level.

! WARNING

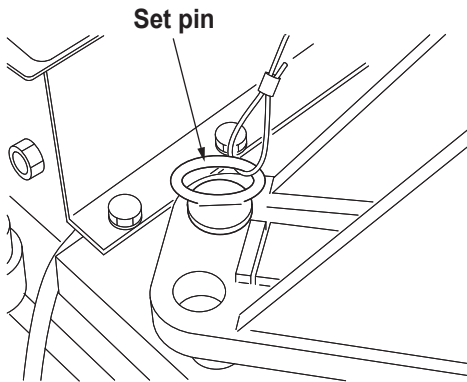

★ Insert each set pin securely when the outriggers are being stored and set up on the ground. Insufficient insertion of the set pins allows them to come off which in turn may make the crawler to lose balance causing the crane to be overturned.

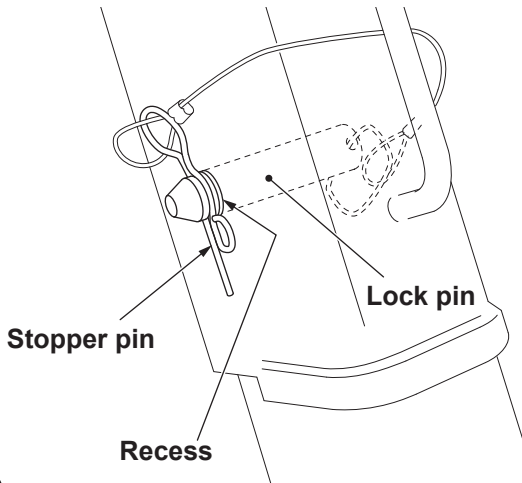

★ After the lock pin has been inserted, be sure to put the stopper pin in the recess to retain it securely. If neglected, the lock pin gradually escapes during crane operation which in turn causes overturn.

! DANGER

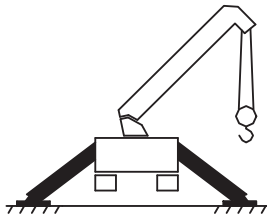

★ Before operating the crane it is mandatory to set up all the outriggers.

HOW TO OPERATE CRANE

◆ Extension of outriggers and rated load

⚠ WARNING

★ Rated load is expressed when the outriggers are extended to maximum and to a distance below maximum with their spread angle set the same.

As a rule, set the outriggers extended to their extremes and with the spread angle of each 55° and 50° .

When any one of 4 outriggers has not been set to the maximum extension, “not max ext. outriggers” in “rated loads” is to be applied which must be observed.

★ Since prohibited range of crane operation is specified according to spread angle of outriggers, confirm it on the sticker.

If it is failed to observe, the crane may be overturned.

Outriggers extended to maximum

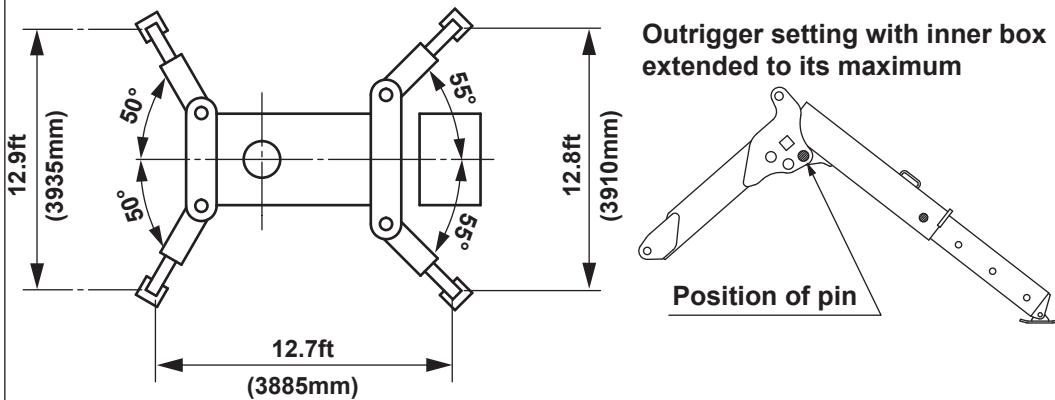

Example: Outrigger setting to a distance below maximum (Figure shows they are set to minimum extension).

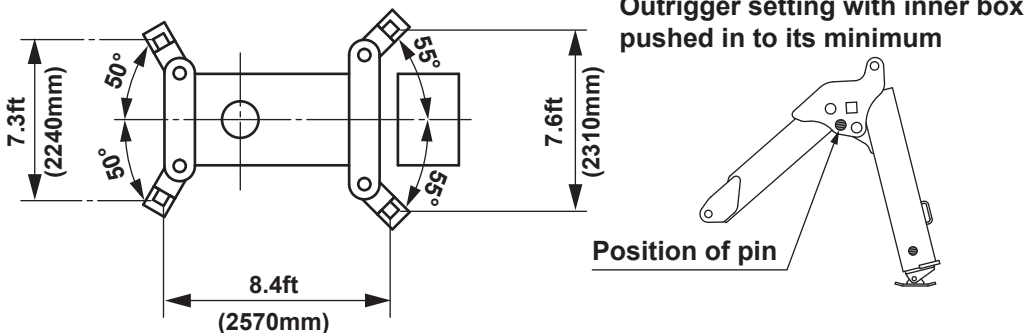

4 How to operate boom for "derricking" (raising and lowering)

WARNING

★ An abrupt crane operation while a cargo is being lifted up gives an excessive shock to the crane which may cause the crane to be damaged or the crawler to be overturned.
Be sure to control levers slowly.

★ The longer the boom is extended, the faster a cargo is lifted up and down by boom derricking operation.
Operate the boom so that a cargo can be lifted up slowly.

★ When lowering boom with a cargo hoisted, the working radius increases which in turn decreases the capacity specified in the rated load chart.

Check the readings of boom angle chart to confirm the safety before the boom is lowered.

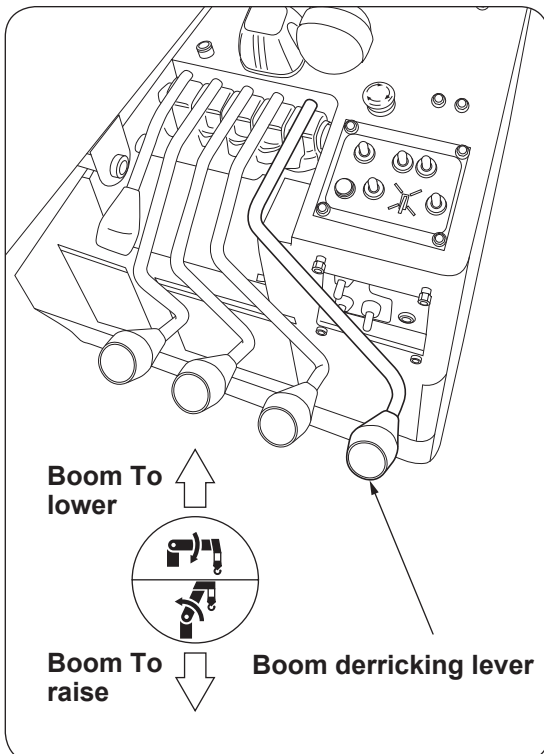

To raise

Shift the lever to "RAISE" to raise the boom.

To lower

Shift the lever to "LOWER" to lower the boom.

To stop

Return the lever to neutral position to stop the boom derricking.

◆ Power automatic accelerator

When the control lever is shifted further to "RAISE" or "LOWER", the engine speed increases according to the movement of the lever which in turn increases derricking speed of the boom as the lever is interlocked with the accelerator.

5 How to hoist and lower the hook

WARNING

★ Pay attention that the hook will not be over-wound.
Be sure to turn ON the “alarm sound ON/OFF switch”.

★ If the hook hits against the boom top due to being over-wound of the hook, it may cause damage to the wire rope and the sheaves at the boom top and may cause the lifted cargo to fall.

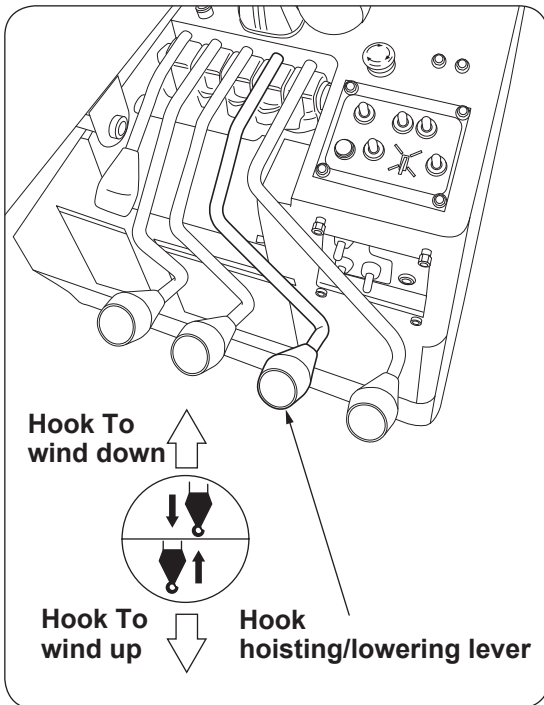

To wind up(raise)

Shift the lever to "UP" to raise the hook.

To wind down(lower)

Shift the lever to "DOWN" to lower the hook..

To stop

Return the lever to neutral position to stop the hook being wound up/down.

◆ Power automatic accelerator

When the control lever is shifted further to "WIND UP" or to "WIND DOWN", the engine speed increases according to the movement of the lever which in turn increases hoisting speed of the hook as the lever is interlocked with the accelerator.

 **CAUTION**

★ Further paying out of the wire rope after the hook has reached the ground causes the rope to be irregularly wound around the drum. Lifting up a cargo with the rope irregularly wound on the drum damages the rope which results in remarkable shortening of its service life.

★ When paying out wire rope longer such as down to underground work site, make sure that more than 3 turns of wire rope shall always be left on the drum.

★ When the first layer of wire rope fails to be wound around the drum firmly and regularly, ropes wound over the first layer may dig into the inner layers to cause an irregular winding, When the wire rope is unwound to or wound up from the first layer of rope, wind it up/down slowly so that the first layer of rope can be wound around the drum firmly and regularly.

★ Stop the crane operation when hydraulic oil temperature exceeds 176°F (80°C).

Oil temperature is apt to rise easily if repeated operation of winding up/down of the hook, especially in a high lift, is carried out.

■ To know approximate oil temperature by sense of touch:

158°F (70°C)	You can touch the oil tank (Lower part) with the palm of your hand for 3~4 seconds.
176°F (80°C)	You can touch the oil tank (Lower part) with your finger tip for 1~2 seconds.
194°F (90°C)	The moment you touch the oil tank (Lower part), you will let the hand off by reflex action.

6 How to telescope boom

WARNING

★ If the boom is extended further with the hook come close to the boom top, the hook may hit against the boom top causing the wire rope and the sheaves at the boom top to be damaged, and the fall of lifted cargo may result.

★ Be sure to turn ON the “alarm sound ON/OFF switch”.

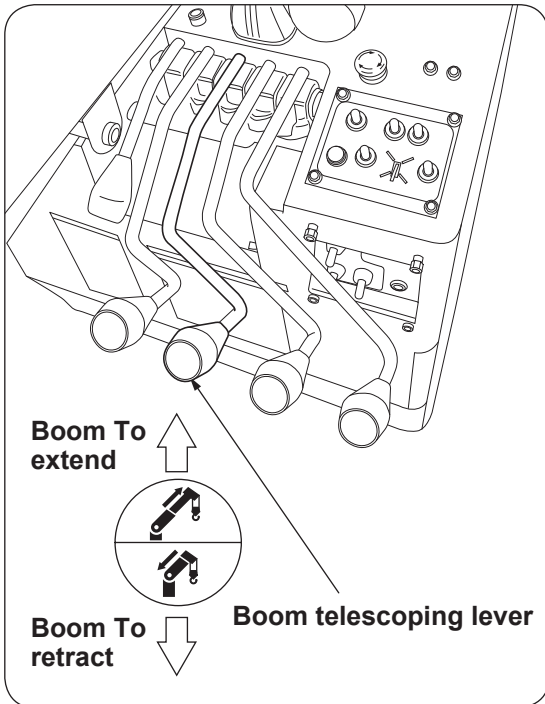

To extend

Shift the lever to "EXTend" to extend the boom.

To retract

Shift the lever to "RETract" to retract the boom.

To stop

Return the lever to neutral position to stop the boom telescoping.

◆ **Power automatic accelerator**

When the control lever is shifted further to "EXT" or "RET", the engine speed increases according to the movement of the lever which in turn increases telescoping speed of the boom as the lever is interlocked with the accelerator.

CAUTION

★ The hook is lifted up as the boom extends and is lowered as it retracts.

When telescoping the boom, pay attention to where the hook is.

7 How to slew boom

WARNING

- ★ Carry out slewing operation slowly without raising the engine speed.
 - ★ Slewing without outriggers set up is strictly prohibited.
 - ★ Control levers slowly to allow the boom to make a smooth start and stop slewing.
- An abrupt lever control with a cargo hoisted allow it to swing which may cause hitting against the other objects and overturn of the crane.
- ★ The longer the boom is extended and the smaller the derricking angle becomes, the lifted cargo moves faster.
- Perform slewing operation slowly with the above in mind.

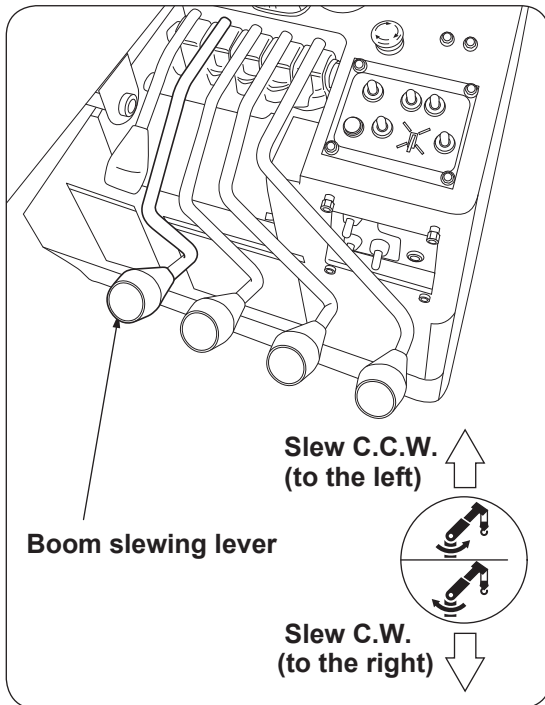

To slew to the right(C.W.)

Shift the lever to "↻" to slew it C.W..

To slew to the left(C.C.W.)

Shift the lever to "↺" to slew it C.C.W..

To stop

Return the lever to neutral position to stop the boom slewing.

◆ Power automatic accelerator

When the control lever is shifted further to "↻" or "↺" direction, the engine speed increases according to the movement of the lever which in turn increases slewing speed of the boom as the lever is interlocked with the accelerator.

HOW TO OPERATE CRANE

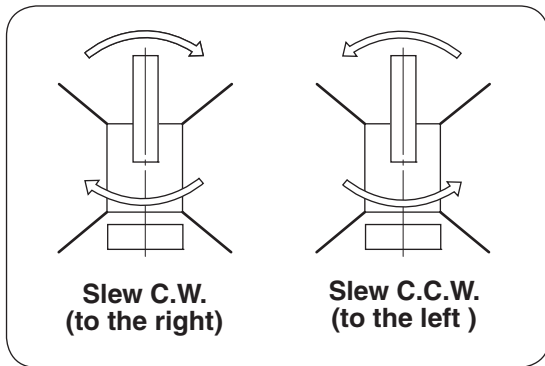





For slewing direction of boom, "slew to the right" means slewing in the direction as the hands of a clock rotate (C.W.) and "slew to the left" means slewing in the opposite direction of clock hands rotate (C.C.W.) when viewed over the crane.

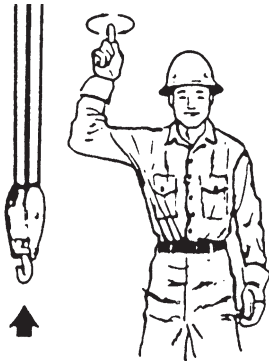
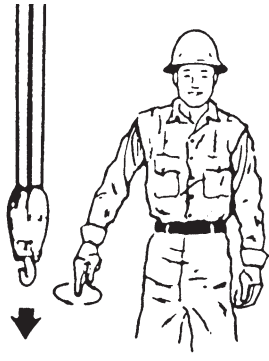
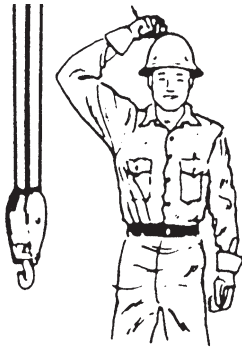
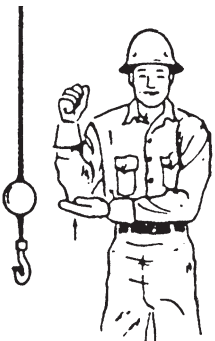
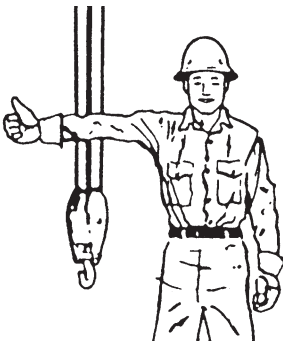
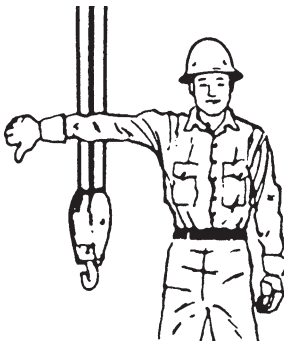
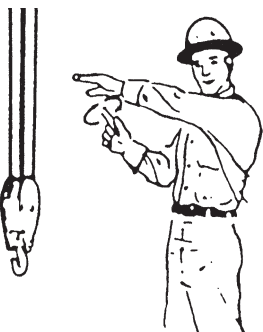
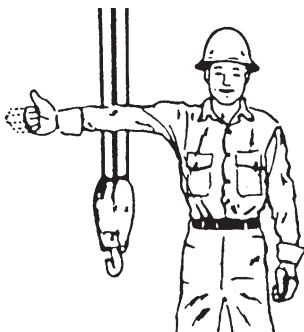
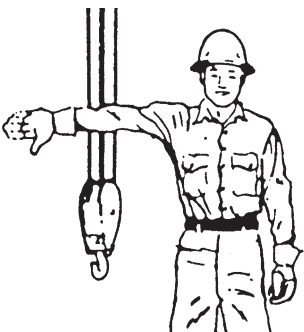

CAUTION

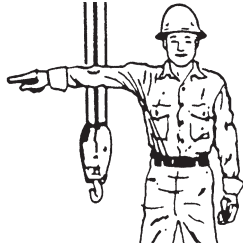
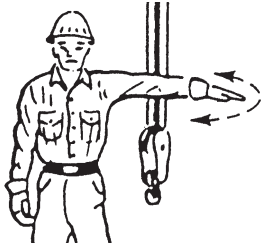
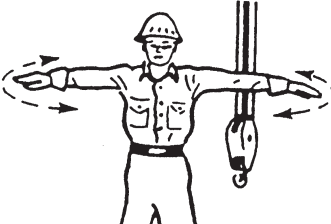
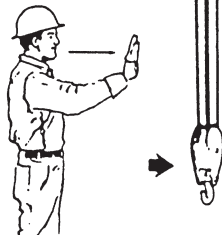
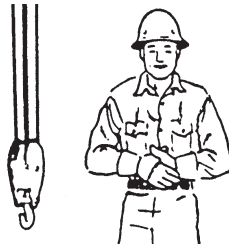
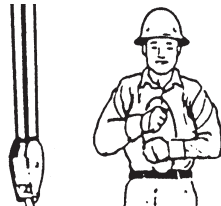
★ Before starting the boom to slew, sound the warning horn to those who are attending or in the working site.

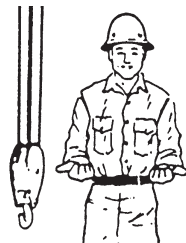
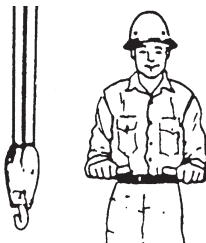
 <p>HOIST. With forearm vertical, forefinger pointing up, move hand in small horizontal circle.</p>	 <p>LOWER. With arm extended downward, forefinger pointing down, move hand in small horizontal circle.</p>	 <p>USE MAIN HOIST. Tap fist on head; then use regular signals.</p>
 <p>USE WHIPLINE (Auxiliary Hoist). Tap elbow with one hand; then use regular signals.</p>	 <p>RAISE BOOM. Arm extended, fingers closed, thumb pointing upward.</p>	 <p>LOWER BOOM. Arm extended, fingers closed, thumb pointing downward.</p>
 <p>MOVE SLOWLY. Use one hand to give any motion signal and place other hand motionless in front of hand giving the motion signal. (Hoist slowly shown as example.)</p>	 <p>RAISE THE BOOM AND LOWER THE LOAD. With arm extended, thumb pointing up, flex fingers in and out as long as load movement is desired.</p>	 <p>LOWER THE BOOM AND RAISE THE LOAD. With arm extended, thumb pointing down, flex fingers in and out as long as load movement is desired.</p>

 <p>SWING. Arm extended, point with finger in direction of swing of boom.</p>	 <p>STOP. Arm extended, palm down, move arm back and forth horizontally.</p>	 <p>EMERGENCY STOP. Both arms extended, palms down, move arms back and forth horizontally.</p>
 <p>TRAVEL. Arm extended forward, hand open and slightly raised, make pushing motion in direction of travel.</p>	 <p>DOG EVERYTHING. Clasp hands in front of body.</p>	 <p>TRAVEL(Both Tracks). Use both fists in front of body, making a circular motion about each other, indicating direction of travel, forward or backward. (For land cranes only.)</p>
 <p>TRAVEL.(One Track) Lock the track on side indicated by raised fist. Travel opposite track in direction indicated by circular motion of other fist, rotated vertically in front of body. (For land cranes only.)</p>	 <p>EXTEND BOOM (Telescoping Booms). Both fists in front of body with thumbs pointing outward.</p>	 <p>RETRACT BOOM (Telescoping Booms). Both fists in front of body with thumbs pointing toward each other.</p>
 <p>EXTEND BOOM (Telescoping Boom). One Hand Signal. One fist in front of chest with thumb tapping chest.</p>	 <p>RETRACT BOOM (Telescoping Boom). One Hand Signal. One fist in front of chest, thumb pointing outward and heel of fist tapping chest.</p>	

8 How to handle extension jib (URW295CP1UR only)

Remove the extension jib attached to upper part of the boom with the pin (1) and attach it to the bracket (1) on the boom top by using the same pin (1).

Work it with the outriggers extended.

When the extension jib will not be used, fasten it to upper part of the boom or remove it to store at some other place.

◆1. Stored position

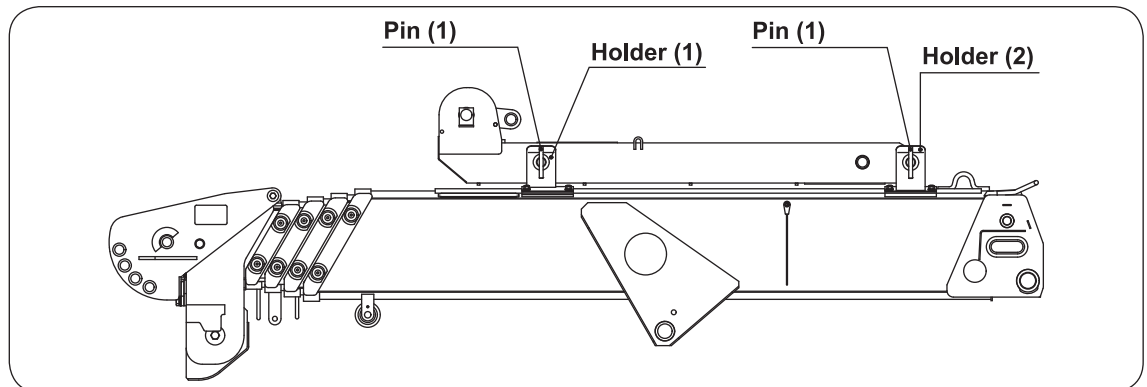

When storing the extension jib, fasten it to both holders (1) and (2) at the upper part of the boom (1) by using 2 pieces of pin (1).

◆2. Operating position

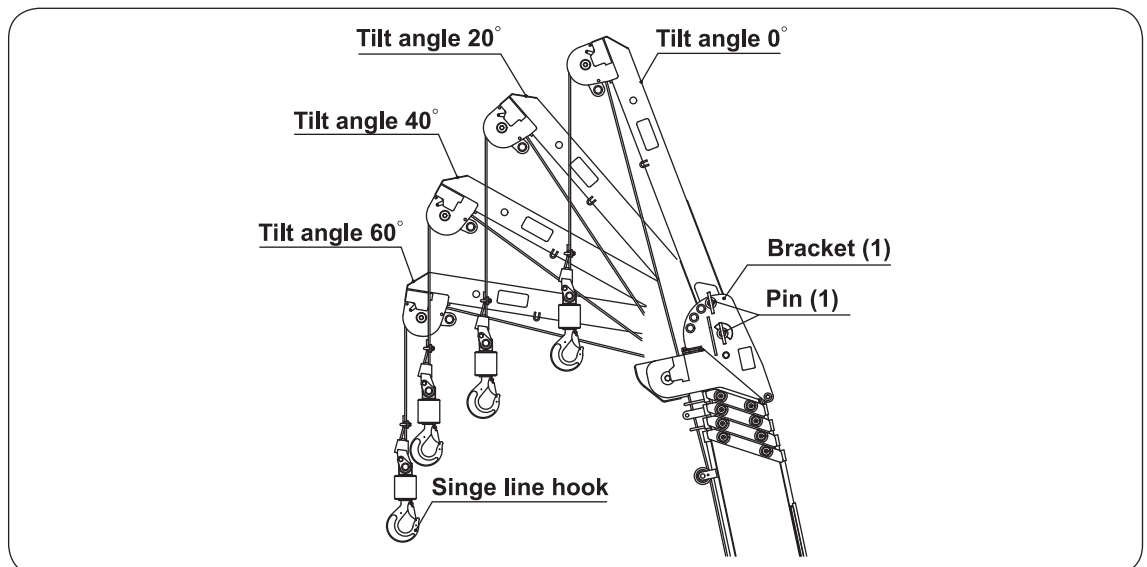

When operating the crane with the extension jib, fasten the extension jib to the bracket (1) at the boom top with pin (1) (2places) to use it by fitting the single line hook.

The tilt angle can be altered by selection of fitting holes into which the extension jib is to be fixed.

◆3. Procedures for changing stored position to operating position

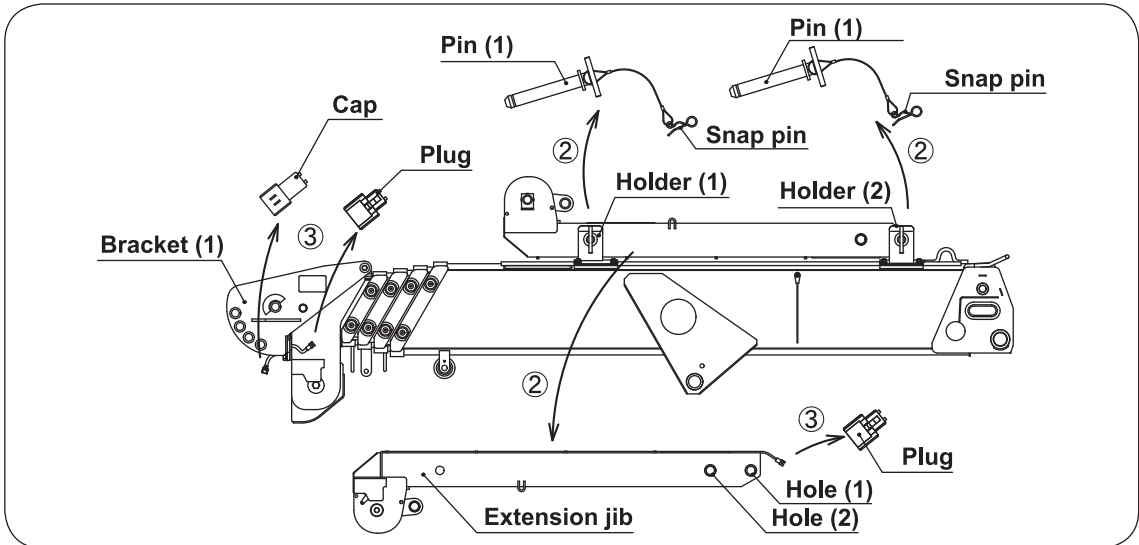

- ① Extend outriggers to maximum position.
- ② Remove the snap pin of the pin (1) to extract each pin (1) out of the holders (1) and (2) and remove the extension jib.
- ③ Remove the caps and the plugs used for waterproof out of wiring connector at the rear end part of extension jib and out of wiring to the bracket (1) of boom top.
(Store the removed caps and plugs carefully.)

CAUTION

★ When operating the crane with the extension jib, outriggers extend to always maximum position.
There is a risk of turn over if outriggers extend to halfway or to minimum position.

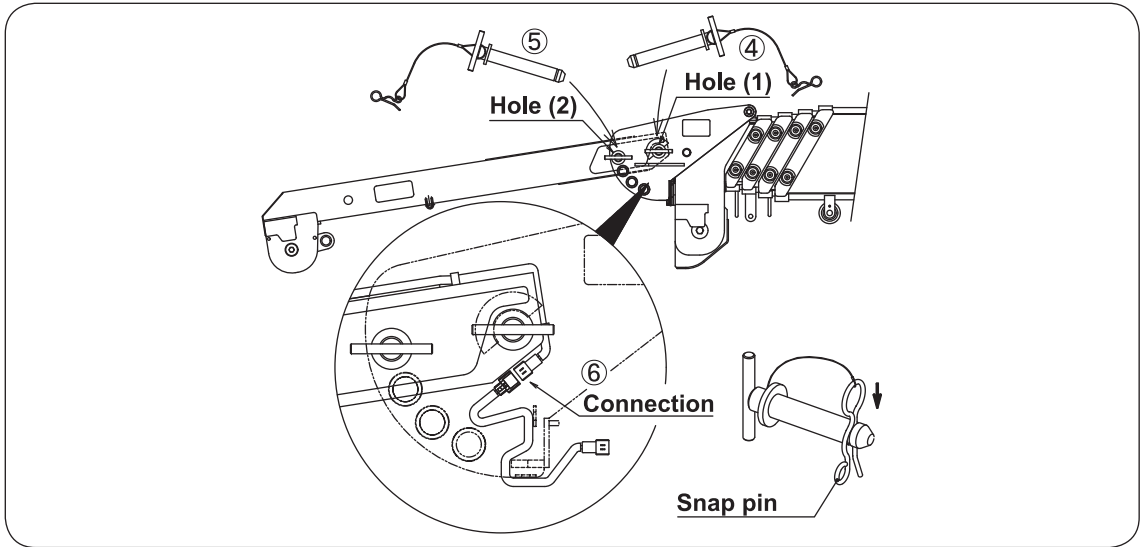

- ④ Align the hole (1) at the end of extension jib with the hole (1) in the bracket (1) at the boom top to insert the pin (1) into the aligned holes (it can be inserted in either direction). After the pin (1) has been inserted, be sure to insert the snap pin into the pin (1).
- ⑤ Match the hole (2) at the end of extension jib with the tilt angle of 0 to insert the pin (1).
- ⑥ Connect the connector at the boom top to the connector at the rear end of extension jib.

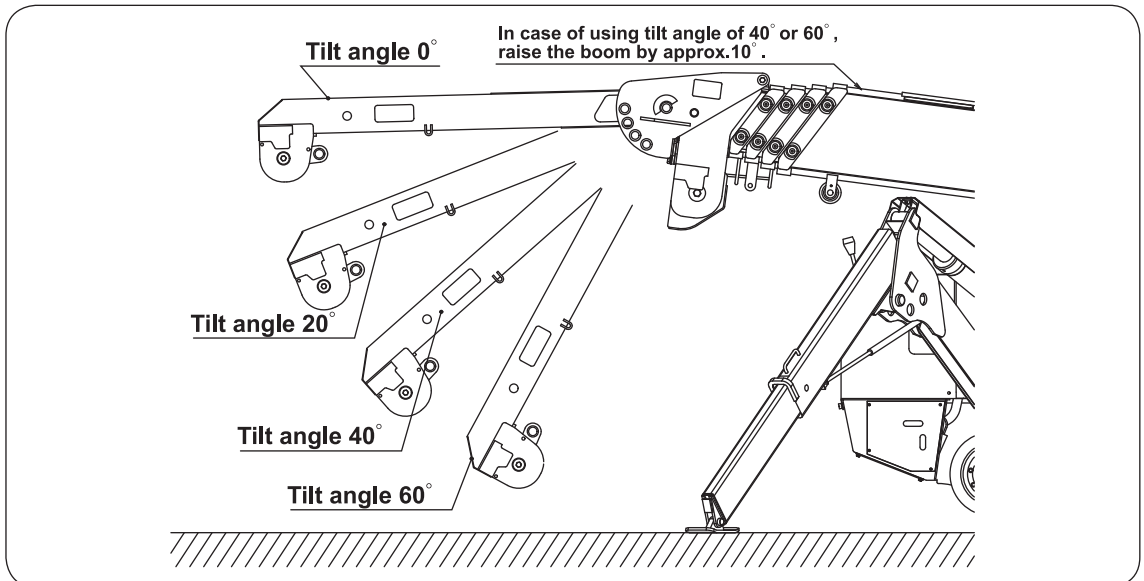

- ⑦ Change the position of holes (2) into which the pin is to be inserted in accordance with desired tilt angle. After the pin (1) has been inserted, be sure to insert the snap pin into the pin (1).
- ※ In case of using tilt angle of 40 or 60 raise the boom by approx.10 in advance as the extension jib touches the ground surface.

HOW TO OPERATE CRANE

◆4. How to pass wire rope

- When operating with extension jib, use the exclusive single rope hook.
- When changing from stored position to operating position, set it by following procedures illustrated above.
- After the extension jib has been set, change passing of the wire rope so that it passes through the extension jib by following steps illustrated below.

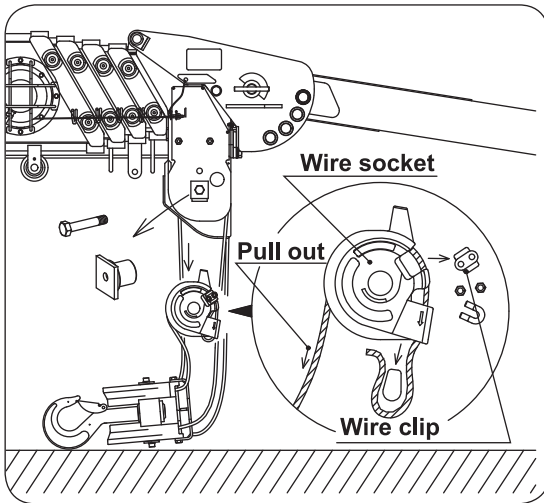

1. Lower the hook for 4-part line hooking onto the ground to remove the wire clip out of the wire socket. Then, detach the wire rope end from the wire socket.

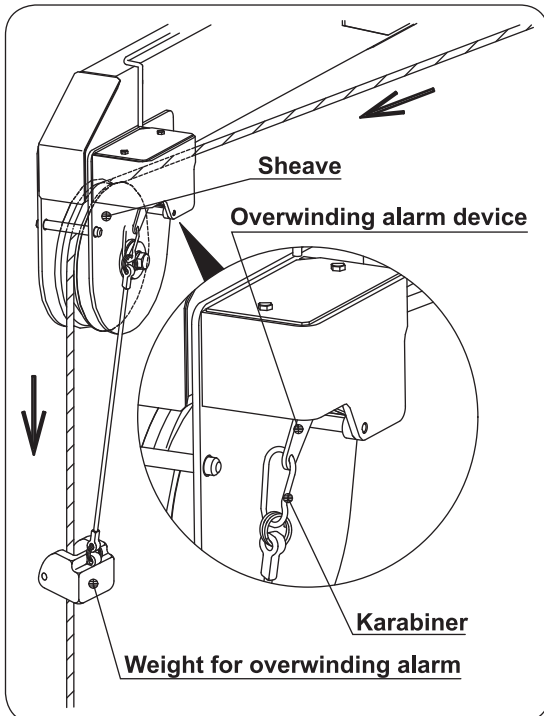

2. Attach the karabiner for the "weight for overwinding alarm" to the "overwinding alarm device" at the top of extension jib to pass the wire rope as illustrated in the figure.

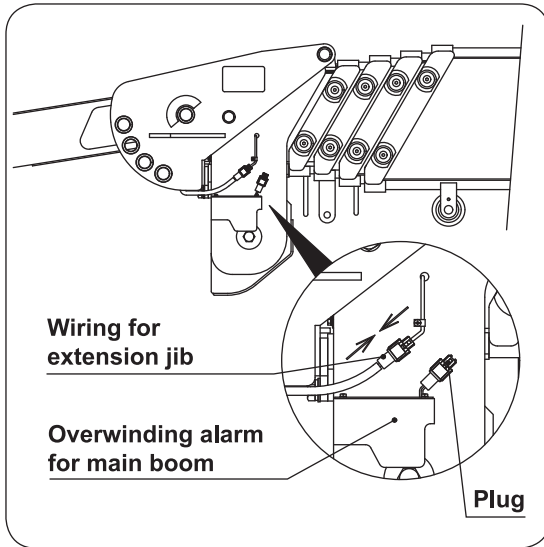

3. Connect the wiring of "overwinding alarm device" with the wiring for extension jib. Attach the plug for waterproof to the "overwinding alarm" for main boom.

⚠ CAUTION

- ★ The overwinding alarm will not sound even if the hook is under overwound condition with the voice switch turned OFF. Be sure to turn the switch ON before starting crane operation and check that the alarm sounds when the weight for overwinding alarm is put up.
- ★ Since the length of wire rope hanging the weight is specified by laws and regulations concerned, do not make it short without any reason.
- ★ The alarm also sounds if the wiring (cords) connected to the overwinding detector at the boom top is broken. In this case, ask a UNIC authorized service shop for repair.

HOW TO OPERATE CRANE

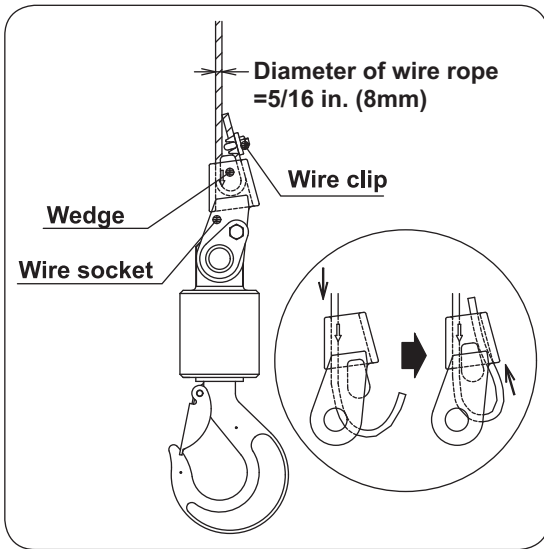

4. Let the wire rope pass through the wire socket for single line hook and be sure to fasten the rope end securely by using the wire clip as illustrated in the figure. Pass the wire rope along the arrow mark indicated on the wire socket. If the wire rope is passed from the opposite direction service life of the wire rope shrinks as it is kept bent all the time.

- This completes change of passing the wire rope from the main boom to the extension jib.
- For change of passing the wire rope from the extension jib to the main boom, take steps in the reverse order illustrated above. For fastening the rope end to the wire socket, refer to the section , "MAINTENANCE AND INSPECTION OF CRANE" , illustrated in the separate OPERATOR'S MANUAL for mini-crawler crane.

CAUTION

- ★ When working the wire rope, be sure to wear leather gloves for crane operation.
- ★ Be sure to operate the crane with outriggers maximum extended.
- ★ Since lateral deflection and/or bend of the boom will become larger when the extension jib has been attached, slow down the speed of crane operation of slewing and raising/lowering of the boom to prevent the overturn of the crane.
- ★ When making a cargo touch the ground, pay special attention to slinging work as the hook may make an abrupt turning.
- ★ When you use the extension jib or the searcher hook ,do not use 4-part line hooking.
- ★ When you use 4-part line hooking, you must always store correctly both the extension jib and the searcher hook.
- ★ The rated loads are performance when outriggers extended to maximum.

◆5. Procedures for changing operating position to stored position

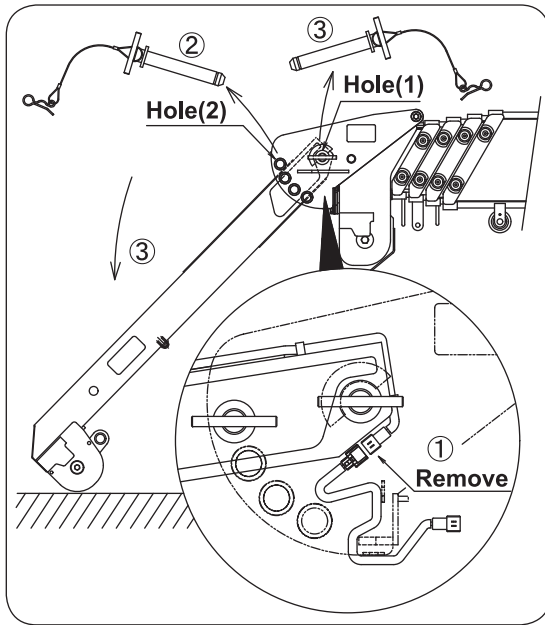

1. Disconnect both the connector at the rear end of extension jib and the connector for wiring to bracket (1) on the boom top.
2. Extract the pin (1) out of the hole (2) in the bracket (1) on the boom top.
3. Lower the extension jib onto the ground by using the pin (1) in the hole (1) as a point of support to extract the pin (1).
4. Fit the plugs and the caps for waterproof on the connector at the rear end part of extension jib and on the wiring to the bracket (1) on the boom top.
5. Attach the extension jib to the holders (1) and (2) at upper part of boom (1) to fix it with pin (1) (2places) or to store it at some other place.
6. After each pin has been inserted, be sure to insert the snap pin.

◆6. When in normal crane operation

- ① Change the wire rope to put on the hook for 4-part line hooking.
- ② Change the wiring to the overwinding alarm device from the wiring for extension jib to that for main boom.
- ③ Remove the extension jib to store it in the holder at upper part of the boom (1) or to store it at some other place.
- ④ In case where the storing extension jib may prevent smooth working, remove the bracket (1) to store it at some other place.

9 How to handle searcher hook (URW295CP1UR only)

- The searcher hook is used by fitting it to the bracket (2) on the top of extension jib.
- Follow the procedures previously mentioned when setting the extension jib from stored position to operating position.
- Take off the wire rope end out of the wire socket to fasten it to the column.
- After the extension jib has been set, follow the steps illustrated below to attach the searcher hook.

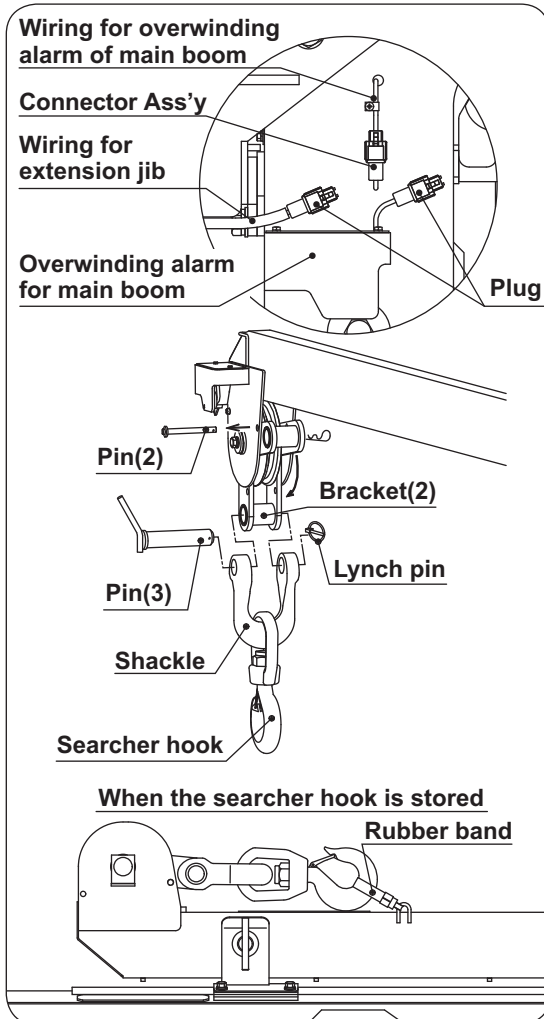

- ① Connect the connector ass'y (type of wiring is looped) in the wiring for overwinding alarm device of main boom.
 - ② Fit the plug used for waterproof on the wiring for extension jib and overwinding alarm for main boom.
 - ③ Remove the pin (2) fastening the bracket (2) on the top of extension jib. (While the searcher hook is being used, remove the pin (2) to store it at some other place.)
 - ④ Pass the shackle through the searcher hook to fasten it to the bracket (2) by using the pin (3). After the pin (3) has been passed through, be sure to fasten it with a lynch pin.
 - ⑤ When the searcher hook will not be used, remove it by following reverse order for storage.
- * When the searcher hook is stored, it can also be fastened by rubber band being attached.

CAUTION

★ In case where a cargo is lifted up by using searcher hook, slow down the speed of crane operation to prevent the crane from being overturned as the center of gravity shifts upward.

★ Be sure to operate the crane with outriggers maximum extended.

10 How to remove and fit bracket

• If the extension jib or the searcher hook will not be used for a long period of time, the bracket (1) on the boom top can be removed. Remove or fit the bracket (1) by following the steps illustrated below.

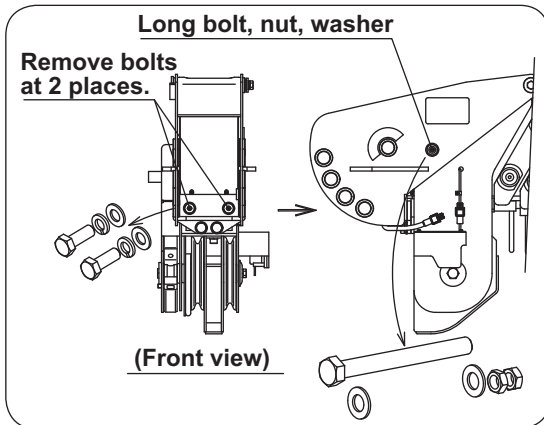

1. Unfasten 2 pieces of bolt at upper side in front of the top of the boom to remove washers and spring washers of 2 pieces each.
2. Remove 2 pieces of nut joining together being fastened to the side of bracket (1) to extract the long bolt out of the bracket.

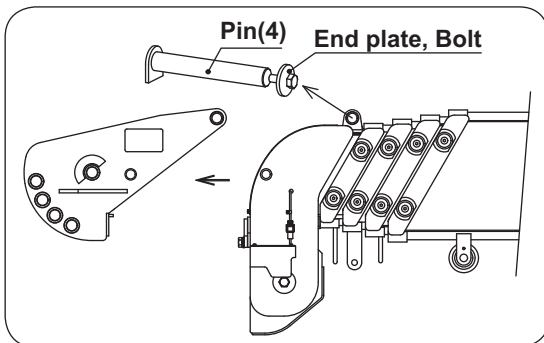

3. Remove the bolt on the end plate at the upper part of the pin (4) in the bracket (1) to remove the bracket while it is being supported after the pin (4) has been extracted.

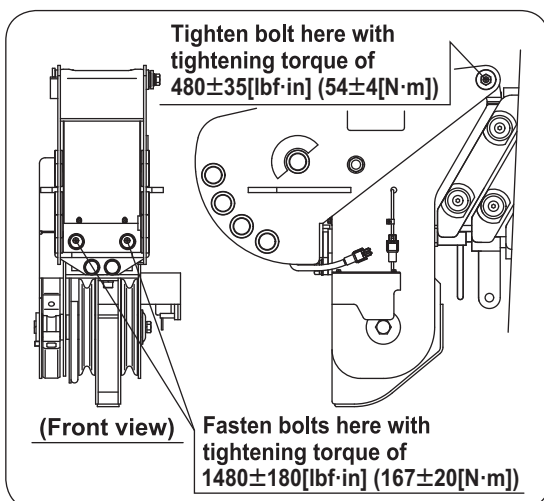

4. When fitting the bracket, take steps in reverse order of removal. Fasten each bolt with the tightening torque of : 480 ± 35 [lbf·in] (54 ± 4 [N·m]) for bolt on the end plate at the upper part of the pin (4) and 1480 ± 180 [lbf·in] (167 ± 20 [N·m]) for bolt at the front bottom.
For the long bolt on the side, fasten the nut lightly to an extent that the bracket will not be deformed, then secure it by fastening two nuts each other.

11 How to store crane

WARNING

★ Be sure to store the boom from the left hand side of the operator's position.

★ Be careful about the storing the crane and slow down operating speed as the distance between the boom and each control lever becomes close.

In addition, be sure to store the crane to observe the procedures as follows.

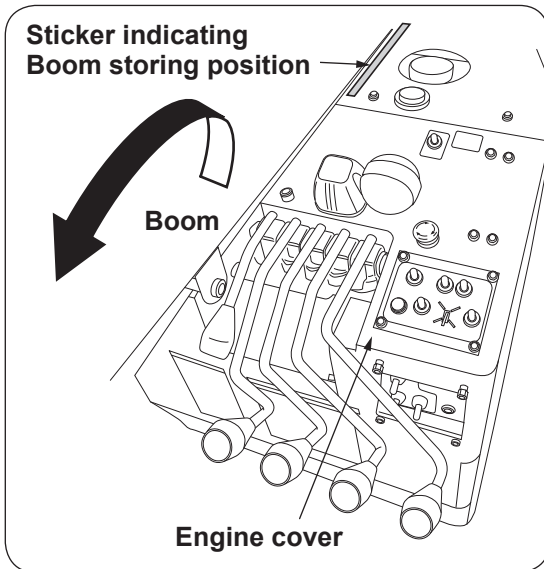

- 1** Retract the boom.
- 2** Slew the boom to a place close to the "sticker for boom storage".
- 3** Lower the boom to its extreme.
- 4** Position so that the side of boom of your side comes right over the sticker indicating storing position stuck on the engine cover.
- 5** Store the hook.

12 Procedures for storing hook

WARNING

- ★ Never try operating the crane by controlling the hook storing control switch as this is dangerous.
- ★ Store the hook after all boom sections have been retracted and lowered fully.
- ★ Do not operate the hook storing control switch and other control lever at the same time which may cause a malfunction and a breakdown.

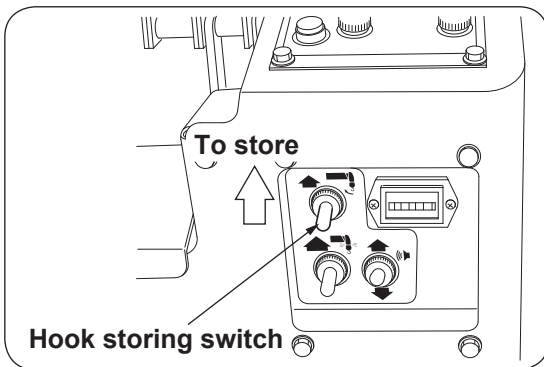

■ URW295CP1UR

1 Hoist up the hook with the "hook storing switch" turned to "Store". The hook stops being wound up when the hook hits against the weight of over-winding alarm.

2 Wind up the hook slowly by controlling the hook storing switch after the hook is at a standstill. Release the switch after the hook has been stored.

CAUTION

- ★ Storing hook while it is swinging may cause the boom, the hook, and the wire rope to be damaged.
- ★ Take care that the manual control lever for hoisting/lowering hook moves toward hoisting side when storing the hook.

■ **URW295SCP1UR**

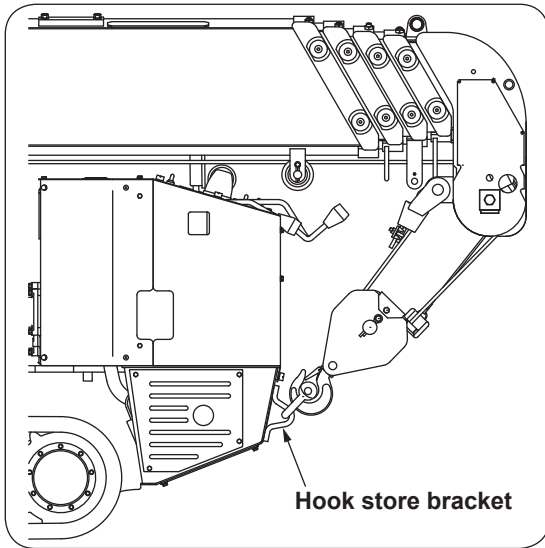

1 Store the crane by following instructions illustrated in the section "**11** How to store crane" (on page 11-25).

2 Put the hook on the storing bracket to wind it up slowly by the hook store switch. Release the switch after the hook has been stored.

13 How to store outriggers

WARNING

- ★ Start storing outriggers after the boom has been stored.
- ★ When storing outriggers, be sure to retract the inner boxes to their extremes after the cylinders have been fully retracted.
(It is very dangerous that inner box may fall by own weight unless the inner boxes are retracted after the cylinders have been fully retracted.)
- ★ When storing the outriggers, be sure to insert the set pins securely so that the outriggers may not be rotated unexpectedly.

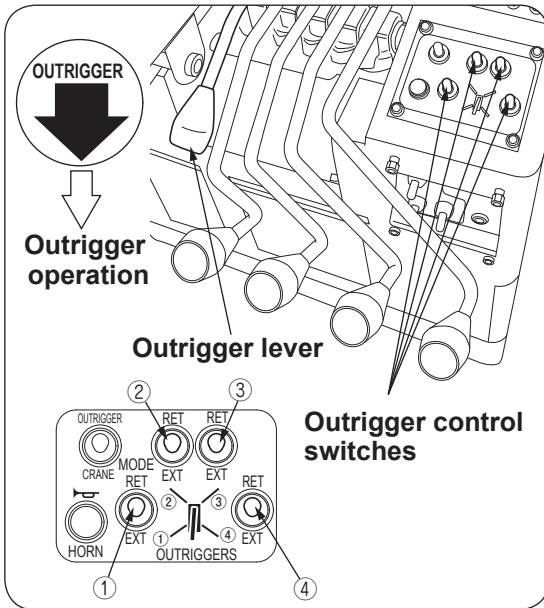

There are four (4) outrigger control switches and each switch is numbered.

Select an outrigger control switch to throw it to desired function and operate the outrigger lever accordingly.

Carry out each operation of the outriggers according to instructions on the sticker.

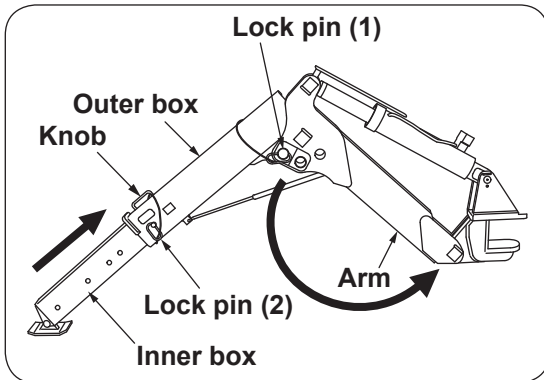

Store the outriggers as follows:

- 1** Retract the cylinders fully first to retract the inner boxes to their extremes.
- 2** Remove the lock pin (2), push in the inner box fully, and insert the lock pin (2) back again. Retain the lock pin with a stopper pin.
- 3** Remove the lock pin (1) in the arm and hold the knob of outer box firmly to push it down strongly. Insert the lock pin (1) and retain it with a stopper pin..
- 4** Remove the outrigger set pin and insert it securely in appropriate place so that the outrigger may not be rotated unexpectedly.

● Remarks

Outriggers may be lowered while crawling for a long time which is not a fault.

14 How to switch manual operation mode to/from radio remote control mode

1 Put the traveling lever stand in the operating position of the crane.

2 Check that each lever for controlling the crane and the outriggers stays at its neutral position.

3 Start the engine.

4 When operated in manual control mode, the outriggers and the crane can only be operated by manual control.

No operation can be carried out through radio remote controller.

The operation mode indicator lamp located on the top of cover will not be lit during manual control mode.

5 Push the mode selector switch to switch it to the radio remote control mode.

6 When it is switched to the radio remote control mode, the outriggers and the crane can only be operated through radio remote controller.

Turn ON the radio remote controller to carry out remote control operation.

The outriggers and the crane cannot be operated by manual control.

7 When switched to radio remote control mode, the operation mode indicator lamp located on the top of cover will be lit. The lamp should always be lit when operated on radio control mode.

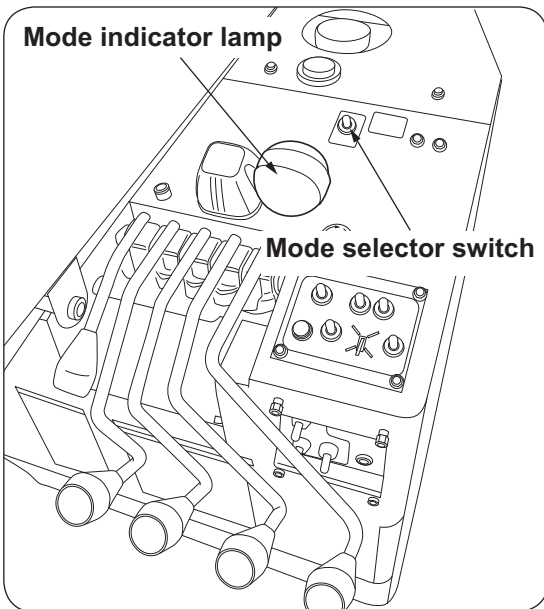



CAUTION

★ The state of each operation mode will be maintained even after the power has once been turned OFF.

Check the operation mode and the operation mode indicator lamp when it has been re-started.

★ The operation mode indicator lamp functions according to each operation mode as follows:

Radio control mode : Operation mode indicator lamp lights.

Manual operation mode : Operation mode indicator lamp goes off.

15 How to operate outriggers when in an emergency

! WARNING

★ Do not touch the engine, muffler and its cover with your bare finger/hand as they are very hot immediately after operation.

★ Be sure to put the cover back again after the outriggers have been stored.

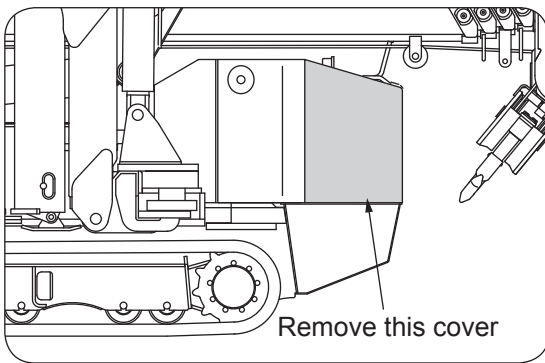

If outriggers fail to make a functioning correctly in normal operation, operate outriggers temporarily according to procedures illustrated below.

1 Remove the cover over the outrigger valves.
Remove the thumb-screws (6 places) to remove the cover.

2 Push the solenoid valve button of outrigger you want to operate with a bar such as screwdriver.

When the outrigger control lever concerned operates, the outrigger functions.

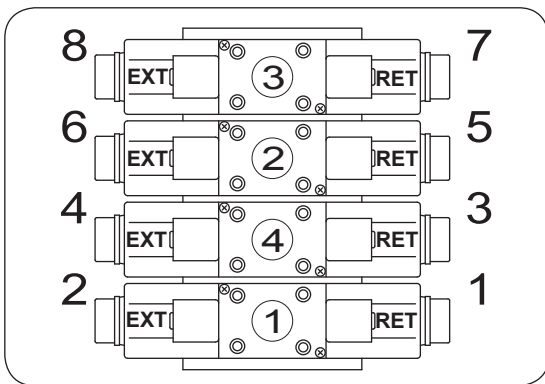

Outrigger to be operated		Operation
Outrigger ①	Retract	Operate lever with button 1 depressed
	Extend	Operate lever with button 2 depressed
Outrigger ②	Retract	Operate lever with button 5 depressed
	Extend	Operate lever with button 6 depressed
Outrigger ③	Retract	Operate lever with button 7 depressed
	Extend	Operate lever with button 8 depressed
Outrigger ④	Retract	Operate lever with button 3 depressed
	Extend	Operate lever with button 4 depressed

! CAUTION

★ While cover is being removed or when depressing a solenoid valve button, work carefully not to damage the electric wiring.

★ After the procedures have been completed, have the crane repaired by the nearest UNIC service shop.

12. U-WAVE, Radio remote control device

1 Request to those who operate the crane

This radio remote control device conforms to regulations for specified small power radio station in the radio wave law.

Use of U-WAVE, "specific low power type" interlocking radio control device, allows the crane operation that will hardly be influenced by radio interference compared with conventional radio remote controllers of weak radio wave type.

In addition, there is no need to get qualification, license, or registration in using the radio remote control device.

Read this manual carefully and understand the contents to use this device.

◆ When making inquiries

When making inquiries, be sure to inform us of model, serial number illustrated on the following label in the remote control transmitter.

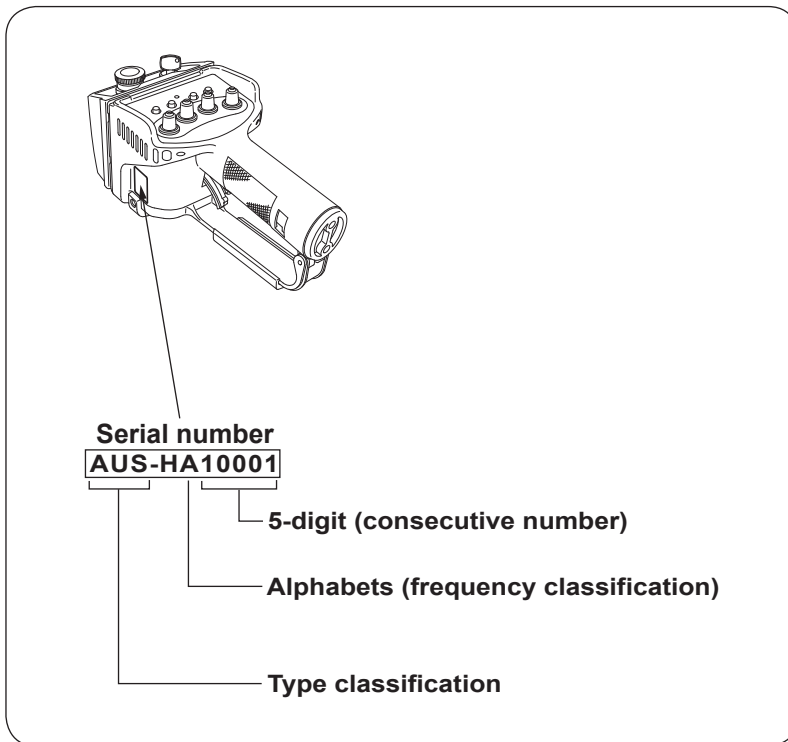

2 Safety precautions

WARNING

★ Observe the cautions for securing safety.
Failure to observe the cautions may invite troubles or serious accidents.

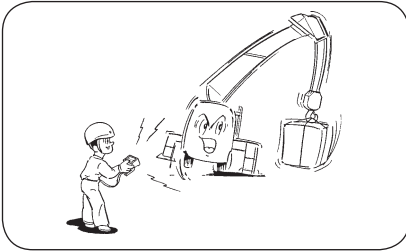

1 In case of crane operation through transmitter, pay attention to circumstances around the crane and to the safety especially for the crane that it will not to be overturned as the operator is to control the crane at a distance.

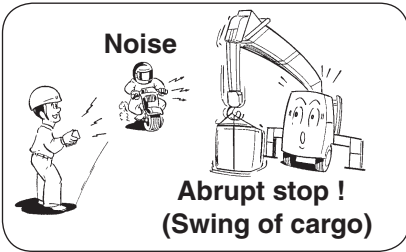

2 Pay attention to the swing of a lifted cargo as the crane may make an abrupt stop when operating it through radio remote control device because it may be affected by radio interference, radio jamming, and noise coming from outside.

In order for the crane system not to be affected easily by noise coming from outside, operate the crane with the following in mind:

- ① Operator must not leave the crane unnecessarily.
Operate the crane within working radius of the crane.
- ② Correct or repair the transmission antenna (located at the stem of transmitter) if it has been distorted or damaged.

● Remarks

Typical source of noise interference:

- Ignition noise emitted from the engines such as of motorcycles or of portable generators.
- Buzzers using contacts such as for alarming when reversing vehicles.
- Electric motors of air-conditioner fan, electric fan, and flashing beacon mounted in cab compartment.

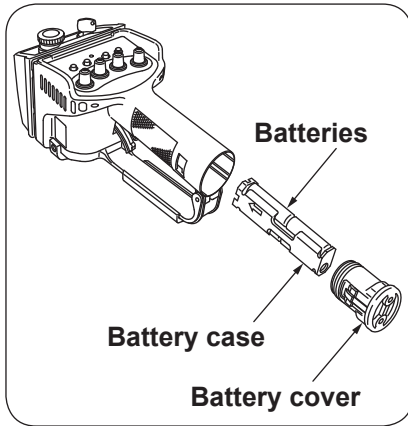

- 3** Remove the batteries when the transmitter will not be used for a long period of time. Otherwise, leakage of battery may result. Be sure to observe the cautions indicated on the batteries as liquid inside will leak due to wrong use of batteries.

- 4** Dispose of used batteries in accordance with local regulations.

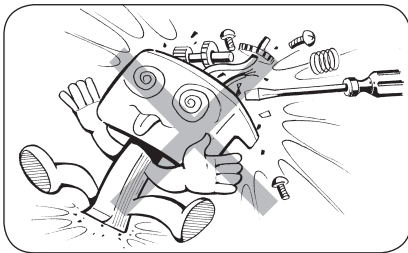

- 5** Never try disassembly or alteration of transmitter, receiver, and control box. Do not remove the stay of transmitter as the transmission antenna is built in it.



- 6** Do not drop or hit the transmitter against something, or give a strong shock, as it may cause damage to the enclosure or breakdown of electronic components.

In addition, dropping or giving a strong shock to the transmitter may damage batteries inside causing generation of heat.

If the transmitter has been given a strong shock, be sure to check batteries and replace them if damaged.

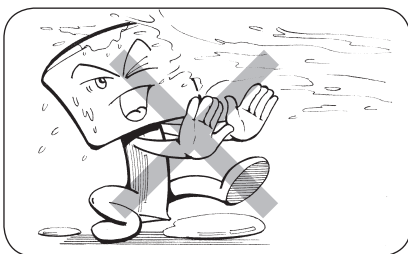

- 7** Do not wash the transmitter with water directly. Wipe dirt off the transmitter with a piece of cloth wet with water or diluted detergent.

Avoid using an alkaline detergent, an alcohol, or a spraying washing detergent for this purpose as they may cause the plastic housing of transmitter to crack.

U-WAVE, Radio remote control device

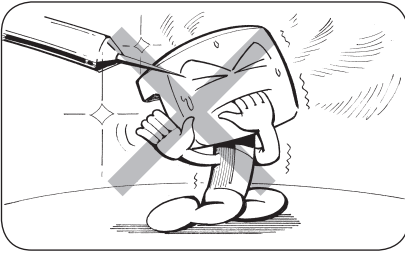

8 Do not thrust the control panel in the transmitter and/or control keys with a sharp article as it may make a hole resulting in entering water inside through it.



9 Do not give the transmitter an abrupt temperature change.

An abrupt temperature change may cause a fault due to building-up condensation inside of the transmitter.

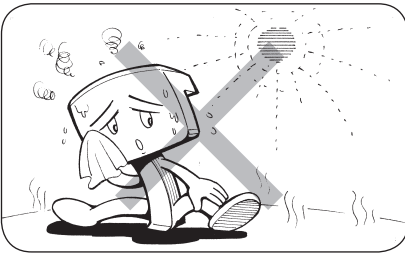

10 Do not put or store the transmitter where:

- It is exposed to direct sunlight.
- It is in front of hot air outlet exhausted out of the vehicle.
- It is close to a heating apparatus or it is too humid.

3 Designation of each equipment

◆1. Construction of radio remote control device (Showing typical mounting example)

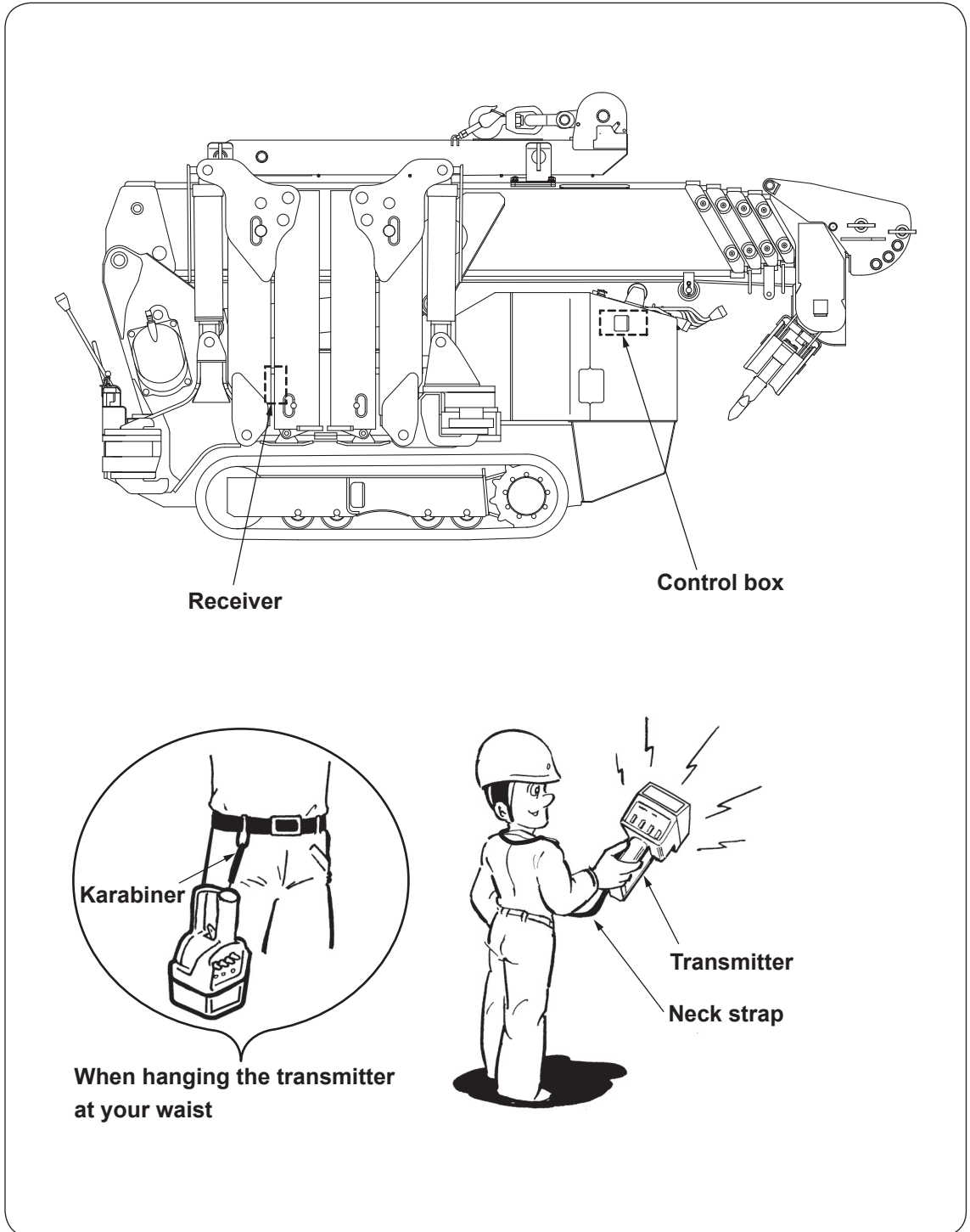

◆2. Designation of each part of transmitter

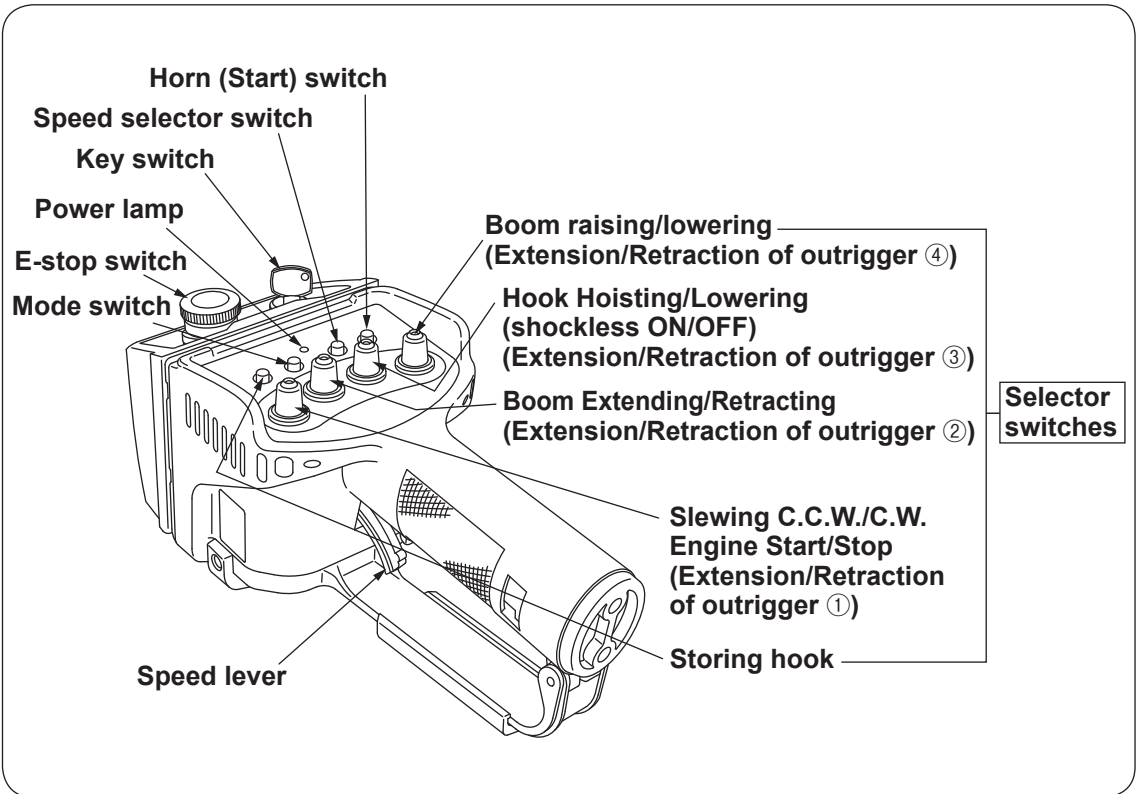

◆3. Designation of each part of receiver

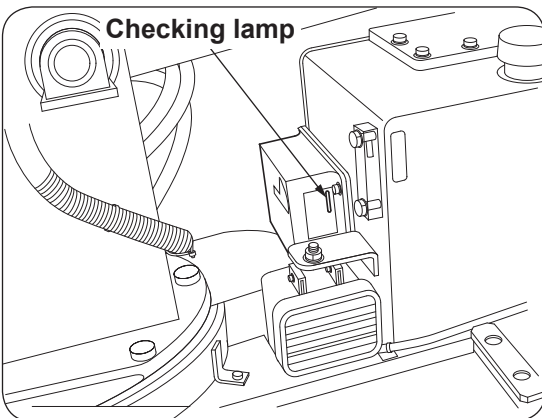

*Receiving antenna is built in the receiver.

◆4. Designation of each part of control box

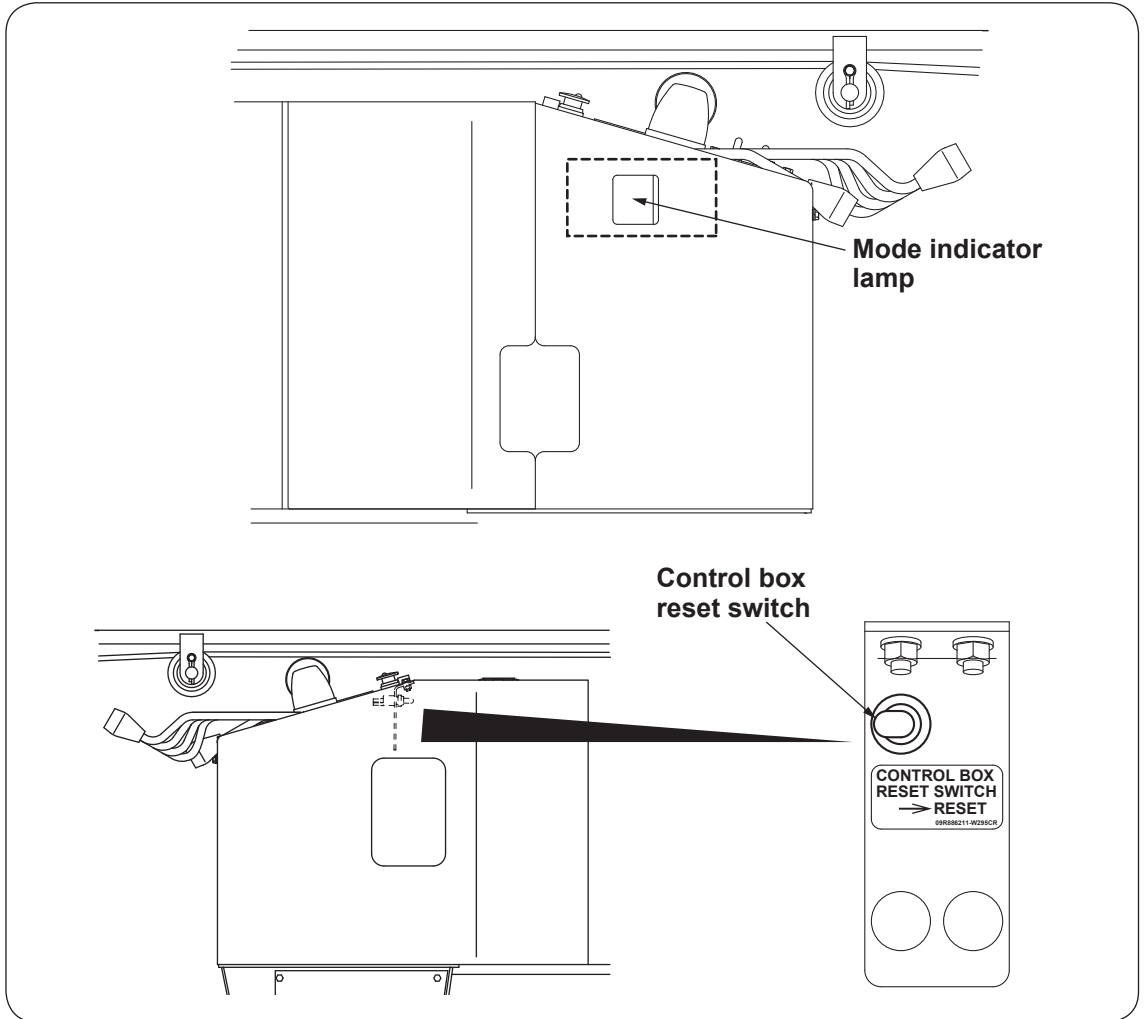

4 Inspection before crane operation

Before starting crane operation, check that the control box functions correctly according to procedures below.

● Remarks

Since power to the "control box" is to be controlled by the engine starter key, it is energized automatically when starting the engine and "mode indicator lamp" in the "control box" lights.

Also, the "power lamp" on the "radio control receiver" blinks in green.

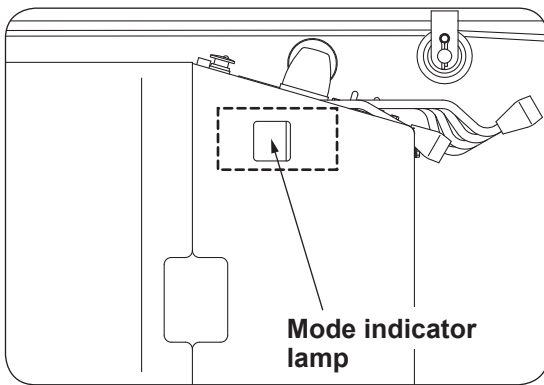

◆ 1. Checking mode indicator lamp

The "mode indicator lamp" makes a full lighting as in [B.B.] for about 2 seconds after the starter key is turned ON.

◆ 2. System diagnosis

The crane is carrying out system diagnosis while the "mode indicator lamp" is fully lit up.

What is to be checked during system diagnosis is if:

- Electronic circuit in the control box is functioning correctly,
- Manual control lever is at its neutral position, and
- Radio control receiver is connected to the crane and the receiver functions normally.

⚠ CAUTION

★ Do not make a crane operation while system diagnosis is being carried out.

If the crane is operated during the system diagnosis, voice message, "Beep, Service remote control, Service remote control", sounds and the crane is turned into inoperable conditions.

If this happened, depress the reset switch in the control box.

This starts the system diagnosis again.

If it was found normal after the system diagnosis has been completed, the mode indicator lamp lights either one of following indication and voice message, "**Ping-pong, Remote control ready, Remote control ready**", is issued.

Mode	Information	Indication priority
00	Current operation mode is on normal radio remote control mode.	4
0F	Current operation mode is traveling mode.	1
04	Current operation mode is on outrigger radio remote control mode.	2
10	Hook hits against weight for over-winding alarm (over-wound condition).	3

- Since priority is assigned for each mode in its information, it is to be indicated in the order of higher priority.

● Remarks

If the "mode indicator lamp" indicates [04], current control is on outrigger radio control mode.

No crane operation other than extension/retraction of outriggers is possible.

When operating the crane, turn the "crane/outrigger operation mode selector" switch to "crane".

CAUTION

★ If the "mode indicator lamp" fails to make a full lighting during system diagnosis, or voice message, "Beep, Service remote control, Service remote control", is issued despite the fact that the crane has not been operated, take measures according to the section 12. **8** ◆3. "Trouble inspection" (on page 12-39).

5 *How to switch crane operation mode*

The crane can be operated either by manual control levers or by the radio remote control transmitter.

Switch crane operation mode to the manual control mode for operating the crane with manual control lever, and to the radio remote control mode for operating the crane through radio remote control transmitter.

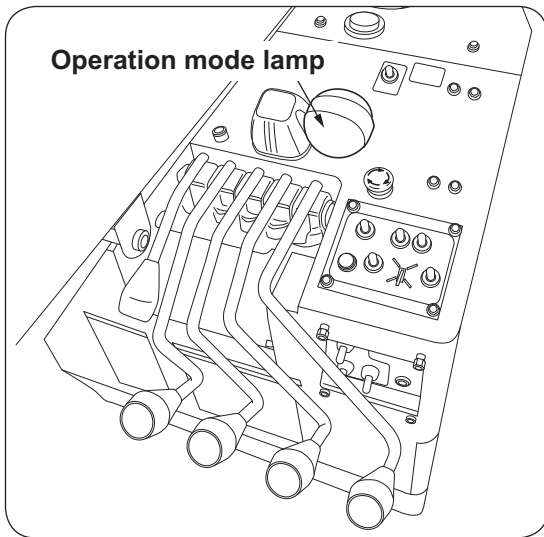

How to switch operation mode

How to switch operation mode

Switching of manual control mode between radio remote control modes is to be made by the radio control selector switch mounted on the cover.

Depression of radio control operation switch when operated on manual operation mode allows to switch it into the radio control operation mode and following voice message is issued:

"Remote control ready, Remote control ready"

The operation mode lamp lights when switched to the radio control operation mode.

Depression of radio control operation switch when operated on the radio remote control mode allows to switch it into the manual operation mode and following voice message is issued:

"Crane mode, Crane mode"

The operation mode lamp goes off when switched to the manual operation mode.

The crane can only be operated via manual control levers when it is on the manual control mode but it cannot be operated through the radio control transmitter.

The crane can only be operated through the radio control transmitter when it is on the radio remote control mode but it cannot be operated via manual control levers (including outriggers).

List of available functions to be operated on each control mode

Crane operation		Operation mode	
		Manual	Radio remote control
Manual lever	Boom Raising/Lowering	○	×
	Hook Hoisting/Lowering	○	×
	Boom Extending/Retracting	○	×
	Slewing C.C.W./C.W.	○	×
	Outrigger Extend/Retract	○	×
Radio remote control transmitter	Boom Raising/Lowering	×	○
	Hook Hoisting/Lowering	×	○
	Boom Extending/Retracting	×	○
	Slewing C.C.W./C.W.	×	○
	Storing hook	×	○
	Mode	×	○
	Speed select	×	○
	Horn	×	○
	Emergency stop	×	○
Engine Start/Stop	—	○	

Operation ○: Possible ×: Impossible

● Remarks

The crane cannot be operated both by manual and by radio remote control without selecting operation mode.

The operation mode is to be memorized even after power to the crane has been turned OFF.

6 How to operate the crane through radio control operation

◆ 1. Preparation before operation

1. Extend the outriggers to their maximum with the manual control lever and level the crane.

- The outriggers are to be controlled on manual operation mode.
If manual mode has not been selected, depress the "radio remote control selector switch" on the switch panel to turn it to be operated on manual mode.

● Remarks

If a crane operation (such as boom Up/Down, hook Up/Down, boom Extend/Retract, and swing C.C.W./C.W.) is carried out while the outriggers are being extended or retracted by manual control lever, the crane will make an automatic stop to avoid dangerous situation.

(The "mode indicator lamp" blinks [□4]. Refer to section "18. Mode indicator lamp" on page 18-1 for detail.)

If this has taken place, stop both operation of the crane and of the outriggers once and try carrying out extension and retraction of outriggers again.

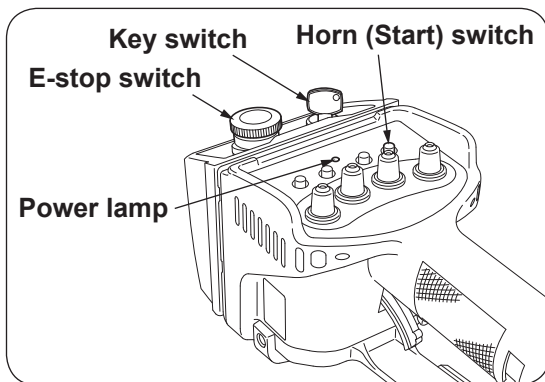

2. Check that the "E-stop switch" on the transmitter has been reset to turn ON the "key switch".

If the "E-stop switch" has not been reset, turn the switch clockwise to reset it.

- Emergency stop function is to be actuated if the "E-stop switch" is pushed in, and emergency stop resets when it is not being depressed.

3. Depression of the "horn (start) switch" on the transmitter energizes the transmitter and "power lamp" lights (in red, in orange, or in green).

- Power to the transmitter is to be turned OFF by pushing in the "E-stop switch", or by turning OFF the "key switch", or if time has passed for more than 5 minutes when no crane operation has been carried out.
- If the "power lamp" blinks or fails to be lit, replace batteries of transmitter according to the section 12. [7] "◆3.How to replace batteries" illustrated on page 12-36.

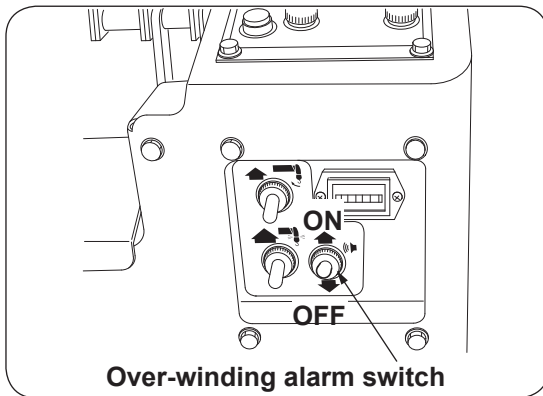

4. Check that the voice switch has been turned ON.
If not, turn it ON.

● Remarks

Voice message will not be issued when the voice switch has been turned OFF.

5. Depress the "radio remote control selector switch" on the switch panel to turn it to be operated on radio remote control mode. The mode indicator lamp indicates [□□] and the following voice message is issued: "Remote control ready, Remote control ready"

- When the operation mode is switched to "radio remote control mode." with power to transmitter turned OFF, the mode indicator lamp indicates [□□]. Turning ON the power to the transmitter allows the mode indicator lamp to indicate [□□].

◆2. How to operate

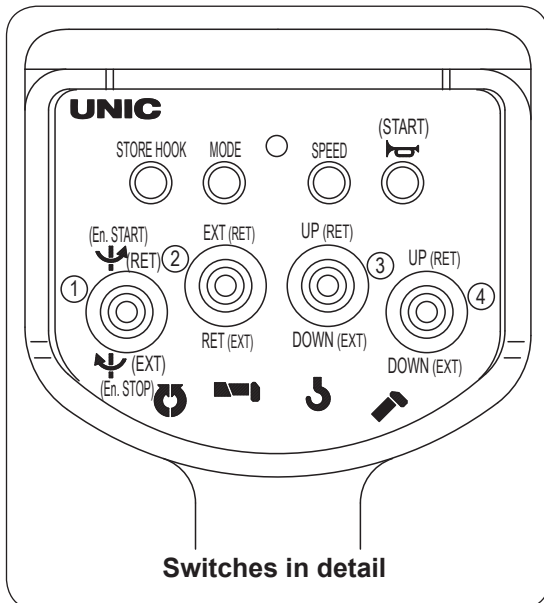
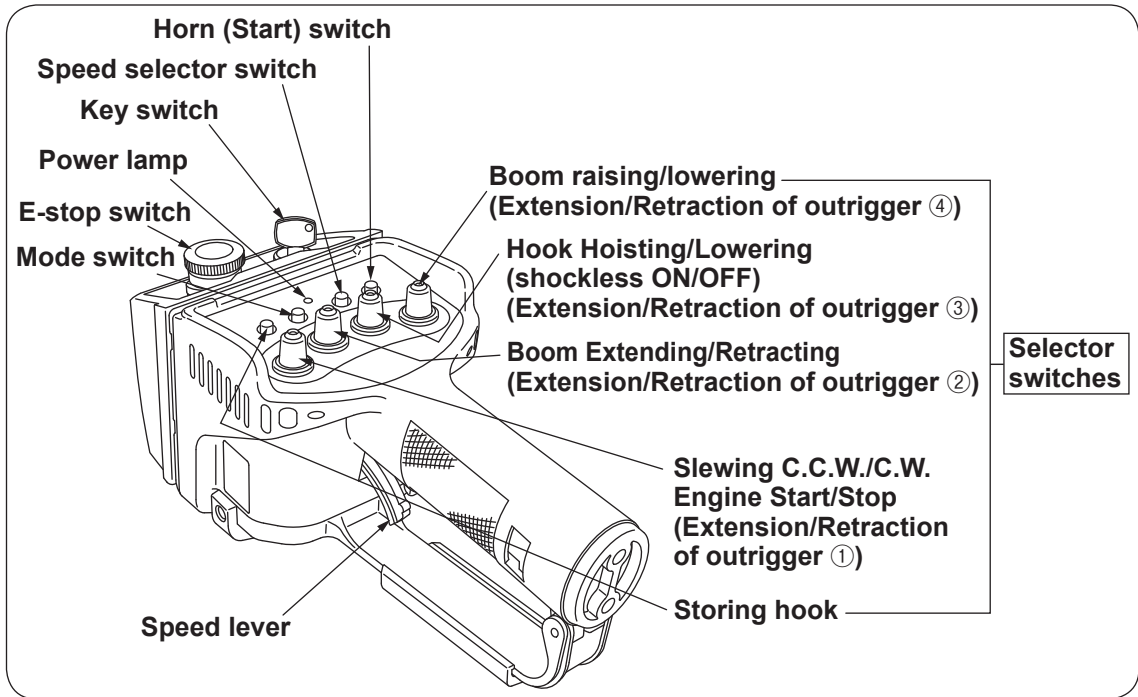

1. Operation of crane function

- (1) Throw a corresponding "selector switch" to the direction allowing the desired crane function.
- (2) Pull the "speed lever" slowly with the "selector switch" remained as it has been thrown.

If only one of the selector switches is to be operated, the crane starts to move slowly with the engine rotated at a low speed (idling speed) when pulling the "speed lever" slowly.

When the speed lever is pulled further, the engine speed increases to allow the operation speed of crane to be faster.

● If the "speed lever" is pulled with more than two "selector switches" thrown, the engine speed becomes faster than that in case of only one of selector switches is being pulled.

(However, maximum engine speed will not change. Refer to section 6 "Engine speed control function" (on page 12-24) for detail.

WARNING

★ When operating the crane with the radio remote control transmitter, be sure not to touch any of manual levers as manual levers shift simultaneously.

- (3) When stopping the crane operation, return the "speed lever" slowly, and then return the "selector switch".
- (4) Depression of the "horn switch" activates the horn on the vehicle.
Use it when calling attention to those who stand around the vehicle.

● **Remarks**

- Switches mounted on the remote controller are ON/OFF type which can be actuated with a light touch.
- Do not apply strong force as it may cause damage to the switches.
- When the same radio wave (of specified small power radiation type radio system) is being used near the working site, response time of the crane it takes from the time when the radio remote control device has been operated may become longer to some extent which is not a fault.
- When operating with the remote controller, working speed may become a bit slower than that of manual operation.

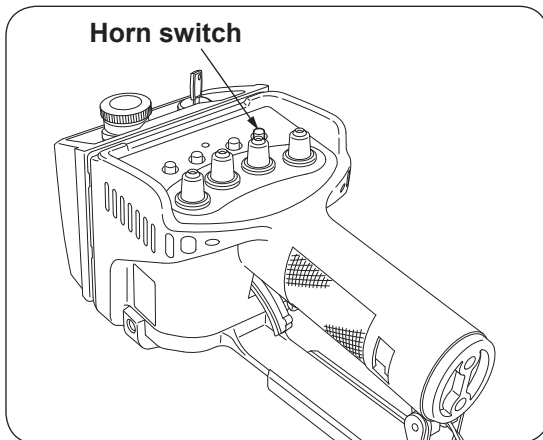

2. How to confirm and change speed mode

When operating the crane with the engine running at a medium speed, or at a lower speed such as in case of working at night, the speed mode can be changed.

(1) How to confirm speed mode

Check the "power lamp" for lighting color, if it is lit in;

- ① Red : High speed mode
- ② Orange : Medium speed mode
- ③ Green : Low speed mode

If the "power lamp" is not lit, turn ON the power to transmitter to light the "power lamp". (Depress the "speed selector switch".)

• Orange illumination is realized by lighting both red and green LED elements.

Red and green LEDs may be seen separately where it is in a lot of sunshine.

(2) How to change speed mode

Confirm that the "power lamp" is lit to depress the "speed selector switch".

Every time the "speed selector switch" is depressed, the "power lamp" lights in the order of



changing speed mode accordingly.

Depression of the "speed selector switch" with the "power lamp" lit in red allows the lamp to light in orange changing it into on medium speed mode.

Depression of the "speed selector switch" with the "power lamp" lit in orange allows the lamp to light in green changing it into on low speed mode.

Depression of the "speed selector switch" with the "power lamp" lit in green allows the lamp to light in red changing it into on high speed mode.

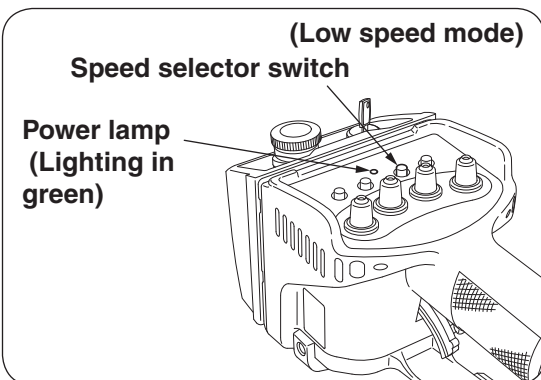
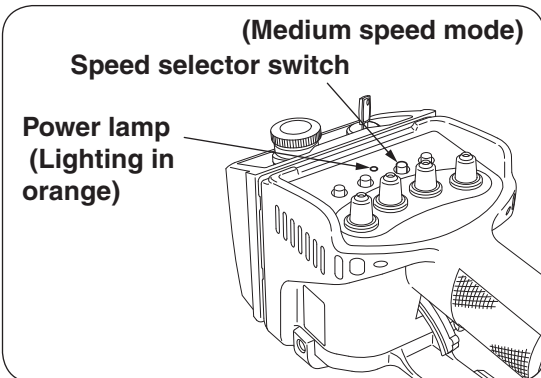
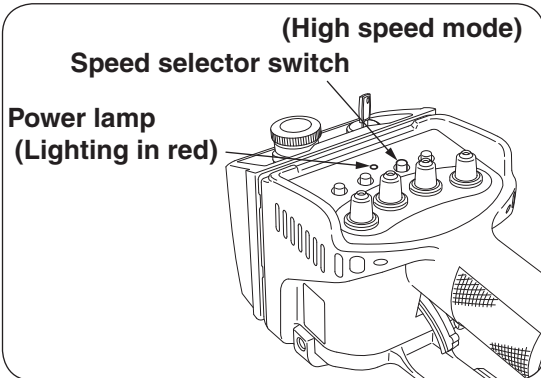

● **Remarks**

Setting of speed mode is to be memorized even when power to transmitter has been turned OFF.

Note that a slight speed difference between slewing C.C.W./C.W. may be found when slewing it on the low speed mode which is not a fault.

(3) Speed mode and manual lever control

Manual lever control is also applied to the speed mode.

High speed mode..... Engine will run at maximum speed.

Medium speed mode Engine will run at medium speed range.

Low speed mode Engine will run at close to idling speed.

● **Remarks**

Speed mode can only be changed through radio control transmitter.

Speed mode switches to high speed mode when power to the crane is turned OFF (starter switch is turned OFF).

Since setting of speed mode is memorized even when power to radio control transmitter has been turned OFF, speed mode is switched to the mode as the radio control transmitter has memorized previously when the crane is operated through radio control transmitter after power to the crane is turned ON again.

3. Interlocking balance control function

When interlocking operation (operation of speed lever with more than 2 of "selector switches" thrown) is carried out through the radio control transmitter, the system equips the function controlling movement of each control lever for each combination of the "selector switches".

Therefore, when the speed lever is pulled to its extreme, movement of each control lever varies in accordance with combination of "selector switches".

In some cases, the control lever may not be shifted to its full extent despite the fact that the speed lever on the radio control transmitter has been fully pulled which is not a fault.

● **Remarks** **On interlocking balance retaining function:**

The crane equips interlocking retaining function which prevent its operating speed from making an abrupt increase when interlocking operation is switched to independent operation,

When operation is switched from interlocking to independent (change from operation of speed lever with more than 2 of "selector switches" thrown to operation of speed lever with one of "selector switches" thrown), control speed may become slower as oppose to that of the independent operation, which is not a fault.

In order to correct this, release all the "selector switches" once and go back to independent operation again.

For immediate returning to normal speed of independent operation when it is switched from interlocking to independent, validity of interlocking balance retaining function can be switched through the transmitter.

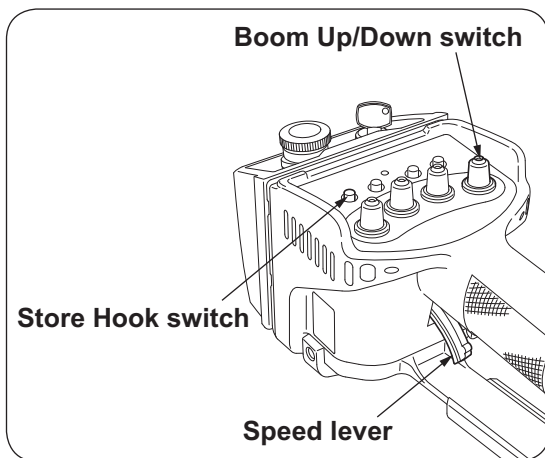

In order for the interlocking balance retaining function to be invalid, depress the "store hook switch" with the "boom Up/Down switch" turned to "Down".

Voice message, "Change control mode, Change control mode", sounds and the interlocking balance retaining function changes to be invalid.

(The voice message does not sound when the function remains as it was.)

Switching condition of the interlocking balance retaining function can be confirmed as the mode indicator is to be lit as in [$\square F$] (meaning "invalid") while the switch is being controlled.

In order for the interlocking balance retaining function to be valid, depress the "store hook switch" with the "boom Up/Down switch" turned to "Up".

Voice message, "Change control mode, Change control mode", sounds and the interlocking balance retaining function changes to be valid.

(The voice message does not sound when the function remains as it was.)

Switching condition of the interlocking balance retaining function can be confirmed as the mode indicator is to be lit as in [□□] (meaning "valid") while the switch is being controlled.



CAUTION

★ Be careful that the operation speed returns to that of independent operation immediately when it is switched from interlocking to independent with the interlocking balance retaining function switched to be invalid.

● Remarks

If the "boom Up/Down switch" is controlled before depression of the "store hook switch", voice message, "Ping-pong, Secure lifting hook, Secure lifting hook", may sounds which is not a fault.

The interlocking balance retaining function switches regardless of sounding voice message.

The interlocking balance retaining function is to be memorized even after power to the crane has been turned OFF.

4. Temporary changing function of interlocking balance (Click operation)

When interlocking operation with 2 "selector switches" thrown (2-interlocking operation) is carried out with the radio control transmitter, each speed balance can be changed temporarily.

Click a "selector switch" for which faster speed is needed during 2-interlocking operation.

Operating speed related to the "clicked" switch becomes faster than that of other operation.

The more number of times a switch has been clicked, the faster the operation related to the clicked switch becomes as opposed to against that of other operation relatively.

Turning OFF both "selector switches" on 2-interlocking operation releases the function to allow them to return to previous conditions.

U-WAVE, Radio remote control device

• Example of operation

Interlocking operation of both "Boom extending" and "Hook Lowering".

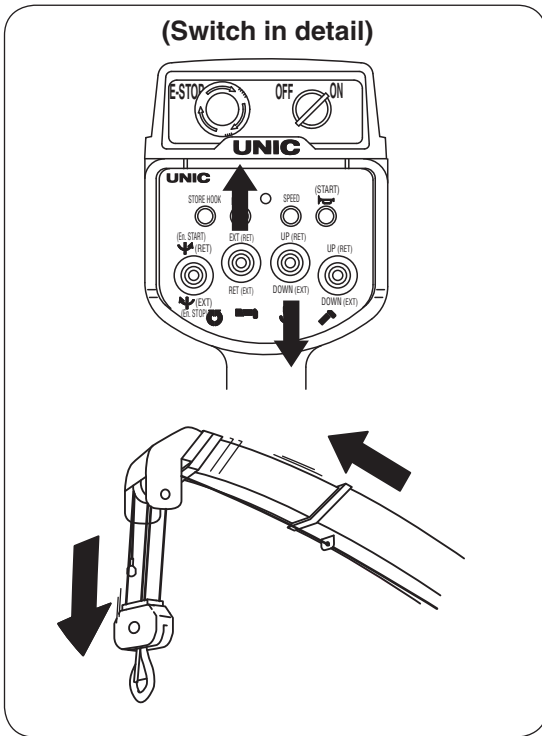

Pull the speed lever with the "hook Up/Down switch" thrown to "Down" and the "Boom Ext/Ret switch" put to "Ext".

The hook lowers and the boom starts to extend.

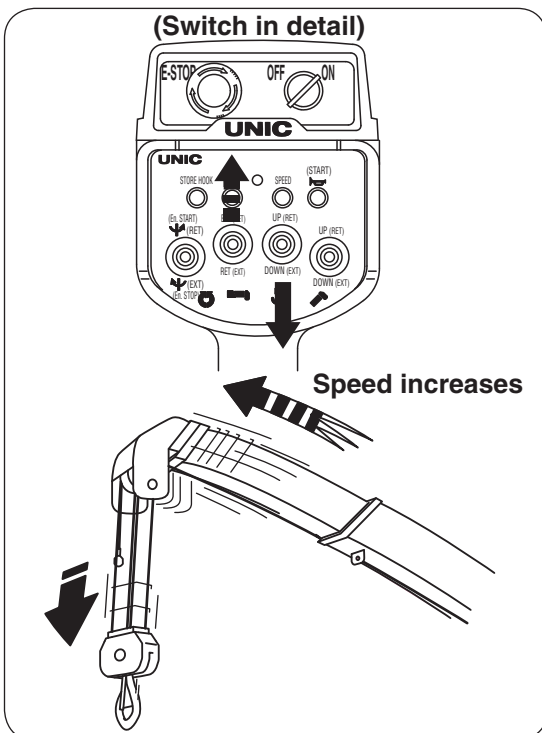

● To increase extending speed of boom
Click (operate it quickly in order of ON→OFF→ON) the "Boom Ext/Ret switch" to "Ext" side.

This allows extending speed of boom to become faster than that of hook down.

The more number of times the switch has been clicked toward "Ext", the faster the boom extension becomes as oppose to that of hook down.

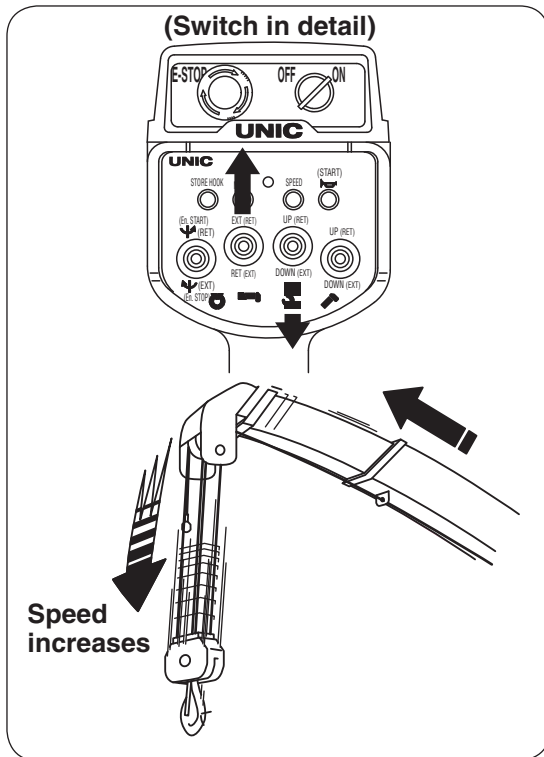

● **To increase winding Down speed of hook**

Click the "hook Up/Down switch" to "Down" side.

This allows the speed of hook down to become faster than that of boom extension.

The more number of times the switch has been clicked for "Down", the faster the speed of winding Down hook becomes as opposed to that of boom extension.

● **Remarks**

- Repeated clicks allow the other operation not to function in the end.
If this happened, release all the "selector switches" once, or click the "selector switch" for which operation is inactivated.
- When one of "selector switches" is released during the clicking operation, speed of crane under operation may become faster.
- The clicking function is possible only when in 2-interlocking operation.
It will not be applied to operation such as of 3-interlocking and 4-interlocking.

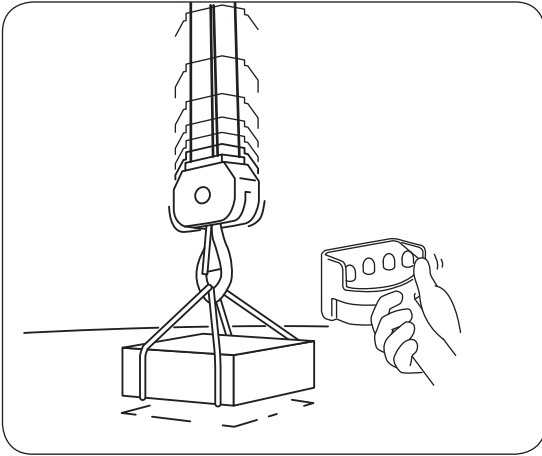

5. Shock-less function

The system equips a "shock-less" function allowing the crane to stop gently even when the crane has been made an abrupt stop by radio control transmitter.

Since the crane will not make an abrupt stop against a sharp operation, it eases shock to the crane and/or to the mounted vehicle, and it is also effective to prevent the wire rope from jumping up and a lifted cargo from swinging when the hook has stopped winding-up.



CAUTION

★ Pay attention that the crane makes a slight movement due to shock-less function after the radio control operation has been stopped abruptly.

● Remarks

When making the crane a sudden stop:

If the crane has to be made a sudden stop, actuate the "selector switch" controlling opposite function while the shock-less is functioning.

(Do not pull the speed lever in this case.)

Otherwise, the shock-less function is released to allow the crane to make a sudden stop.

When canceling the shock-less function:

If the shock-less function is unnecessary, it can be activated/inactivated by the radio control transmitter.

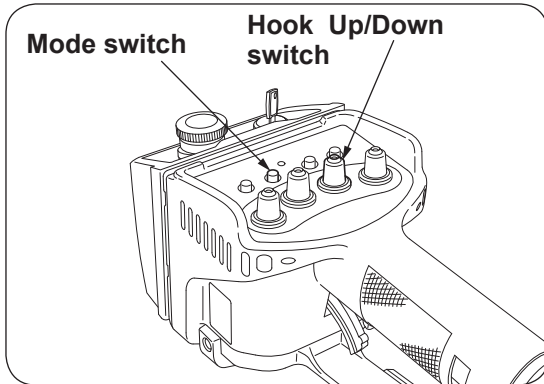

In order to inactivate the shock-less function, throw the "hook Up/Down switch" to "Down" with the "mode switch" depressed. The shock-less will not be functioning.

In order to activate the shock-less function, throw the "hook Up/Down switch" to "Up" with the "mode switch" depressed. The shock-less starts functioning.

When the shock-less function is active and the "mode indicator lamp" shows any of [00], [01], [04], [06] [07], switching it to be inactive allows the figure indicated on the left to change to [-].

Switching the shock-less function to be active allows the mark [-] indicated on the left to change to [0].

Mode display	
When shock-less function active:	When shock-less function inactive:
00	-0
01	-1
04	-4
06	-6
07	-7

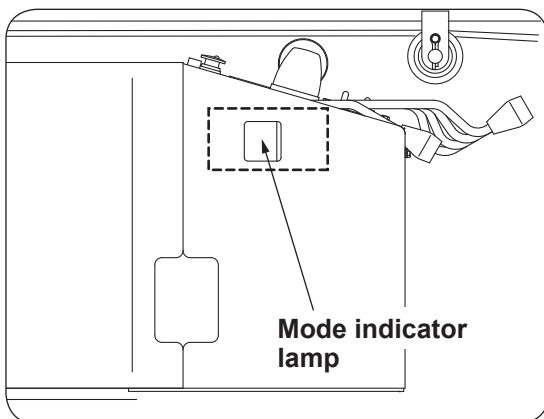

CAUTION

★ Be sure to check if the mode indicator changes accordingly after the shock-less function has been switched.

● Remarks

When the mode indicator shows [10] (over-wound condition), no change happens even after the shock-less function has been switched.

When checking condition of the shock-less function, remove the over-wound condition by operation of lowering hook or retracting boom.

Setting of shock-less function is to be memorized after power to the crane has been turned OFF.

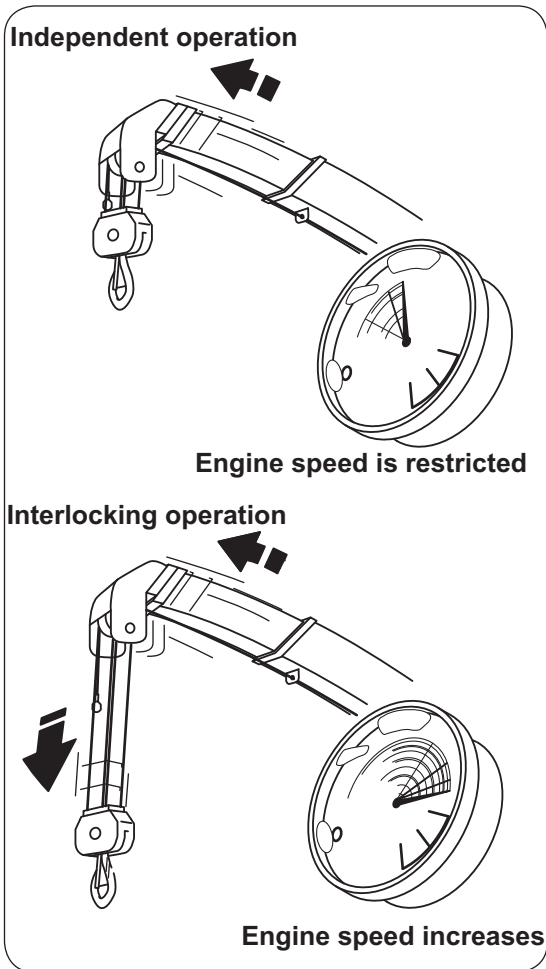

6. Engine speed control function

The system equips a function controlling the engine running at a suitable speed according to operating condition of the crane.

The function helps save energy because it can ease temperature rise of hydraulic oil and restrict the unnecessary increase of engine speed by controlling the engine to run at an appropriate speed.

- On independent crane operation, it allows the engine speed not to be increased unnecessarily while the crane is operating functions such as lowering boom, retracting boom, swing C.C.W./C.W., and retracting outriggers.
- The engine speed increases when the crane operation has been switched from independent to interlocking. (But no change in maximum engine speed.)
- The engine runs at a medium speed while the outriggers are being extended and retracted.
- When swinging the crane on independent operation by controlling manual lever, swinging speed may become faster when the independent operation is switched to interlocking operation by controlling other one of levers.
This is not a fault.

◆3. How to store hook

! WARNING

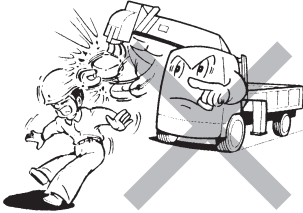

★ Since releasing the hook from its stored position allows it to swing, it may cause an accident if a person stands under or in front of the hook.

In addition, excessive pulling of the “speed lever” increases the hook to swing that is dangerous so that do not pull the lever extremely.

★ It is strictly prohibited to operate the crane with the “storing hook” as this is very dangerous.

★ Retract the boom fully and lower it to its extreme to store it.

★ Do not operate the “storing hook” with any one of control levers at the same time.

This may cause an incorrect action and/or a breakdown of the crane.

★ Pay attention that the manual control lever for “hook Up/Down” moves “Up” side when retracting the hook.

U-WAVE, Radio remote control device

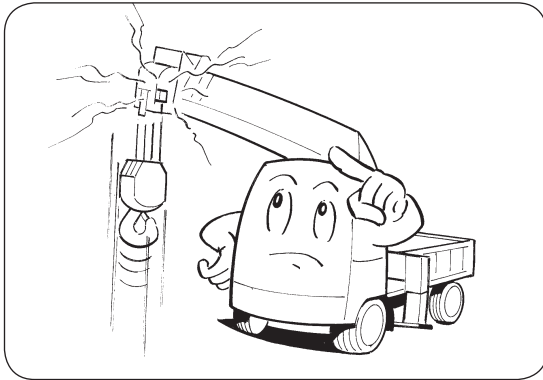
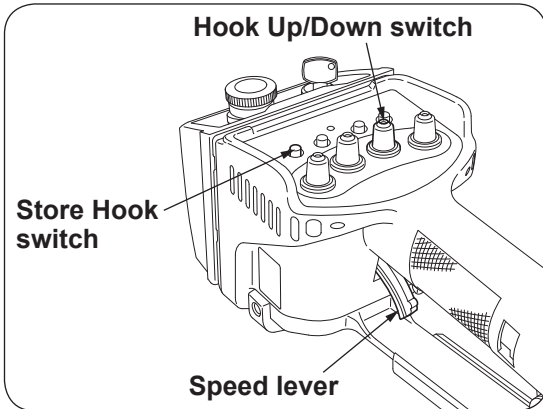

- (1) Wind up the hook with the "hook Up/Down" of selector switches.

The hook stops being wound-up automatically when it hits against the weight for over-winding alarm.

- When it stops being wound-up, following voice message, "**Beep, Stop winch up, Stop winch up, Beep, Beep**" is issued.

The last part of voice message, "**Beep, Beep**", stops sounding when the operation concerned has been stopped.

- (2) Depress the "store hook switch" after the hook is at a standstill.

- Following voice message, "**Ping-pong, Secure lifting hook, Secure lifting hook**" is issued.

- (3) When pulling the "speed lever" with the "store hook switch" depressed, the hook starts being wound up slowly.

The "mode indicator lamp" indicates [] while the hook is being stored.



CAUTION

★ Storing the hook while it is swinging may cause damage to the boom, to the hook itself, and to the wire rope.

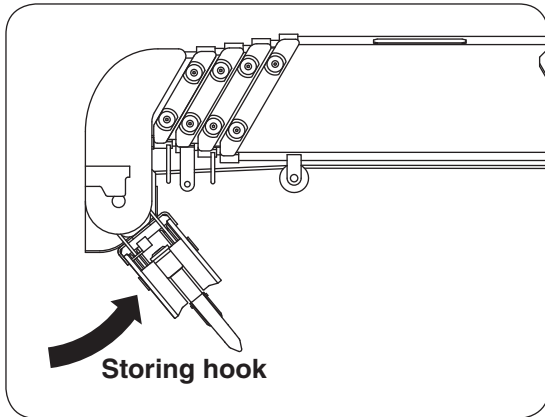

(4)

■ **URW295CP1UR**

The hook hits against the guide on the boom top to be stored in position

Storing hook operation stops when the "speed lever" is returned and then the "store hook switch" is returned.



CAUTION

★ If the hook hits against the guide on the boom top obliquely or it is off the guide halfway, wind-down the hook to try storing operation again.

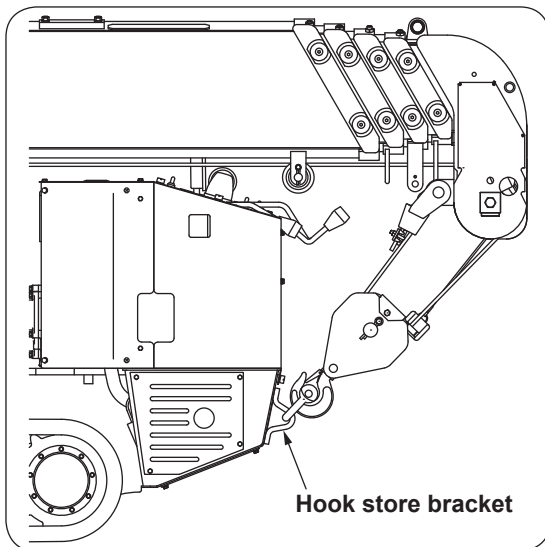

■ **URW295SCP1UR**

Put the hook on the storing bracket to wind it up slowly by the "store hook switch".

Release the switch after the hook has been stored.

● **Remarks**

The engine is still running at a low speed (idling) while the hook is being stored.

◆4. How to operate outriggers

Crane operation mode and outrigger operation mode can also be switched from radio control transmitter.

1.Preparation before operation

When the selector switch is thrown to "Outrigger" the outrigger mode indicator lamp located on the cover lights and the mode is switched to outrigger operation mode.

Indication of "mode indicator lamp" changes to [04] and [05], and voice message, "Change control mode", is issued.

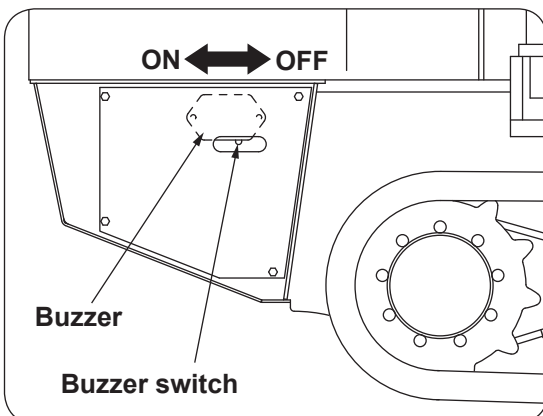
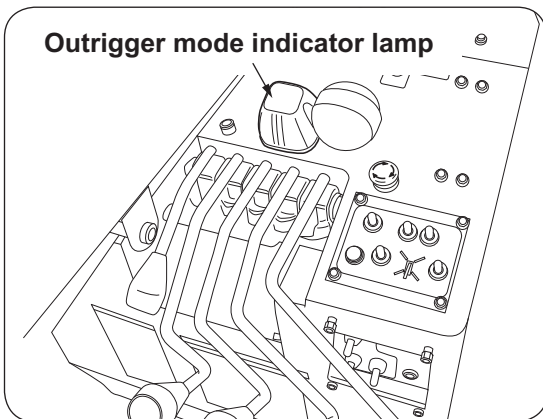
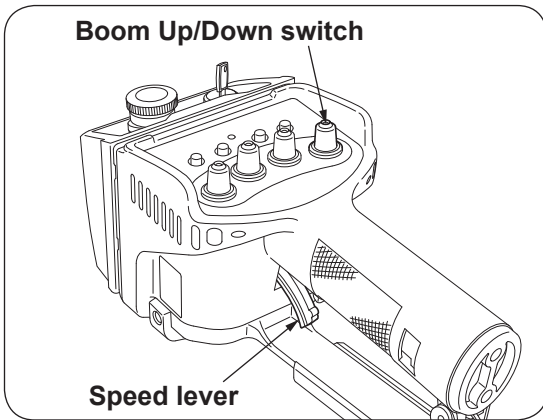

● Remarks

Turning OFF switch on the buzzer to stop the alarm sound.

If alarm sound of buzzer is to be avoided such as in working at night, turn it OFF to stop the buzzer.

Turn it ON when in normal crane operation.

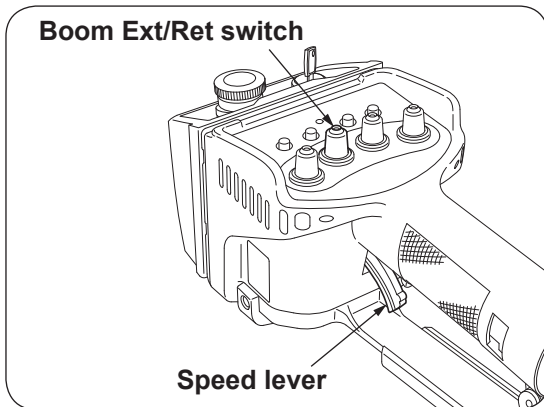

2.Operation

Throw the "selector switch" corresponding to the outrigger number requiring control to the desired operation side.

Then pull the "speed lever" slowly while keeping the "selector switch" thrown to the desired operation.

As the "speed lever" is pulled slowly, the vertical cylinder starts to be operated gradually with the engine running at a low (idling) speed, and pulling it further allows operating speed of the vertical cylinder becomes faster as the engine speed is increased.

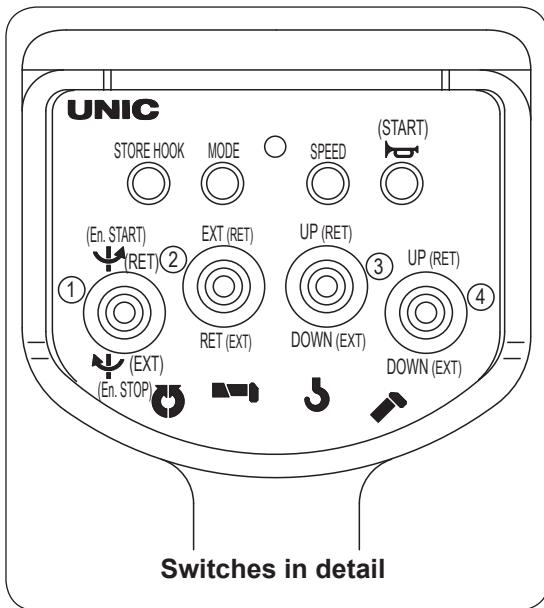

To extend

Turn the switch to "Ext" to pull the "speed lever".

To retract

Turn the switch to "Ret" to pull the "speed lever".

To stop

Return the "selector switch" after the "speed lever" has been returned slowly.

● Remarks

When the "crane/outrigger operation mode selector switch" is turned to "outrigger" (outrigger mode indicator lamp is being lit), normal crane operation of "boom Up/Down", "hook Up/Down", "telescoping boom", "slewing C.C.W./C.W.", and "storing hook" to be impossible both in radio control transmitter and in manual control lever.

When the selector switch is thrown to "crane" voice message, "Change control mode", is issued and the mode is switched to crane operation mode when the yellow lamp located on the cover goes off.

CAUTION

★ If it has been selected to the mode (operation) to which is going to be selected, voice message will not be issued.

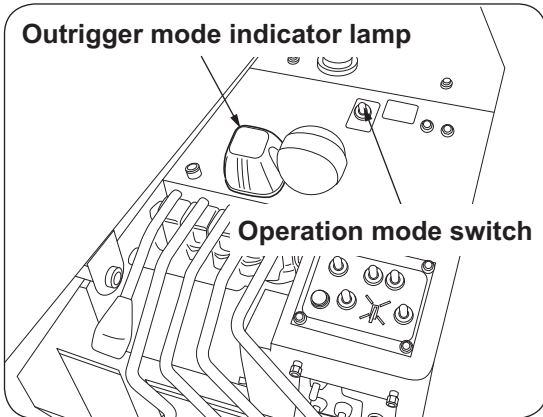

3. Closing operation

When extending/retracting operation of outrigger through the radio control transmitter has been over, be sure to turn the "crane/outrigger operation mode selector switch" to "crane".

The outrigger mode indicator lamp goes off and the buzzer stop sounding.

Indication of the "mode indicator lamp" changes to either one of [00], [01], [06], or [07], and voice message, "Change control mode", is issued.

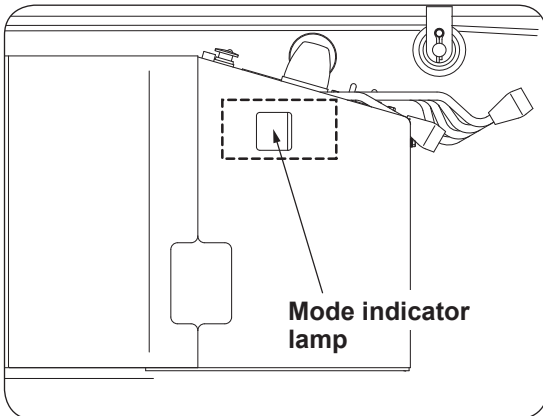

(Refer to section 18. ① "Mode indicator lamp" (on page 18-1) for mode indication in detail.

CAUTION

★ Take special care that your foot will not be stamped by outrigger while extending outriggers.

★ Be sure to secure the hook in place while outriggers are being operated.

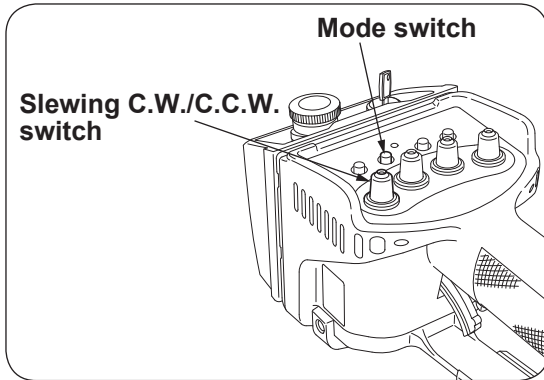

◆5. Starting/Stopping engine

The engine can be started and stopped from the radio control transmitter.

- ① When the engine key is turned ON, turning the selector switch to "slewing C.C.W." with the "mode switch" being depressed allows the engine to start.
- ② Turning the selector switch to "slewing C.W." with the "mode switch" being depressed allows the engine to stop.

⚠ CAUTION

★ When the engine is to be stopped for a long period of time, be sure to turn OFF the engine key on the side of crane.

If the engine is being stopped by radio control transmitter for a long time during which power to transmitter is turned ON, shortening the life of batteries results.

★ The radio control system carries out system diagnosis automatically every time when power is turned ON.

★ Do not operate the crane while the system diagnosis is being carried out.

(Do not touch any one of switches and levers during this period.)

If the crane is operated during system diagnosis, voice message, "Beep, Service remote control, Service remote control", sounds and the crane is turned into inoperable conditions.

If this happened, depress the reset switch in the control box to carry out system diagnosis again.

★ If the voice message, "Beep, Service remote control, Service remote control", is issued when turning ON the power despite the fact that the crane has not been operated, ask a UNIC authorized service shop for repair as failure in the radio control system is suspected.

◆6. How to operate when engine speed becomes unstable due to low temperature

When in winter season or when temperature is too low, the engine speed may become unstable as viscosity of hydraulic oil increases.

In this case, switch the system to "low temperature operation mode" to allow the engine speed to be stable.

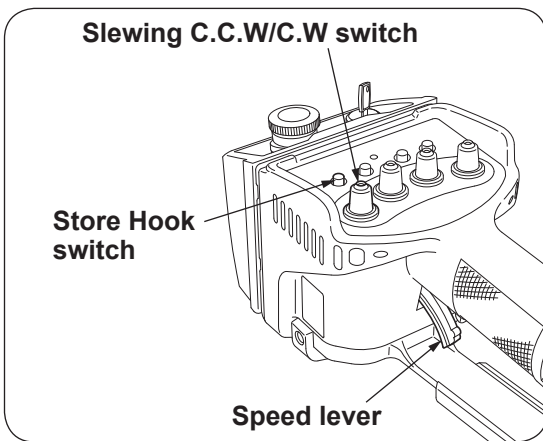

1. Switching to low temperature operation mode

Depress the "store hook switch" with the "swing C.C.W./C.W." switch turned to "C.C.W.".

Indication of the "mode indicator lamp" changes to [06], and voice message, "**Ping-pong, Change control mode, Change control mode**", is issued.

(Indication will not change if the "mode indicator lamp" is showing [04], [05], or [10].)

● Remarks

When switching it to low temperature operation mode, operation of the "store hook switch" before the "swing C.C.W./C.W." selector switch has been actuated may allow voice message, "**Ping-pong, Secure lifting hook, Secure lifting hook**", to be issued.

2. Resetting low temperature operation mode

Depress the "store hook switch" with the "swing C.C.W./C.W. switch" turned to "C.W.". Indication of "mode indicator lamp" changes to [] and voice message "**Ping-pong, Change control mode, Change control mode**", is issued.

(Indication will not change if the "mode indicator" is showing [], [], or [].)

In addition, the low temperature operation mode is to be reset automatically, even when operation illustrated above has not been carried out, after approx. 10 minutes from the time when it has been switched to the "low temperature operation mode".

The voice message "**Ping-pong, Change control mode, Change control mode**", is issued at this time.

● Remarks

Response of the crane functions becomes slower when operated on low temperature operation mode.

In normal case, operate the crane after warming-up for a while to raise temperature of hydraulic oil.

Under extreme low temperature, crane operation may still be unstable even after the system has been switched to the "low temperature operation mode".

In this case take measures such as by carrying out warm-up operation to raise temperature of hydraulic oil or by using hydraulic oil suitable for extreme low temperature.



CAUTION

★ If viscosity of hydraulic oil is too high at a low temperature, excessive load will be imposed on hydraulic pumps which may cause damage to them.

In order to avoid this, be sure to carry out warming-up to raise temperature of hydraulic oil to an appropriate temperature to operate the crane.

◆7. Closing crane operation

After completion of the crane work, turn OFF the starter switch to shut off power to the crane after the boom, the hook, and the outriggers have been stored in their respective positions.

7 How to replace batteries of transmitter

◆1. When to replace batteries

⚠ CAUTION

★ When the power lamp of transmitter starts blinking, replace the batteries as early as possible. Leaving them as they were may cause the liquid in the batteries to leak.

★ In case where leakage of battery liquid is found, wipe it off the battery holder and the battery case thoroughly to put new batteries in it.

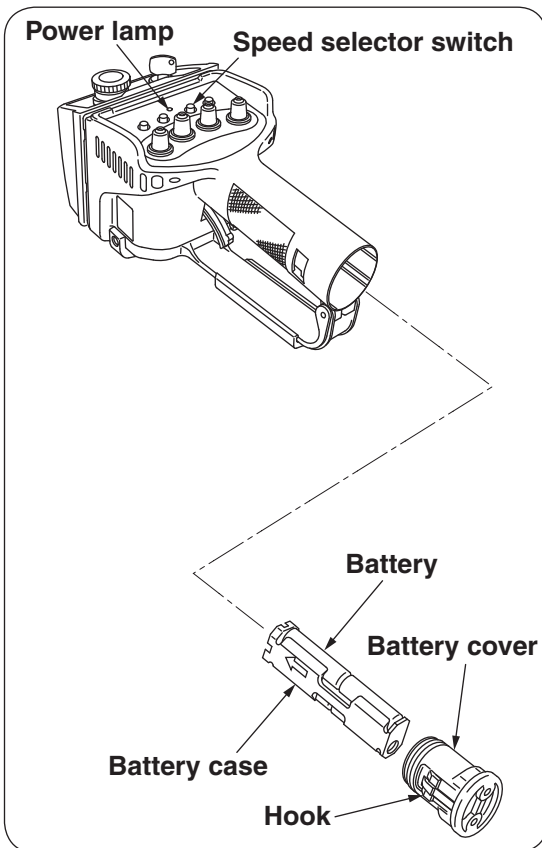

● Check the "power lamp" for lighting with the "speed selector switch" on the transmitter depressed.

- ① Continuous lighting: Radio control transmitter can be used.
- ② Blinking in low frequency (a flash every second): It allows the radio control transmitter to be used for about 1 hour after the blinking has started. Replace the batteries as early as possible as they are close to running out.
- ③ Blinking in high frequency (a flash every 0.1 second): The radio control transmitter can not to be used as the batteries have run out.
- ④ No lighting: The radio control transmitter can not to be used as the batteries have completely run out.

● If the "power lamp" blinks slow as in the state of ② above, following voice message, "Ping-pong, Low transmitter battery, Low transmitter battery", is issued.

The trouble lamp on the receiver blinks in red, and the "mode indicator lamp" indicates [99] in blinking.

◆ **2. Battery to be employed**

a size AAA battery: 4 pieces

Use alkaline-type battery.

(Manganese-type battery has a short service life.)

● **Remarks**

About the use of rechargeable batteries

Although UNIC recommends the use of alkaline type battery in the radio control transmitter, other rechargeable batteries such as nickel-hydrogen type and nickel-cadmium type may also be used.

Pay attention to the following when a rechargeable battery is used:

- Message suggesting replacement of battery may not be issued.
Be sure to prepare alkaline-type batteries when operating the crane through radio remote control device because rechargeable batteries tend to become inoperable suddenly.
- In some cases, service life of rechargeable battery may become shorter than that of alkaline battery in accordance with the capacity.
- There is a disadvantage such as memory effect comparing with alkaline-type battery.



CAUTION

★ **Do not mix up batteries of old and new, of different manufacturers, or of different types.**

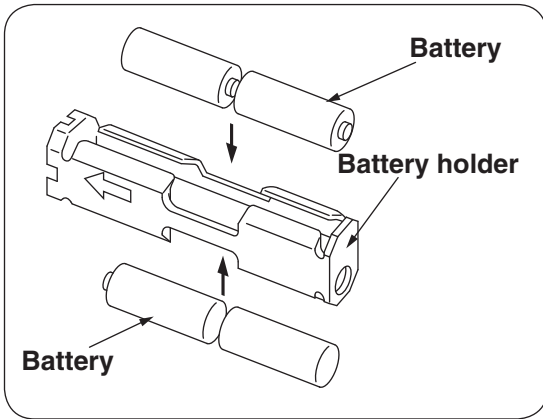

◆ 3. How to replace batteries

- (1) Turn OFF power to the crane (Turn OFF the starter switch.).
- (2) Pull out the battery cover with the hook on the cover pushed in.
- (3) Replace old batteries in the battery holder with new ones.



CAUTION

★ Pay attention to polarity of batteries.

(Put them as indicated on the battery holder)

★ Do not connect between terminals of (+) and (-) directly with a metal piece.

- (4) Insert the battery holder into the transmitter grip to tighten up the battery cover securely.



CAUTION

★ Take care that a drop of water will not enter inside of the grip.

- (5) Depress the "speed selector switch" to check that the "power lamp" lights.

● Remarks

Unless to the power to crane is turned OFF once when replacing batteries, blinking indication of [99] on the mode indicator lamp will not goes off even after batteries have been replaced.

8 Daily checks, trouble inspection

◆1. Daily checks

For cranes with radio remote control device, you are requested to inspect your crane for following items as well as carry out daily checks on your crane (read operator's manual of UNIC crane concerned for detail).

Check that;

- 1.** Each enclosure of transmitter, receiver, and control box has not been damaged.
If the enclosure has been damaged, repair it immediately because moisture and/or dust entered through the break may cause a failure to electronic parts inside and cause incorrect operation of the crane concerned.
- 2.** The stay on the transmitter has not been broken or deformed.
The transmitting antenna is built in the stay.
If break or remarkable deformation is found in the stay, replace or repair it as soon as possible because it may cause radio interference.
- 3.** Switches and control levers on the radio control transmitter make a smooth operation.
Using the remote control transmitter with dust, dirt, and mud being stuck on may lead to failure especially in operation of switches and/or control levers.
Wipe them off with a piece of cloth after use.
If any of the selector switches fails to function correctly due to contamination, ask a UNIC authorized service shop for cleaning.



CAUTION

★ Never try disassembly or alteration of the transmitter, the receiver, and the control box.

★ Electric system is very sensitive to moisture.

Do not wash the transmitter, the receiver, and the control box with water directly.

◆2. Check lamps (Radio control receiver)

Check lamps are mounted on the radio receiver, and they light as follows when it is in normal operating condition:

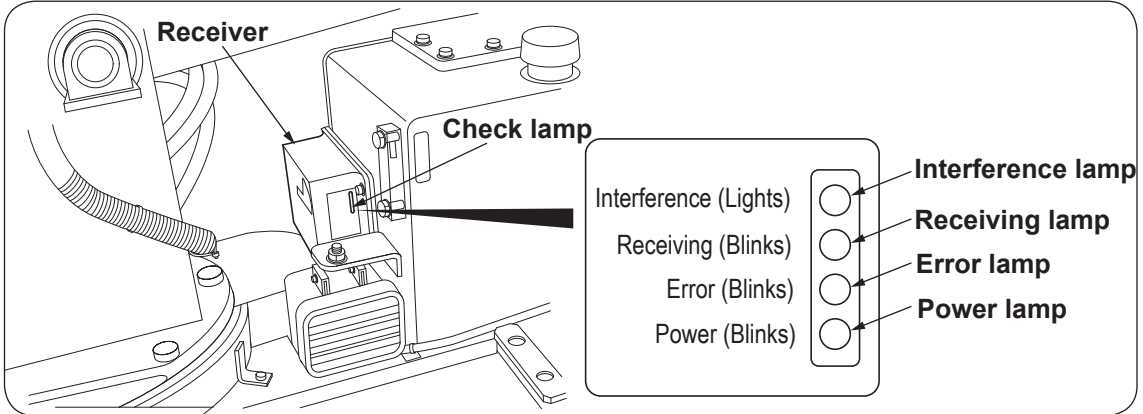

● Power lamp

When energizing the crane by turning ON the starter switch, it blinks in green.

● Receiving lamp

When the receiver is received radio wave transmitted from the transmitter correctly, it blinks in green.

● Interference lamp

If it lights in red when power to the transmitter is turned OFF, it indicates that the receiver is receiving radio wave from outside.

If it lights in red when power to the transmitter is turned OFF, response time during radio control operation may become longer to a certain extent.

When radio control operation is initiated from the state where the power to transmitter is turned OFF, the "interference lamp" may light for a moment but it is not a fault.

● Error lamp

It blinks in red when something is wrong with the radio control transmitter/receiver.

It also blinks in red when batteries in the transmitter have been run out.

◆3. Trouble inspection

If a trouble is found in the radio remote control device, check the following then contact the nearest UNIC authorized service shop.

Check if:

- ① Crane is controlled by manual levers.
- ② The "power lamp" on the transmitter lights. If it blinks or does not light, replace the batteries in the transmitter.
- ③ Switches and control levers on the transmitter make a correct operation.
- ④ The stay on the transmitter (antenna is built in) has not been broken or deformed.
- ⑤ The "mode indicator lamp" in the control box lights and the "power lamp" on the receiver blinks in green when power to the control box is turned ON.
If the "mode indicator lamp" blinks, refer to section "18. Mode indicator lamp" (on page18-1).

If the "error lamp" on the receiver blinks in red, turn OFF the power once and turn it ON again (turn ON the starter switch again).

If blinking of "error lamp" persists, repair is needed as the radio remote control device is in failure.

◆4. How to make an emergency stop

In case of emergency such as that the crane does not stop operation or the engine will not return to idling speed even if no crane operation has been made, depress the "Emergency stop switch" on the switch panel.

This makes the crane and the engine to stop operation forcibly.

⚠ WARNING

★ When releasing the "Emergency stop switch", release it while no crane operation is being carried out.

Releasing the "Emergency stop switch" while operating the crane allows the crane to make an abrupt movement that is very dangerous.

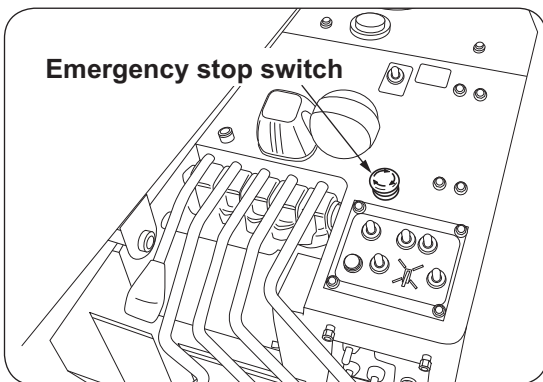

● How to make an emergency stop for the crane and reset it

Depress the "Emergency stop switch" on the switch panel of crane body.

The switch is held pushed in allowing the engine to stop operation.

When the switch is held pushed in, the engine cannot be re-started.

Rotate the "Emergency stop switch" clockwise in arrow direction to return to its original state to release the switch.

● Remarks

When the emergency stop is reset by turning the "Emergency stop switch" clockwise after the crane has been stopped by depression of "Emergency stop switch", the engine speed may increase in a moment which is not abnormal.

When the crane is operated with the "Emergency stop switch" held pushed in, voice message, "Beep. Service remote Service remote control" may be issued or the mode indicator lamp may show incorrect indication.

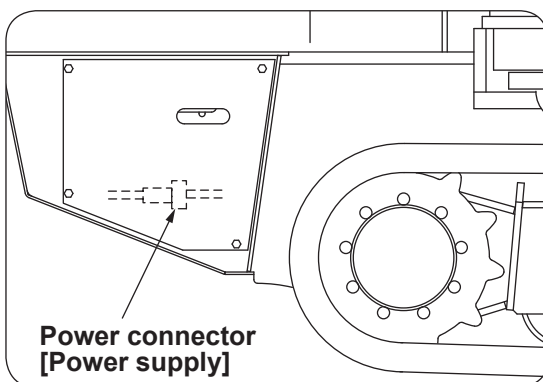
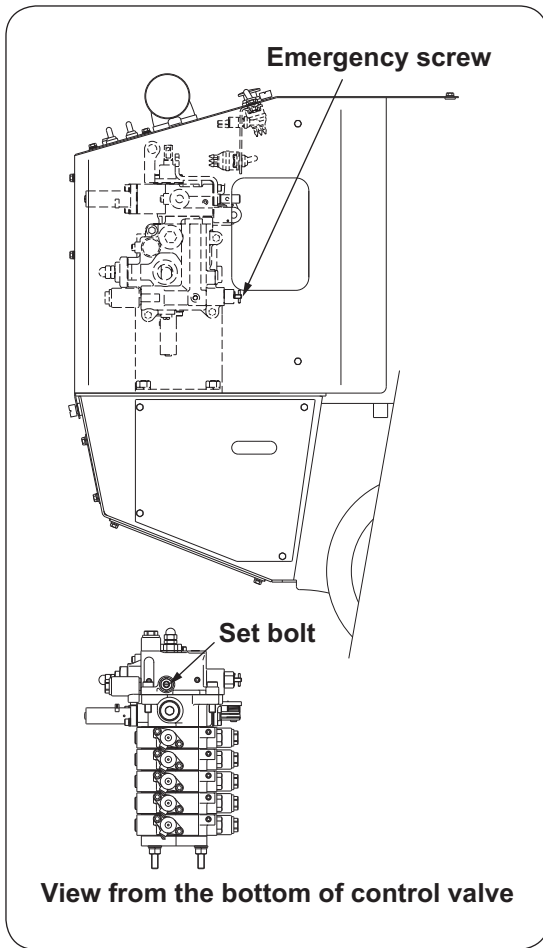

◆5. Operation in an emergency

If the crane fails to be operated either by radio remote control or by manual control, operate the crane by taking procedures as follows:

Procedure

- ① Remove the lock pin attached to the emergency screw and gently turn the emergency screw clockwise until tight.
(Pay attention that the screw may break if it is tightened with an excessive force.)
- ② Check that all manual control levers are at their neutral positions.
If a lever has been caught in halfway, return it to its neutral position.
- ③ Disconnect the power connector [BATTERY MAIN] located under the control valve.
- ④ Loosen the hexagon nut attached to the lower part of the control valve and then tighten the locked set bolt until tight.
This allows the crane to be operated.

CAUTION

★ Be sure to tighten up the set bolt after the emergency screw has been tightened.

If the set bolt has been tightened up without tightening the emergency screw, the crane may make an abrupt movement.

★ In this situation, safety devices such as engine speed control, voice message, and automatic stop are not functioning so that careful operation is needed.

★ Since this is a measure when in an emergency, be sure to repair the crane at an authorized UNIC service shop after it has been stored.

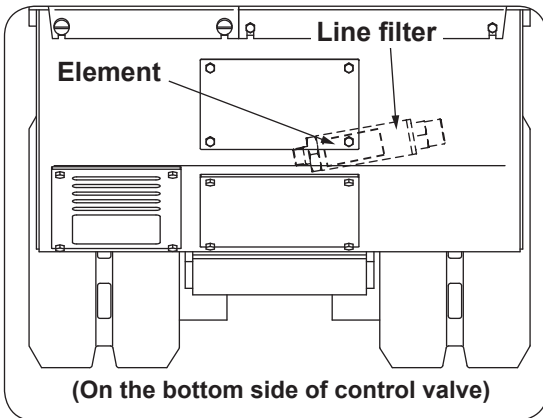

◆6. Replacement of line filter element

Replace the element inside of line filter after 1 year from the start of operation.

Be sure also to replace the element when the hydraulic pump is replaced and replace it after 1 year from the start of operation of the pump.

13. MAINTENANCE AND INSPECTION OF CARRIER

WARNING

★ **Caution signboard**

Be sure to hang a “caution signboard” such as on control levers while either maintenance or inspection is being carried out, and do not try operating the crane.

★ **Be sure to replace consumable items according to the replacement criteria.**

Failure to observe the replacement as specified may cause a breakdown and warranty will not be given even if it is within the period to be applied.

★ **When a part needs to be replaced or anything abnormal is found, contact a UNIC service shop for consultation or for inspection or ask repair as soon as possible.**

1 Inspection before operation

 WARNING

★ Since the machine uses gasoline as fuel, check the hose for crack and connections for tightness if you have a smell of gasoline around the engine.

If fuel leaked in the vicinity of engine and muffler which are very hot may cause a fire.

Wipe it off completely.

★ Be sure to stop the engine, and store the boom and the outriggers before carrying out maintenance and inspection.

★ A fire source such as smoking cigarette in mouth is strictly prohibited.

★ Do not start maintenance and inspection immediately after the engine has been stopped.

Carry it out after the engine and the heated parts have been cooled down.

In order to secure safety in crane operation and to improve working efficiency, be sure to inspect each part of the carrier according to the table as follows:

Device	Servicing item	Device	Servicing item
Engine	Fuel leakage Remaining fuel quantity Engine oil quantity/Filling up Battery electrolytic solution level check Unusual vibration, Noise Loose bolt, Broken bolt	Hydraulic oil tank	Oil leakage, Oil quantity, Filling up
		Interlock for crane-crawl lever	Function
		Crawling lever	Slack, Travel
		Wheel sprocket	Loose bolt
		Rubber crawler	Crack, Damage, Tension
		Frame	Bend, Crack, Deformation
		Truck roller	Loose nut, Oil leakage

 CAUTION

★ Perform monthly and annual inspection according to “Voluntary inspection table” in the warranty which is provided separately.

★ Keep the crawler crane in good condition so that it will be always ready for normal operation.

◆1. Check for remaining fuel quantity
/ Draining water

! WARNING

★ Fuel (gasoline) is highly inflammable.

Do not smoke and bring a fire source close to the fuel when refueling and draining sediment.

★ Wipe up spilled fuel thoroughly after refueling as it may cause the fire.

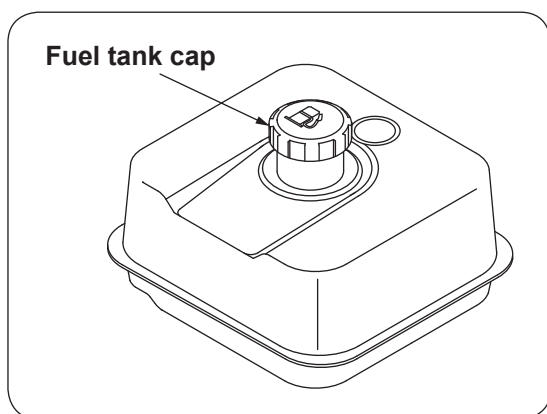

- When refueling, remove the cap and never fail to put the strainer of fuel tank in order to prevent water and dust from entering the tank.

Fuel tank capacity: 1.6 gal. (6 liters)

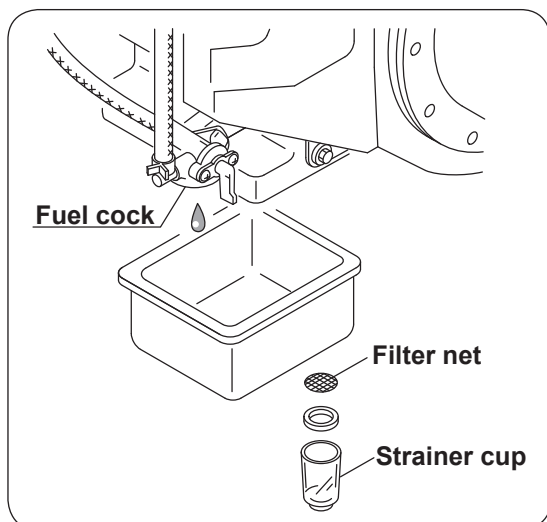

- When draining fuel in order to transport the crane and store it for long period of time, remove the strainer cup in the fuel cock to extract it.

- In addition, clean up the filter net with the fuel strainer cup removed.

**◆2. Check for engine oil quantity /
Filling up/Change**

⚠ WARNING

- ★ Wipe up spilled oil thoroughly after filling it up as it may cause the fire.
- ★ Do not check and change the engine oil while it is still hot.

⚠ CAUTION

- ★ Replace engine oil after 25 hours of operation for initial replacement, and after every 50-hour operation thereafter.

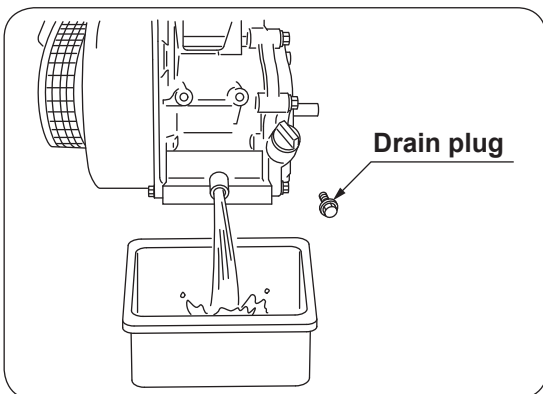
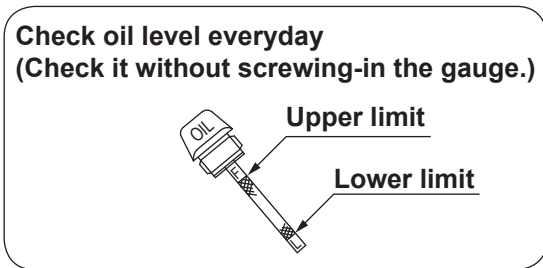
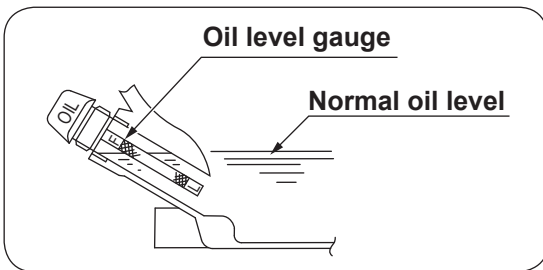

Check engine oil quantity before starting the engine with the crawler crane parked on a flat ground.

If the engine has been started, stop the engine and wait at least more than 5 minutes to check the oil level.

- Extract the oil level gauge and wipe it off with a piece of clean rag. Insert the gauge fully again then extract it slowly to check the level gauge to find where it is wetted with oil. (Check the oil for contamination and viscosity at the same time.)
- If engine oil level is found too low, supply it from the filling port.
Oil quantity to be filled up: 0.3 gal. (1.2 liters)

◆3. Check for battery electrolytic solution level / Filling up

! WARNING

★ Gas evaporated from the battery solution is inflammable. Do not bring a fire source close to the battery during a battery maintenance.

And, be sure to disconnect the negative (-) side of battery cord.

★ Battery electrolytic solution contains sulfuric acid so that you may be blinded or burned by the solution when your eye, skin, or clothes was stained with the solution.

Wear safety goggles and rubber gloves as a protective measures when working at battery.

If the solution stuck to your skin or clothes, wash it away with plenty of water immediately.

In case where it entered into your eye accidentally, see a doctor for treatment.

★ When the crane will not be operated for a long period of time such as in being stored, charge the battery as follows:

Warm season	Once a month
Cold season	Once every 2nd month

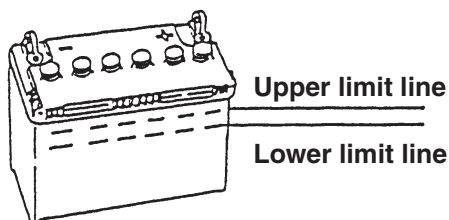

- Check that the battery solution level is somewhere between the upper and the lower limit lines with the battery placed level.
- If solution level is found below the lower limit line, remove the cap to fill it up with distilled water (It is available at a gas station.) Tighten the caps securely after the water has been filled.
- Pay attention that the crane body may be eroded by the battery solution due to leakage during operation if solution level exceeds beyond the upper limit line.

◆4. Check hydraulic oil tank for oil level / Filling up

⚠ WARNING

★ Since temperature on the hydraulic oil tank surface is too high immediately after operation, remove the cap of the filling port after the temperature has gone down.

⚠ CAUTION

★ Replace hydraulic oil for the first time after 3 months of operation, and every year or every 500 hours of operation thereafter.

★ Clean up the suction strainer and the return-filter once a year.

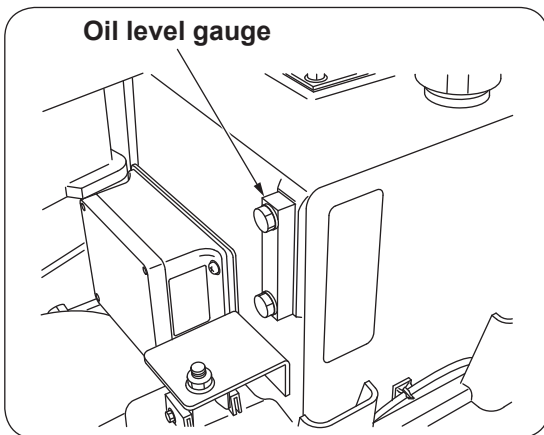

- Park the crawler on a flat ground to stop the engine.
- Check the oil quantity at the oil level gauge located in front of oil tank.
Capacity of hydraulic oil tank: 7.1 gal. (27 liters)

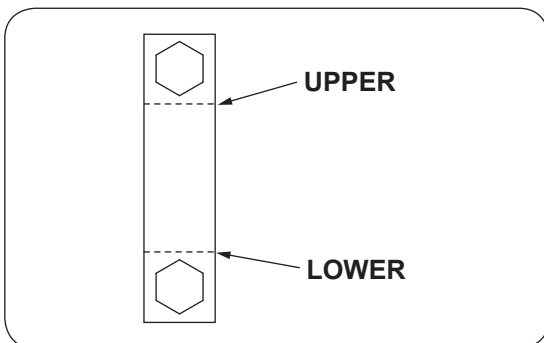

- A proper quantity of hydraulic oil is somewhere between "UPPER" and "LOWER" limits as illustrated in the figure.
- If oil level is found below the "LOWER" limit, remove the cover to the tank and remove the cap to fill it up with a specified oil.

◆7. Check for rubber crawler / Adjustment

! WARNING

★ Do not check rubber crawler tension with the crane body raised above the ground.
It is very dangerous because an accidental fall of the crane may happen during inspection.
Be sure to carry out tension check with the crane touched the ground.

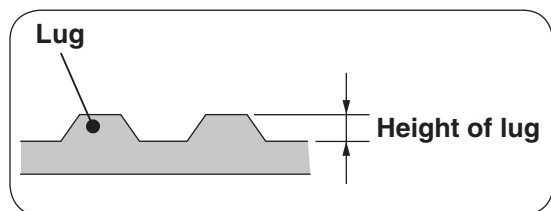
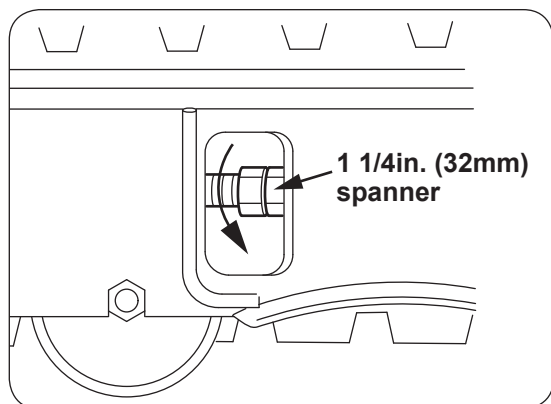
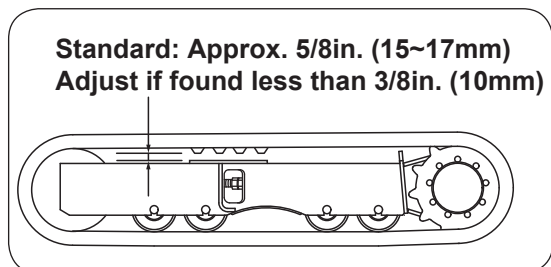

■ Inspection/Adjustment

Check the rubber crawler for wear and for tension whenever necessary as the wear varies according to operating and ground conditions.

- Initial check/adjustment: After 30 hours of operation and whenever necessary.
- When tensioning the rubber crawler, turn the nut following the arrow direction as illustrated and lock it with another nut (double-nut system).
- If the tension is too tight, it shortens service life of rubber crawler, wheel sprocket, and idle roller.
- Replace the rubber crawler when the lug height becomes less than 1/8 in (3 mm).

! CAUTION

★ Adjust the tension again after 30 hours of operation if the new rubber crawler has been mounted.



CAUTION

- ★ Do not crawl over lying rocks or stones with sharp edges.
- ★ Do not change direction where there is a difference in ground level.
- ★ Do not make a quick change of direction as it may cause the wheels to go off the rubber crawler.
- ★ Do not operate the crane on a ground being heated to the temperature of more than 140°F (60°C.)
- ★ Do not stain the rubber crawler with oils such as fuel, hydraulic oil, grease, and the other oil.
- ★ Do not operate the crane at a place where salt content is abundant.
- ★ When storing the crane for long period of time, store it indoors where it will not be exposed to the ray of the sun or to the rain directly.

2 Inspection and Maintenance which is to be carried out every 250 hours or 3 months

◆1. Check/Cleaning of air cleaner element

! WARNING

★ Do not make a cleaning and a replacement of air cleaner while engine is running.

! CAUTION

★ If the crane is operated in dusty environment, shorten the time when making inspection and cleaning accordingly.

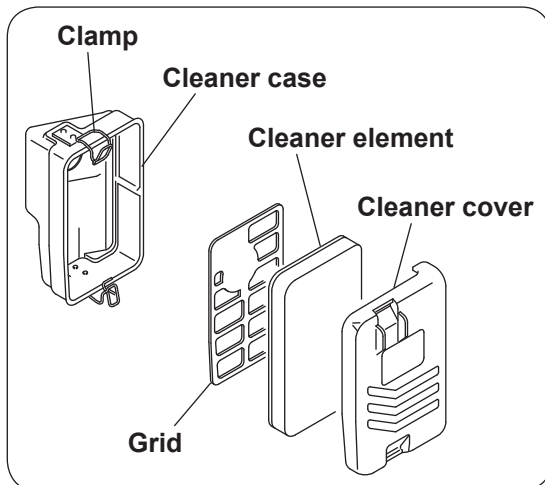

Check and clean the air cleaner element when the crane has been operated for 250 hours (3 months).

- 1** Unfasten the clamps to remove the air cleaner cover.
- 2** Clean the air cleaner element.

**◆2. Check oil quantity in the reduction gears of crawling motor/Filling up
(Change oil every 1,000 hours)**

! WARNING

★ Do not rush to work as each section of crawling devices is heated to a high temperature immediately after the crane operation.

Work after temperature of crawling devices have gone down.

★ Pressure may be remained inside of the reduction gears of crawling motor.

Unfasten the filling port plug by 2~3 turns slowly to release the internal pressure and then remove the plug.

An abrupt removal of the plug may cause the plug to pop out or the oil to spurt out which is dangerous.

Do not turn your body or face toward the plug.

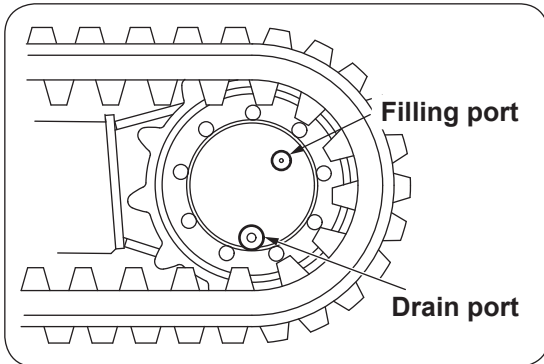

1 Park the crane on a flat ground.

2 Position 2 (two) plugs at the end of reduction gears of crawling motor as illustrated in the figure, "position for inspection", and stop the engine.

3 Unfasten the filling port plug slowly to bleed air.

4 Remove the filling port plug and oil quantity is correct if oil flows out of the filling port.

If oil quantity is insufficient, fill it with the oil specified.

5 Check the sealing of each plug, replace it with new seal if it is found damaged.

6 Put the plug on the filling port and tighten it.

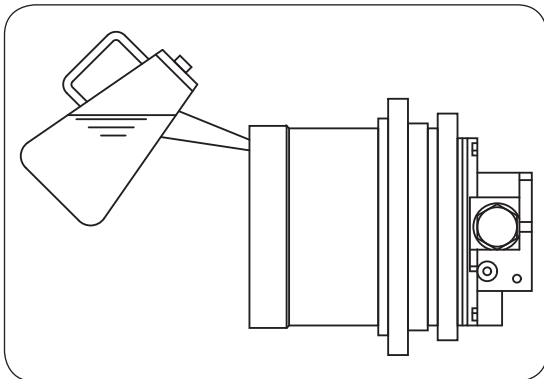

3 Storage

WARNING

★ Stop the engine and thoroughly remove dirt and dust stuck on the carrier body.

In particular, be sure to remove the dust stuck to the battery, electric wiring, and the members directly affected by engine heat such as muffler as it may cause a fire.

★ In order to prevent those who are not in charge such as children from access to the crane, cover the crane or store it in a storage house.

Cover the crane after all the heated parts in the crane have been cooled down, otherwise it may cause a fire.

★ Shift each crawling lever at its neutral position.

★ If ambient temperature is expected to go below the freezing point, drain the water in radiator or add an anti-freezing fluid to the water to prevent it from freezing.

★ Avoid storing the crane more than 3 months at a place where it is likely to be exposed to the direct sun light as the crawler made of rubber.

★ Disconnect a negative(-) side of battery cable if the crane is to be stored for a long period of time.

Failure to do this may cause a fire due to short-circuited such as by biting of a rat.

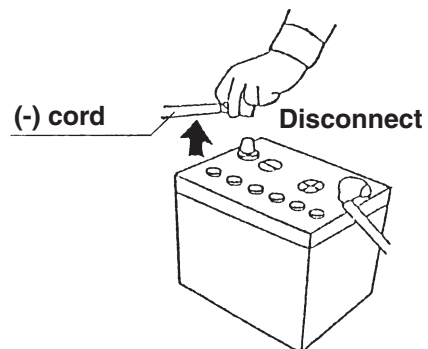

4 *Fitting safety covers*

WARNING

★ Be sure to fit the safety covers removed during inspection and maintenance where they were fitted originally.

Otherwise, it is very dangerous because uncovered rotating members and heated parts may cause injury.

5 *Maintenance and inspection of engine*

Carry out the maintenance and inspection of engine according to "Instruction manual for engine".

14. MAINTENANCE AND INSPECTION OF CRANE



WARNING

★ **Caution signboard**

Be sure to hang a “caution signboard” such as on control levers while either maintenance or inspection is being carried out, and do not try operating the crane.

★ **Be sure to replace consumable items according to the replacement criteria.**

Failure to observe the replacement as specified may cause a breakdown and warranty will not be given even if it is within the period to be applied.

★ **When a part needs to be replaced or anything abnormal is found, contact a UNIC service shop for consultation or for ask inspection or repair as soon as possible.**

1 Inspection before operation

In order to secure safe operation and improve working efficiency, be sure to inspect daily each part of the crane according to the table as follows:

Device	Servicing item	Device	Servicing item	Device	Servicing item
Pump	Tightness of each mounting Oil leakage Unusual noise	Hook	Rotation of hook Function of retaining mechanism	Frame	Mounting of crane body Cracks Tightness of bolts Missing bolt
Hydraulic oil tank	Oil level Oil leakage	Wire rope	Damage Condition of rope-end	Slinging implements	Items necessary for crane operation are provided
Outriggers	Natural descent Function Control lever return Deformation Damage Oil leakage Cracks	Overwinding alarm	Function Alarm sound	Automatic storing device for hook	Function of automatic stop and storing operation
	Hoisting winch	Interlock for crane-crawl lever	Check that crane will not actuate on crawling, and crawler will not travel on crawl lever return and on crane operation.	Automatic stop for leaving minimum wire rope	Further unwinding stops automatically when remaining wire rope on the drum comes to 3 turns.
Slewing device	Function Control lever return Oil leakage	Load meter	Oil leakage Function	turnover prevention device	Refer to page 9-11 Inspection before starting operation Daily inspection Trouble inspection Alarm inspection Inspection for automatic stop Check wiring for damage Check sensor mounting for tightness
Derricking boom	Function Control lever return Oil leakage Mounting of foot-pin	Warning horn	Function		
Telescoping boom	Function Control lever return Oil leakage Deformation Cracks Mounting of fixing pin	Piping, Hydraulic hose	Oil leakage Damage	Searcher hook (UR295 CP1UR only)	Function Deformation Cracks Mounting of fixing pin
		EXT. JIB (UR295 CP1UR only)	Function Deformation Cracks Mounting of fixing pin		

 **CAUTION**

★ Perform monthly and annual inspection according to “Voluntary inspection table” in the warranty which is provided separately.

★ Keep the crawler crane in good condition so that it will be always ready for normal operation.

2 *Cleaning*

Keep the crane clean at any time.

Sands and fine dusts may cause an abnormal wear .

Do not wash the crane by splashing highly pressurized water to prevent it from entering into the electric system by which may cause malfunction of the crane.

3 *Inspection of bolts mounting slewing bearings*

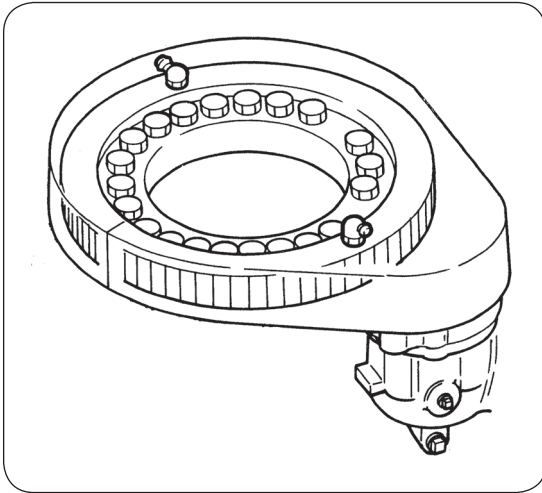

When the slewing device makes an unusual noise while operating or crawling the crane, or when a gap is created on the mounting surface, contact a UNIC authorized service shop for inspection and/ for repair.



CAUTION

★ **Break of the bolts mounting slewing bearings may invite an accident such as overturn and destruction of the crane. Check the mounting bolts (outer ring side) for tightness once every 6 months.**

4 Replacement of wire rope (for winding-up)

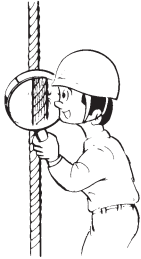

Wire rope is an expendable article and it will be damaged and its strand wires are broken to allow it to be thinner through a long period of operation.

Replace the rope according to following criteria.

◆1. Replacement criteria

1.A rope in which amount of broken strand wires (except filler wires) comes to more than 10% within a pitch of twist.

Replace the wire ropes intended for use with this crane if 13 pieces of strand wire have been broken within a pitch of twist.

2.A rope being kinked.

3.A rope from which its diameter has decreased by more than 7% of the nominal diameter.

For example, if wire rope with a nominal diameter of 5/16in.(8mm) is used, replace it when the diameter becomes 0.29in.(7.5mm).

Refer to the section 17. MAJOR SPECIFICATIONS, for length and construction of the wire rope for winding-up.

4.A rope which has been deformed and/or corroded excessively.

★ **Be sure to replace a wire rope when it comes under the criteria, item 1 through 4, illustrated above.**

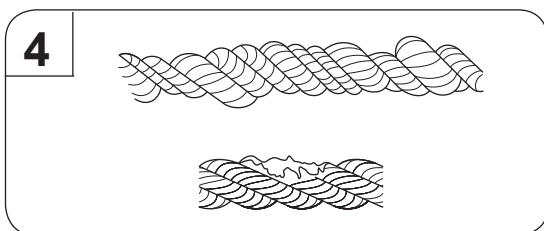
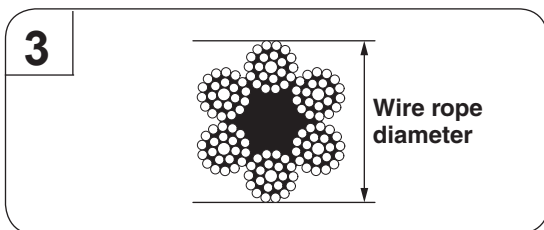
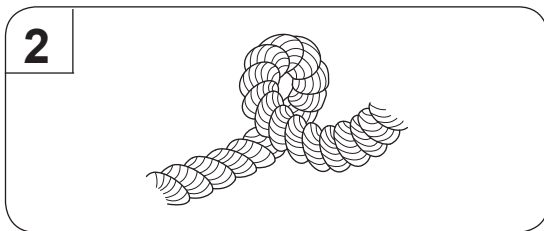
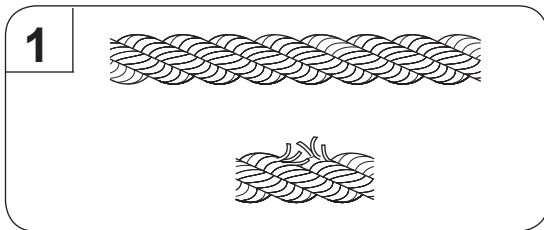

CAUTION

★ **Wear leather gloves when replacing wire ropes.**

◆2. How to replace wire ropes

■ URW295CPIUR

1. Refer to the figure in the left for how to hook the wire ropes for winding -up and for where the weight for over-winding alarm is to be mounted.

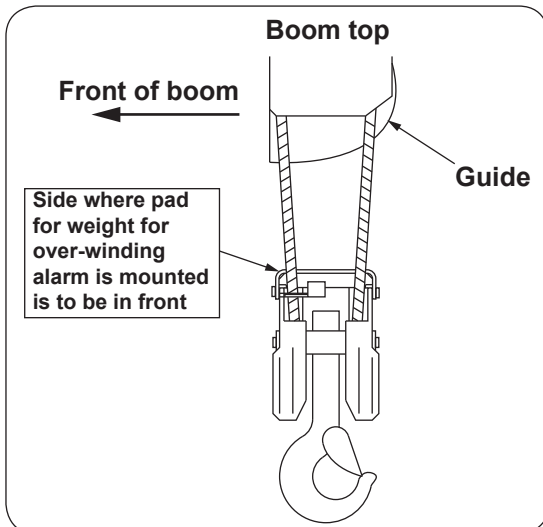
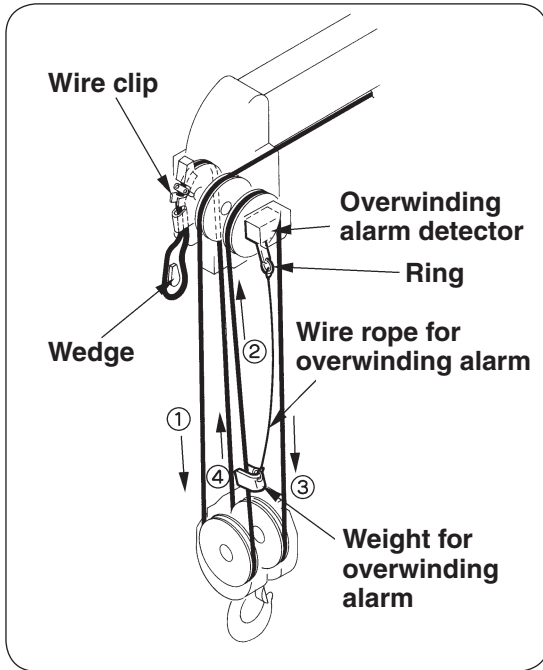

Refer to the figure in the left for how to attach the hook.

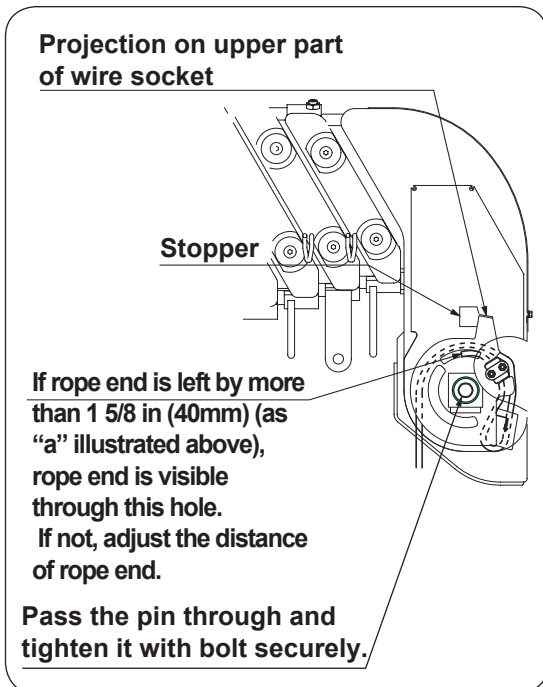
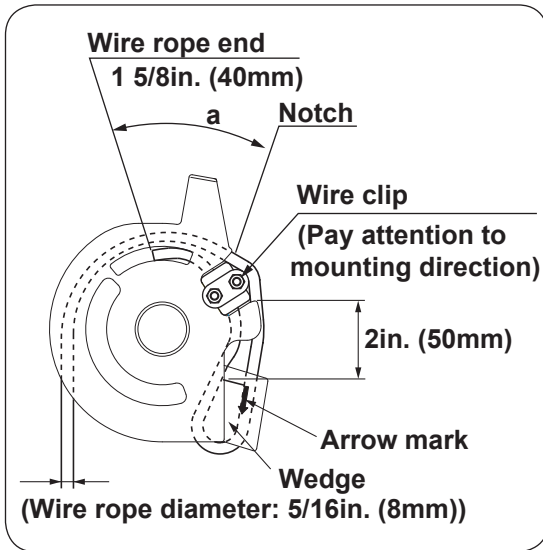

2. How to fix wire rope end

① When passing the wire rope end through the wire socket, be sure to pass it as indicated by the arrow mark on the socket.

If it is passed from the opposite direction, service life of wire rope becomes shorter as the wire rope is kept bent all the time.

② Do not forget to mount the wedge and the wire clip as illustrated in the figure in the left. Leave the wire rope end to allow a distance from the notch to the rope end by more than 40mm as illustrated in the figure as "a".

③ Pass the pin through with the wire socket held with your hand and tighten it with the bolt securely.

■ **URW295SCP1UR**

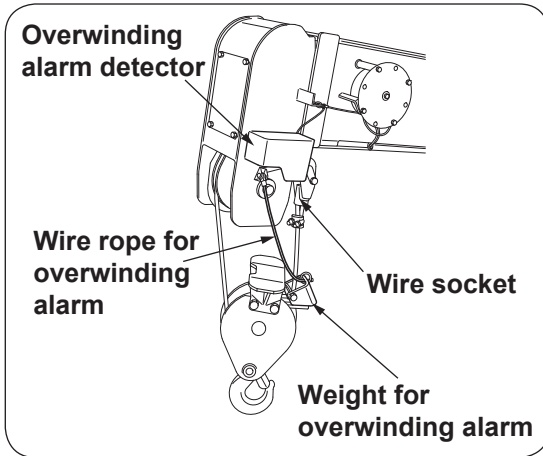

1. Refer to the figure in the left for how to hook the wire ropes for winding -up and for where the weight for over-winding alarm is to be mounted.

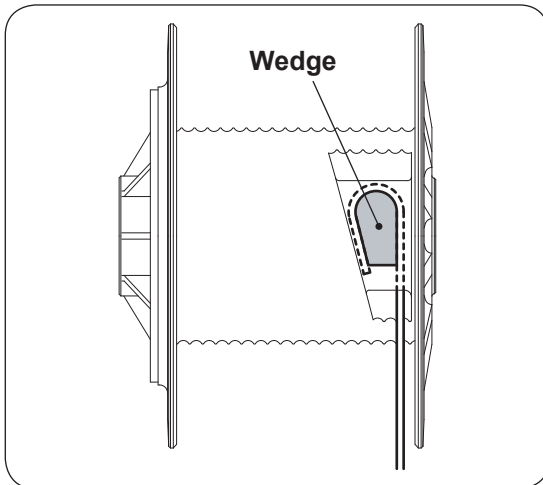

Refer to the figure in the left for how to attach the hook.

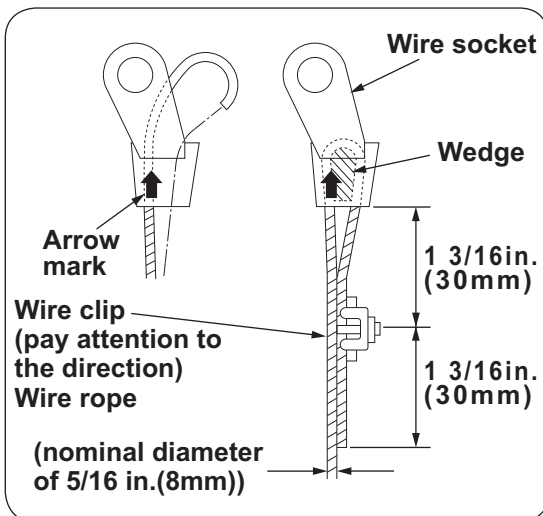

2. How to fasten the end of wire rope

- ① When passing the wire rope, pass it along the arrow mark indicated on the wire socket. If it has been passed in the opposite direction, service life of the wire rope is shortened as it is kept bent all the time.
- ② Be sure to attach both the wedge and the wire clip as indicated in the figure .on the left.

MAINTENANCE AND INSPECTION OF CRANE

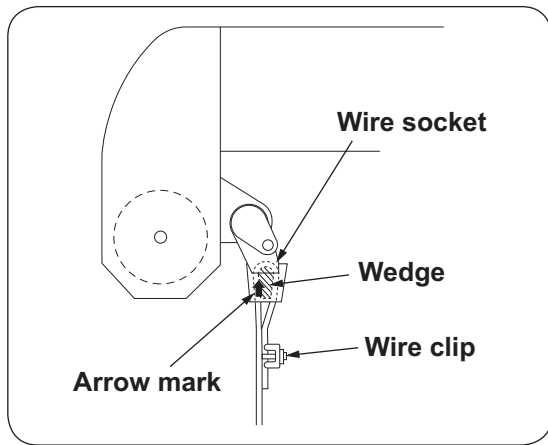

- ③ When mounting the wire socket to the boom, the arrow mark indicated on the wire socket comes outside as in the figure on the left.

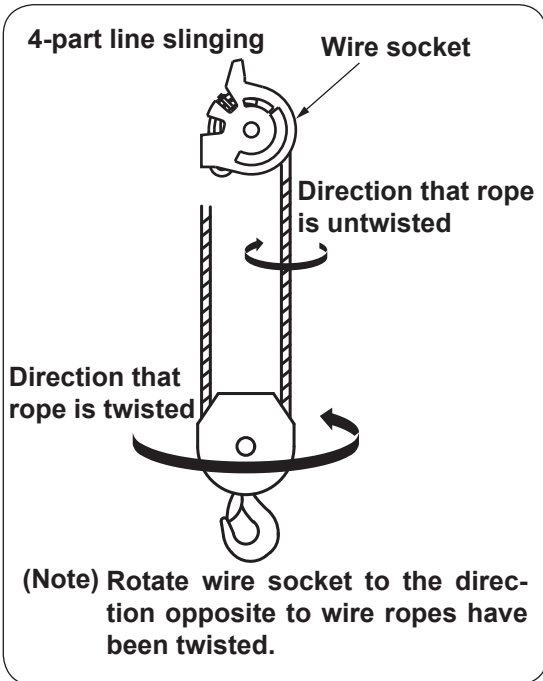
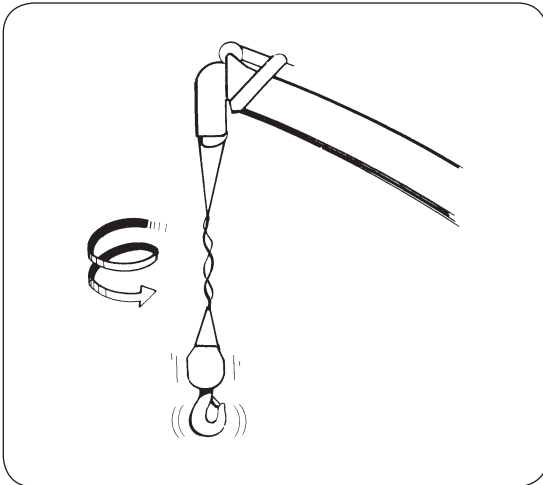

◆3. How to correct twisted wire ropes

Wire ropes tend to turn in untwisting direction when they are under tension.

If two or more wire ropes are hooked together, they tend to be twisted particularly while they are new.

The twist will decrease as the ropes are getting fit to the crane.

If wire ropes are twisted, correct them as follows:

1. Unload the hook.
2. Extend the boom fully.
3. Raise the boom to an angle of approximately 65°.
4. Unwind the hook until it comes close to the ground.
5. Check how many turns the wire rope has been twisted.
6. Wind up the hook and retract the boom to be on a stored condition.
7. Remove the wire socket and turn the socket in the untwisting direction by as many turns as the wire ropes have been twisted multiplied by the number of wire ropes being hooked.
However, remember that the wire socket may be turned up to 4 turns at a time.
8. Attach the wire socket and repeat winding up and down the rope 2 or 3 times between both extremes.
Then, check if twist of the wire ropes is corrected.
If they remain twisted, repeat the procedures shown above.

5 Replacement of expendable parts

◆1. Replacement of gaskets and seals for each cylinder

Although timing of replacement of a part varies according to how frequently the crane has been operated, replace gaskets and seals used in each cylinder after every 3 years of operation (period during which crane has not been operated is included) in order to operate the crane safely.

Ask a local UNIC authorized service shop for replacement of gaskets and/or seals.

◆2. Replacement of sliding plate of boom

Replace it every 3 years.

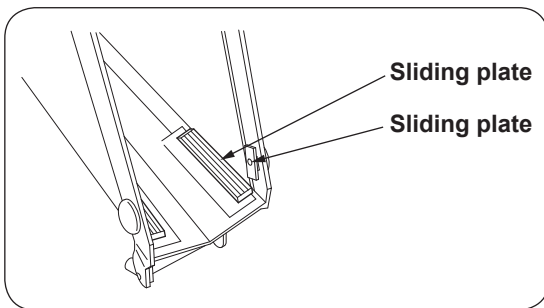

◆3. Replacement of brake shoe of hoisting winch

Replace it every 3 years.

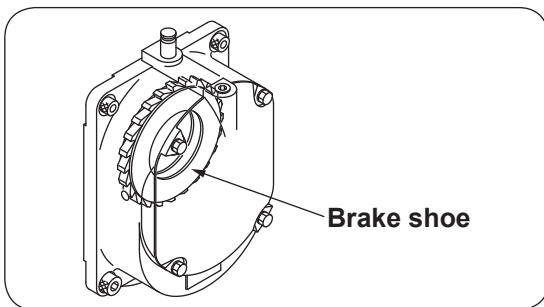

15. LUBRICATION TO CARRIER

WARNING

- ★ Be sure to stop the engine, and store the boom and the outriggers before carrying out filling/replacing lubricant and/or fuel.
- ★ A fire source such as smoking cigarette in mouth is strictly prohibited.
- ★ Do not rush to start maintenance and inspection as the engine and the members close to the engine is heated to a high temperature immediately after the engine has been stopped.

1 *Precaution when carrying out lubrication*

Lubricate according to "Lubrication chart" and keep the following instructions in mind when carrying out lubrication.

1. Clean filling ports and grease nipples thoroughly before carrying out lubrication.
2. Always supply new lubricant and prevent dusts from entering inside.
3. When supplying grease into each grease nipple, be sure to inject it until old grease is forced out of it.

CAUTION

- ★ In order to ensure smooth operation of each part of the crane, minimum wear, and longer service life, be sure to supply lubricant as well as hydraulic oil which is indispensable to drive hydraulic equipment.
- ★ Warranty will not be given, even if it is within the period to be applied, for failure to observe the replacement of lubricant as specified.

2 List of recommended lubricant

◆ 1. Use the engine oils as below:

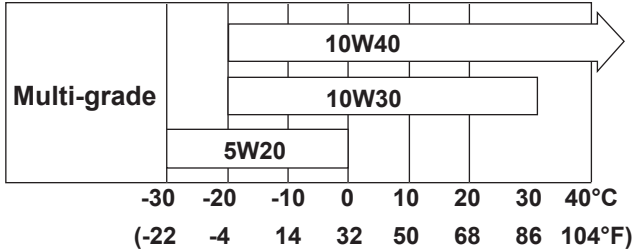

The selection of engine oil is very important to a engine. If an unsuitable oil is used, or oil change is neglected, it may result in damage, and a shorter engine life.

Use oils that meet API Engine Service Classification CD.

◆ 2. Use the recommended grease for lubrication as below.

Chassis grease

Use NLGI No. 2 grade for most temperatures.

Use NLGI No. 1 grade for extremely low temperatures.

◆ 3. Use the fuel as specified below.

Use only automobile non-leaded gasoline

◆ 4. Hydraulic oil is the same as the oil used in the crane.

◆ 5. Use the gear oils for the reduction gears of crawling motor as below:

Classification	Depending on atmospheric temperature							
	(-22	-4	14	32	50	68	86°F)	
Rating to be applied	-30	-20	-10	0	10	20	30°C	
Engine oil								
Diesel engine oil	SAE30							
of CD class								

- SHELL : DONAX TT or TD
- CALTEX : RPM TRACTOR HYDRAULIC FLUID
- CHEVRON : TRACTOR HYDRAULIC FLUID
- TEXACO : TDH OIL
- MOBIL : MOBILAND SUPER UNIVERSAL.

It is possible to substitute engine oil CLASS-CD SAE 30.

3 Lubrication chart (carrier part)

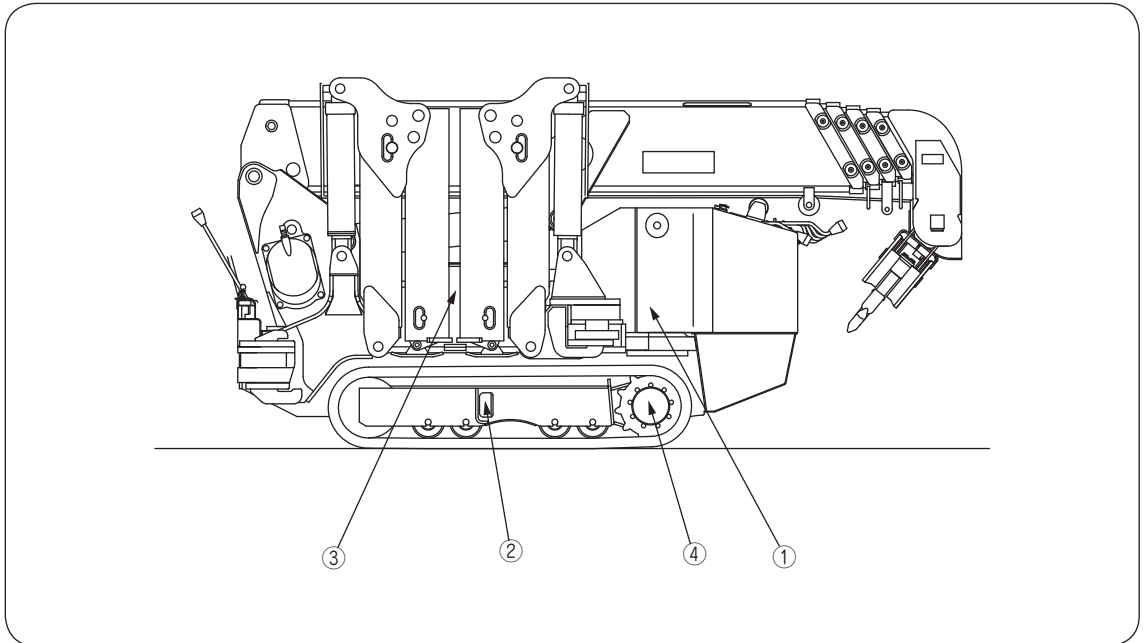

Service interval	Where to lubricate	No. of part	Lubricant	Tool
Initial: Replace after 25 hours After : Replace every 50 hours	①Engine 0.3 gal. (1.2 liters)	1	Engine oil	
Initial : 30 hours, Whenever necessary	②Tension adjustment of rubber crawler	2		1 1/4 in. (32mm) spanner
Initial: Replace after 3 months After : Replace once a year or every 500 hours	③Hydraulic oil tank 7.1 gal. (27 liters)	1	Hydraulic oil	
Replace every 1000 hours	④Reduction gears of crawling motor 0.1 gal. (0.33 liters)	2 (Right/ Left)	Diesel engine oil	

Refer to section 13 "MAINTENANCE AND INSPECTION OF CARRIER" for replacement procedures.

Fuel	Gasoline
Fuel tank capacity	1.6 gal. (6 liters)

16. LUBRICATION TO CRANE

WARNING

★ Do not carry out maintenance and inspection while temperature of hydraulic oil is still high.

★ Be sure to stop the engine to carry out lubrication.

★ Temperature of both hydraulic and gear oils is very high immediately after crane operation so that accumulated high pressure still remains inside.

Uncapping the filling port, draining oil, and replacing filter while oil temperature is high may allow the hydraulic and/or gear oils to spout out from which a scald may result.

1 *Precaution when carrying out lubrication*

Lubricate according to "Lubrication chart" and keep the following instructions in mind when carrying out lubrication.

1. Clean filling ports and grease nipples thoroughly before carrying out lubrication.
2. Always supply new lubricant and prevent dusts from entering inside.
3. When supplying grease into each grease nipple, be sure to inject it until old grease is forced out of it.

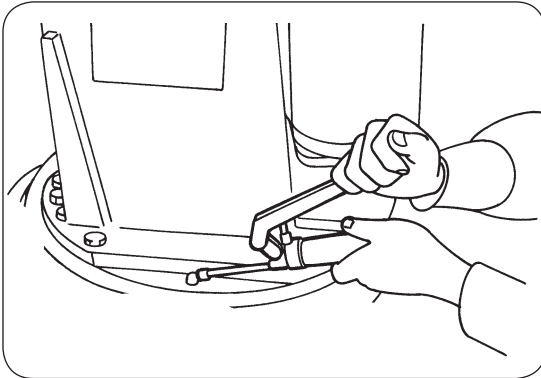

CAUTION

★ In order to ensure smooth operation of each part of the crane, minimum wear, and longer service life, be sure to supply lubricant as well as hydraulic oil which is indispensable to drive hydraulic equipment.

★ Warranty will not be given, even if it is within the period to be applied, for failure to observe the replacement of lubricant as specified.

2 List of recommended lubricant

◆1. List of recommended lubricants

★ Use the UNIC genuine hydraulic oils listed below as hydraulic oil for the crane.

Use industrial-type hydraulic oil

ISO VG 46 for temperatures above 32°F (0°C).

ISO VG 32 for temperatures below 32°F (0°C).

Petroleum Maker	Brand	
	ISO VG 32	ISO VG 46
EXXON MOBIL	Mobil DTE 24	Mobil DTE 25
CHEVRON	Rando Oil HD ISO 32	Rando Oil HD ISO 46
SHELL	Shell Tellus Oil 32	Shell Tellus Oil 46

★ Use the recommended lubricants listed below as gear oil for lubrication.

Aplication	Petroleum Maker	Brand
Reducer for winch	EXXON MOBIL	Mobil Devac Super DH-2 15W-40
	SHELL	Shell Rimula R3 X 15W-40
Reducer for slewing gear	Use API service GL-4 gear oils. (Refer to the followings)	
	CHEVRON	Thuban GL4 90
	SHELL	Shell Spirax EP 90

★ Use the recommended greases listed below as grease for lubrication.

(a) Chassis grease

Use NLGI No. 2 grade for most temperatures.

Use NLGI No. 1 grade for extremely low temperatures.

(b) Molybdenum grease

Use NLGI No. 2 grade.

Petroleum Maker	Brand
EXXON MOBIL	Mobilgrease CM-P
CHEVRON	Moly grease EP 2 (Texaco Molytex EP 2)
SHELL	Retinax grease EPX 2 (Retinax grease AM)

3 Lubrication chart (crane part)

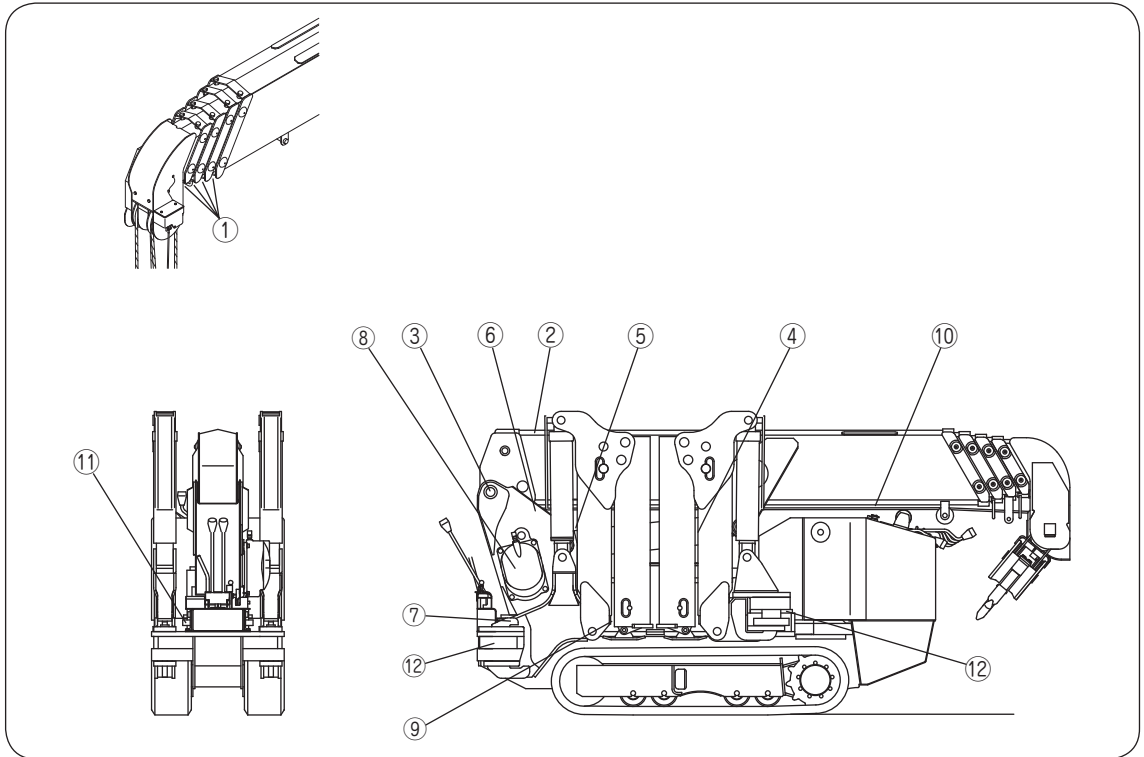

Service interval	Where to lubricate	No. of part	Lubricant	Tool
Daily	① Boom slide plate (Underside & side face of boom sections ②, ③, ④, and ⑤) For 5-section boom	4	Molybdenum grease	Manual application
	② Boom slide plate (Upper side of boom section ①)	4	Molybdenum grease	Grease pump
	③ Boom foot pin	1	Chassis grease	Grease pump
	④ Upper support pin of derrick cylinder	1	Chassis grease	Grease pump
	⑤ Lower support pin of derrick cylinder	1	Chassis grease	Grease pump
Weekly	⑥ Winch drum gears	1	Chassis grease	Grease pump
	⑦ Slewing gears	1	Chassis grease	Manual application
Monthly	⑧ Winch reduction gears Approx. 0.3 gal. (1.0 liter)	1	Gear oil	
	⑨ Slewing reduction gears Approx. 0.1 gal. (0.3 liters)	1	Gear oil	
	⑩ Wire rope	1	Rope grease	Spray gun
	⑪ Slewing bearings	2	Chassis grease	Grease pump
	⑫ Outrigger fulcrum pin	4	Chassis grease	Grease pump

4 Lubrication

◆ 1. Replacement of gear oil

(Winch reduction gears and Slewing reduction gears)

★ Air enters in and out of the gear case so that dirt and moisture are brought in the gear case.

In addition, since hydraulic equipment gradually wears to produce worn particles, replace gear oil after 6 months from the start of operation.

★ Afterward, replace gear oil:

- Once a year for winch reduction gears, and
- Once every 2 years for slewing reduction gears.



CAUTION

★ Replace gear oil after oil temperature has dropped.

★ Fill up the oil for winch reduction gears until oil level comes to halfway between upper limit and lower limit on the oil level gauge (oil quantity: approx. 0.3 gal. (1.0 liter)).

★ Fill up the oil for slewing reduction gear until oil level comes to halfway between upper limit and lower limit on the oil level gauge (oil quantity: approx. 0.1 gal (0.3 liters)).

In order to check oil level, insert the level gauge until it just touches the oil level port (not screwing it in).

Winch reduction gears

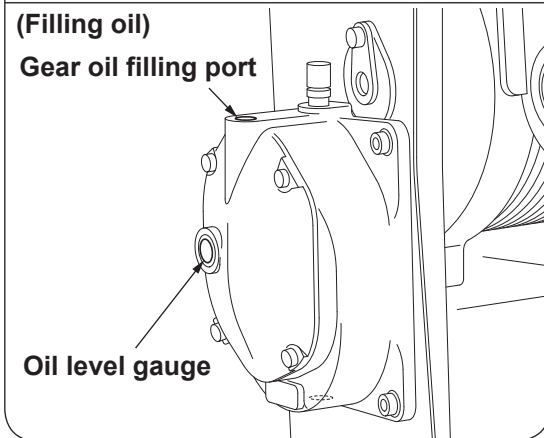
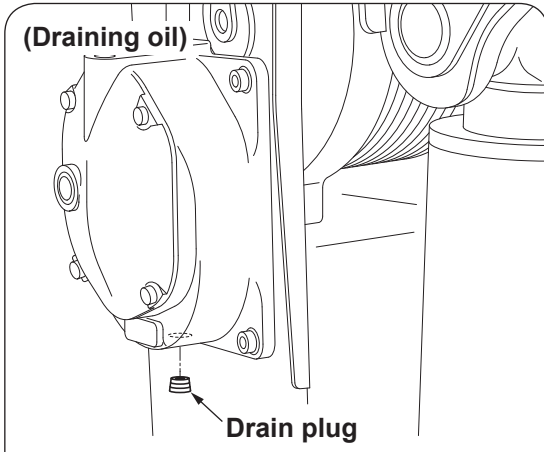

Slewing reduction gears

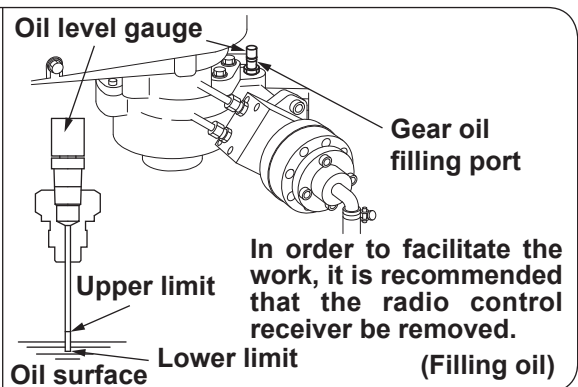
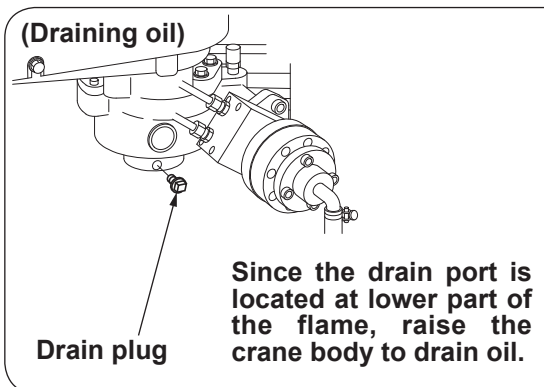

◆**2. Lubrication to slewing bearings**

The crane employs ball bearings as the slewing bearing.

Be sure to lubricate the bearings as insufficient lubrication may cause it to make unusual noise.

Grease the nipples while slewing the boom once a month for moderate operation, and once a week for heavy-duty operation.

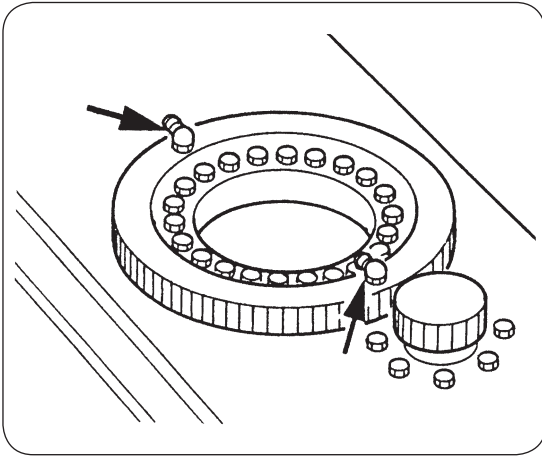

◆3. Hydraulic circuit

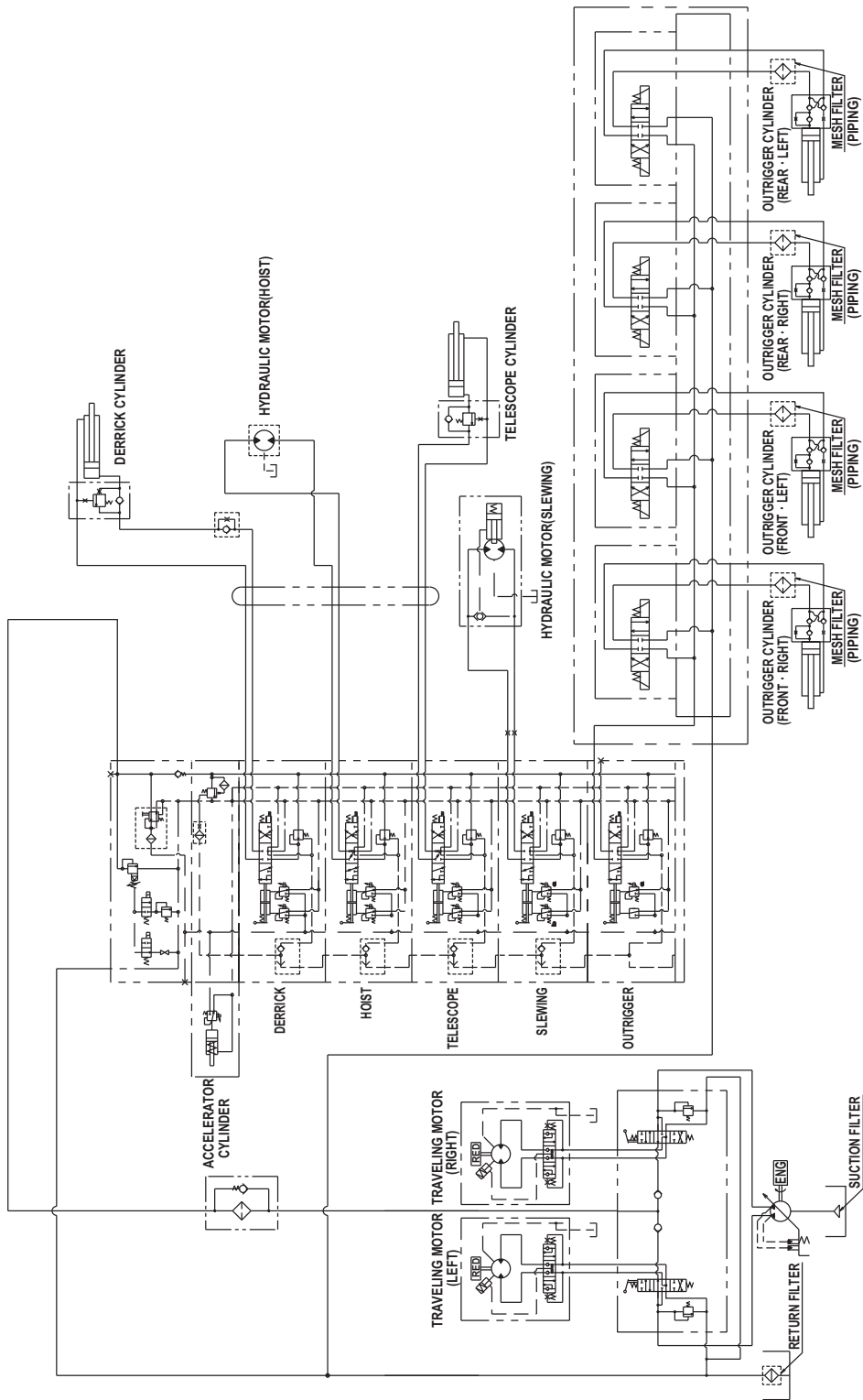

17. MAJOR SPECIFICATIONS

1 URW295CP1UR (5-section boom)

(Speed indicated in the table below is at oil temperature range of 113°F~131°F (45°C~55°C), operating with no-load, and at rated pump discharge.)

Major specifications

Model		URW295CP1UR (5-section boom)
Crane capacity (maximum lifting load)		6450 lbs. × 4.6ft (2930kg×1.4m) (With outriggers, extended fully)
Maximum lift above ground (Hook)		Approx. 28.9ft (8.8m) with 4-part line
Boom to be extended to:		8.3ft ~ 13.4ft ~ 18.4ft ~ 23.4ft ~ 28.4ft
Maximum working radius		27.6ft (8.41m)
Speed of winding-up (Rope speed)		(At 4th layer on the drum) 131.2ft (40m) /min
Hoisting speed of hook		32.8ft (10m) /min (At 4th layer on the drum, with 4-part line hooking)
Extending speed of boom		20.1ft (6.12m) /20sec
Raising speed of boom		0° ~ 78°/11sec
Slewing speed		1.5r.p.m.
Slewing range		360° (Continuous)
Hoisting rope	Construction	IWRC 6×WS (26) Class B (Breaking load: 9520 lbs {43.2kN (4400kgf)})
	Diameter×length	5/16in. (8mm)×155ft (47.5m)
Outrigger		Direct pushing by double acting hydraulic cylinder (directly connected to hydraulic automatic locking device)
Hydraulic pump	Rated pressure	Crane: 2990psi {20.6MPa (210kgf/cm ²)} Travel:3130psi {21.6MPa (220kgf/cm ²)}
	Rated discharge	Approx. 10gal. (38 l) /min
	Rated rotation	Approx. 2000rpm
Hydraulic oil tank Capacity		7.13gal. (27 liters)

MAJOR SPECIFICATIONS

Equipment and construction

Model	URW295CP1UR (5-section boom)
Boom telescoping	Boom:5-section, Hexagonal box beam
	Telescoped by direct pushing of hydraulic cylinder and by wire rope (With hydraulic automatic locking device) (2nd & 3rd sections: sequential actuation, 4th & 5th sections: simultaneous actuation)
Boom derricking	Direct pushing by hydraulic cylinder (With hydraulic automatic locking device)
Hoisting	Hydraulic motor: Axial plunger type
	Reduction gears: Spur-gear reduction
	Brake: Automatic mechanical brake
Slewing	Hydraulic motor: Trochoid type (With hydraulic automatic locking device)
	Reduction gears: Worm-gear+Spur-gear reduction (Supported by ball bearings)
	Brake: Worm self-lock
Hydraulic pump	Variable delivery piston pump
Hooking capacity	6450 lbs (2930kg) Parts of hoist reeving: 4
Safety device	Pressure relief valve for hydraulic circuit
	Hydraulic automatic lock (Counterbalance valves and pilot-operated check valves)
	Automatic stop for overwinding
	Overwinding alarm
	Alarm buzzer
	Hook safety latch
	Interlock for crane-crawl lever and outriggers
	Turnover prevention device
Level	
Weight	Approx. 4100 lbs (1850kg)

Crawling device

Model	URW295CP1UR (5-section boom)
Crawling	Endless rubber crawler
Crawler	7 1/8 (in.) ×40 links×2 7/8 (in.) FR (180 (mm)×40 links×72 (mm) FR)
Length of ground contact	3.44ft (1050mm)
Pressure of ground contact	6.96psi {48.0kPa (0.49kgf/cm ²)}
Crawling speed	Forward/Backward: 0 ~ 1.4mph (0 ~ 2.3km/h)
Hill-climbing ability	20°
Engine	Rated output 9.6kW (13hp)/2000r.p.m
Crawling	Independently driven by hydraulic power
Parking brake	Disc brake with hydraulic motor built-in
Starting engine	Electric starter
Fuel tank	Capacity: 1.58gal (6 liters)

MAJOR SPECIFICATIONS

Chart of rated load

RATED LOADS

BOOM SECTION		1 • 1+2								
WORKING RADIUS(ft)		3.0	4.5	5.0	6.0	7.0	8.0	10.0	11.0	12.58
RATED LOAD (lbs)	MAX EXT. OUTRIGGERS	6450	6450	5850	4950	4350	3800	2850	2450	2000
	NOT MAX EXT. OUTRIGGERS	4450	4450	4450	3150	2250	1600	1100	950	600

BOOM SECTION		1+2+3								
WORKING RADIUS(ft)		7.0	8.0	9.5	10.0	11.0	12.0	14.0	15.0	17.62
RATED LOAD (lbs)	MAX EXT. OUTRIGGERS	3050	3050	3050	2750	2450	2150	1650	1450	1000
	NOT MAX EXT. OUTRIGGERS	1850	1550	1250	1150	1000	850	600	550	300

BOOM SECTION		1+2+3+4								
WORKING RADIUS(ft)		11.0	12.5	13.0	15.0	16.0	17.0	18.0	20.0	22.61
RATED LOAD (lbs)	MAX EXT. OUTRIGGERS	1950	1950	1750	1350	1200	1100	1000	850	660
	NOT MAX EXT. OUTRIGGERS	1000	800	750	600	510	450	370	280	200

BOOM SECTION		1+2+3+4+5									
WORKING RADIUS(ft)		12.5	13.5	15.0	16.0	18.0	19.0	21.0	23.0	25.0	27.59
RATED LOAD (lbs)	MAX EXT. OUTRIGGERS	1280	1280	1050	920	750	700	590	500	440	350
	NOT MAX EXT. OUTRIGGERS	850	700	600	530	420	380	300	220	180	130



CAUTION

RATED LOADS

- The rated loads show the performance of the crane on level ground and are based on the actual working radiuses including the deflection of boom under load condition. The rated loads are also based on strength and stability of crane.
- "Max extended outriggers" means inner boxes are extended to the max. extended position and a swing lock pin of each outrigger arm is inserted into the normal position. Other than the above, operate according to figures of "not max ext. outriggers"
- If even one outriggers are not fully extended, operate according to the figures of "not max. ext. outriggers".
- Improper set-up of outriggers may cause a turnover of the crane. Extend outriggers fully and Place them on firm and level ground. Make sure lock pins are inserted properly.
- Boom [1+2+3+4] means boom [4] is extended up to ▼ mark.
- Operate according to the figures of [1+2+3] when boom [3] is extended even a bit. Do according to [1+2+3+4] when boom [4] is extended even a bit. Do according to [1+2+3+4+5] when ▼ mark in the side of boom [4] moves away from boom [3] even a bit.

09HQ86040-W295CUR

• **How boom-sections are extended**

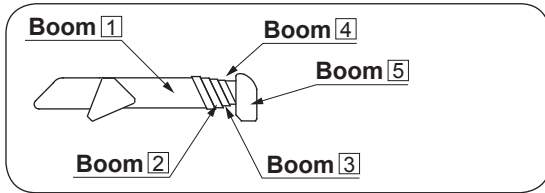

Boom **1**:
All boom sections are retracted.

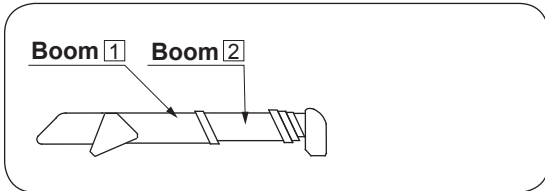

Boom **1+2** or **2**:
Boom section(2) only is extended.

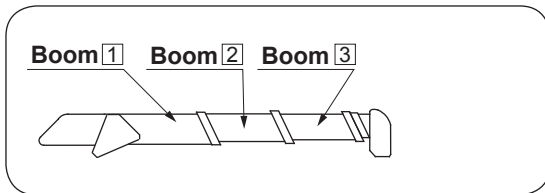

Boom **1+2+3** or **3**:
Boom sections(2) and (3) are extended.

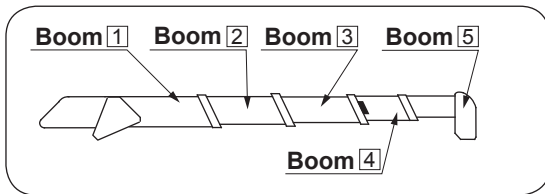

Boom **1+2+3+4** or **4**:
Boom section(4) is extended to the mark \ .

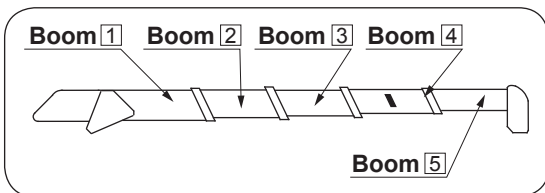

Boom **1+2+3+4+5** or **5**:
Boom-sections(2), (3), (4), and (5) are fully extended.

MAJOR SPECIFICATIONS

2 URW295SCP1UR (5-section boom)

(Speed indicated in the table below is at oil temperature range of 113°F~131°F (45°C~55°C), operating with no-load, and at rated pump discharge.)

Major specifications

Model		URW295SCP1UR (5-section boom)
Crane capacity (maximum lifting load)		1990 lbs. × 12.5ft (900kg×3.8m) (With outriggers, extended fully)
Maximum lift above ground (Hook)		Approx. 25.5ft (7.76m) with 2-part line
Boom to be extended to:		8.3ft ~ 13.4ft ~ 18.4ft ~ 23.4ft ~ 24.9ft
Maximum working radius		24.1ft (7.35m)
Speed of winding-up (Rope speed)		(At 4th layer on the drum) 131.2ft (40m) /min
Hoisting speed of hook		65.6ft (20m) /min (At 4th layer on the drum, with 2-part line hooking)
Extending speed of boom		16.6ft (5.06m) /18sec
Raising speed of boom		0° ~ 78°/11sec
Slewing speed		1.5r.p.m.
Slewing range		360° (Continuous)
Hoisting rope	Construction	IWRC 6×WS (26) Class B (Breaking load: 9520 lbs {43.2kN (4400kgf)})
	Diameter×length	5/16in. (8mm)×155ft (47.5m)
Outrigger		Direct pushing by double acting hydraulic cylinder (directly connected to hydraulic automatic locking device)
Hydraulic pump	Rated pressure	Crane: 2990psi {20.6MPa (210kgf/cm ²)} Travel: 3130psi {21.6MPa (220kgf/cm ²)}
	Rated discharge	Approx. 10gal. (38 l) /min
	Rated rotation	Approx. 2000rpm
Hydraulic oil tank Capacity		7.13gal. (27 liters)

Equipment and construction

Model	URW295SCP1UR (5-section boom)
Boom telescoping	Boom:5-section, Hexagonal box beam
	Telescoped by direct pushing of hydraulic cylinder and by wire rope (With hydraulic automatic locking device) (2nd & 3rd sections: sequential actuation, 4th & 5th sections: simultaneous actuation)
Boom derricking	Direct pushing by hydraulic cylinder (With hydraulic automatic locking device)
Hoisting	Hydraulic motor: Axial plunger type
	Reduction gears: Spur-gear reduction
	Brake: Automatic mechanical brake
Slewing	Hydraulic motor: Trochoid type (With hydraulic automatic locking device)
	Reduction gears: Worm-gear+Spur-gear reduction (Supported by ball bearings)
	Brake: Worm self-lock
Hydraulic pump	Variable delivery piston pump
Hooking capacity	1955 lbs (885kg) Parts of hoist reeving: 2
Safety device	Pressure relief valve for hydraulic circuit
	Hydraulic automatic lock (Counterbalance valves and pilot-operated check valves)
	Automatic stop for overwinding
	Overwinding alarm
	Alarm buzzer
	Hook safety latch
	Interlock for crane-crawl lever and outriggers
	Turn over prevention device
Level	
Weight	Approx. 4100 lbs (1850kg)

MAJOR SPECIFICATIONS

Crawling device

Model	URW295SCP1UR (5-section boom)
Crawling	Endless rubber crawler
Crawler	7 1/8 (in.) ×40 links×2 7/8 (in.) FR (180 (mm)×40 links×72 (mm) FR)
Length of ground contact	3.44ft (1050mm)
Pressure of ground contact	6.96psi {48.0kPa (0.49kgf/cm ²)}
Crawling speed	Forward/Backward: 0 ~ 1.4mph (0 ~ 2.3km/h)
Hill-climbing ability	20°
Engine	Rated output 9.6kW (13hp)/2000r.p.m
Crawling	Independently driven by hydraulic power
Parking brake	Disc brake with hydraulic motor built-in
Starting engine	Electric starter
Fuel tank	Capacity: 1.58gal (6 liters)

Chart of rated load

RATED LOADS

The mass of the hook(35lbs.),slings, and any accessories attached to the boom or loadline must be deducted from the rated loads in the chart.

BOOM SECTION		1		1+2									
WORKING RADIUS(ft.)		3.0	4.5	5.0	6.0	7.0	7.4	8.0	10.0	11.0	12.58		
RATED LOAD (lbs.)	MAX.EXT. OUTRIGGERS	1990	1990	1990	1990	1990	1990	1990	1990	1990	1990		
	NOT MAX EXT OUTRIGGERS	1990	1990	1990	1990	1990	1990	1600	1100	950	600		

BOOM SECTION		1+2+3											
WORKING RADIUS(ft.)		7.0	8.0	9.5	10.0	11.0	12.0	12.5	14.0	15.0	17.62		
RATED LOAD (lbs.)	MAX.EXT. OUTRIGGERS	1990	1990	1990	1990	1990	1990	1990	1650	1450	1000		
	NOT MAX EXT OUTRIGGERS	1850	1550	1250	1150	1000	850	780	600	550	300		

BOOM SECTION		1+2+3+4											
WORKING RADIUS(ft.)		11.0	12.5	13.0	15.0	16.0	17.0	18.0	20.0	22.61			
RATED LOAD (lbs.)	MAX.EXT. OUTRIGGERS	1950	1950	1750	1350	1200	1100	1000	850	660			
	NOT MAX EXT OUTRIGGERS	1000	800	750	600	510	450	370	280	200			

BOOM SECTION		1+2+3+4+5											
WORKING RADIUS(ft.)		12.5	13.5	15.0	16.0	18.0	19.0	21.0	23.0	24.1			
RATED LOAD (lbs.)	MAX.EXT. OUTRIGGERS	1280	1280	1050	920	750	700	590	500	460			
	NOT MAX EXT OUTRIGGERS	850	700	600	530	420	380	300	220	200			



CAUTION RATED LOADS

- The rated loads show the performance of the crane on level ground and are based on the actual working radiuses including the deflection of boom under load condition. The rated loads are also based on strength and stability of crane.
- "Max. extended outriggers" means inner boxes are extended to the max. extended position and a swing lock pin of each outrigger arm is inserted into the normal position. Other than the above, operate according to figures of "not max. ext. outriggers".
- If even one outriggers are not fully extended, operate according to the figures of "not max. ext. outriggers".
- Improper set-up of outriggers may cause a turn over of the crane. Extend outriggers fully and place them on firm and level ground. Make sure lock pins are inserted properly.
- Boom [1+2+3+4] means boom [4] is extended up to mark.
- Operate according to the figures of [1+2+3] when boom [3] is extended even a bit. Do according to [1+2+3+4] when boom [4] is extended even a bit. Do according to [1+2+3+4+5] when mark in the side of boom [4] moves away from boom [3] even a bit.

30KJ86040-W295SCP1UR

MAJOR SPECIFICATIONS

• How boom-sections are extended

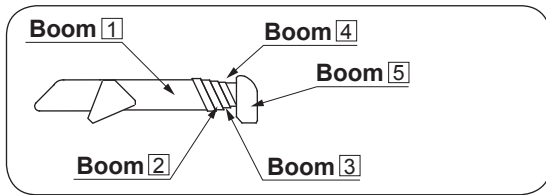

Boom **1**:
All boom sections are retracted.

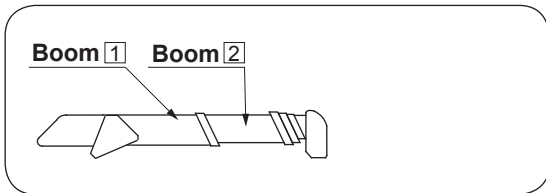

Boom **1+2** or **2**:
Boom section(2) only is extended.

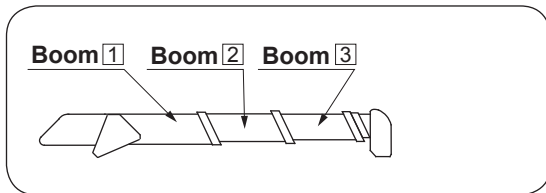

Boom **1+2+3** or **3**:
Boom sections(2) and (3) are extended.

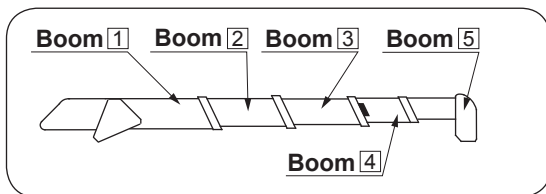

Boom **1+2+3+4** or **4**:
Boom section(4) is extended to the mark **▲**.

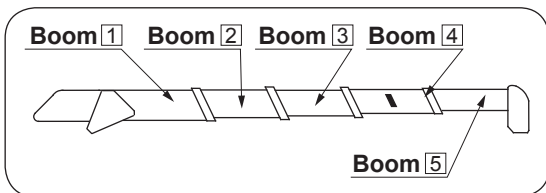

Boom **1+2+3+4+5** or **5**:
Boom-sections(2), (3), (4), and (5) are fully extended.

3 Major specification (Radio remote control device)

Model	RC-500HA-USA, Radio remote control device	
Radio frequency	458~459 MHz band	
Transmission output	10 mW	
Frequency selection	Auto-scanning system	
Range of radio wave	100m min. (when in good conditions)	
System structure	Combined system of manual and radio remote control operation	
Controls (functions operated through radio control transmitter)	Selector switches : Boom :Up/Down (Hook RELEASE) Outrigger ④ Ret/Ext Hook :Up/Down (Shock-less ON/OFF) Outrigger ③ Ret/Ext Boom telescoping:Extend/Retract Outrigger ② Ret/Ext Slewing :C.C.W./C.W. (Start/Stop) Outrigger ① Ret/Ext	
	Store hook :Storage Speed selector switch : Switching to mode of :High/Medium/Low speed Mode switch :Switching each function by combination of selector switch Horn switch :Alarm/Start Speed lever :Both hydraulic control and engine speed control	
Power supply	Crane: Crawler battery (DC 12V) Transmitter: a size AAA battery: 4 pieces	
Power consumption	Crane operating single function at maximum speed: Approx. 50W, 120W max. (including control box) Transmitter (service life with alkaline batteries): 20 hours min.	
Voice messages	"Crane mode" "Outrigger mode, outriggers moving" "Secure lifting hook" "Service remote control"	"Remote control ready" "Stop winch up" "Low transmitter battery" "Change control mode"
Operating temperature range	-4°F~+140°F (-20°C~+60°C)	
Storing temperature range	-22°F~+167°F (-30°C~+75°C)	
Weight of transmitter	1.5 lbs (700g) (including batteries)	

★ The radio remote control device employs a unique data transmission system and an ID (identification) code is assigned to each equipment.

Therefore, the crane will not be worked by radio wave radiated from other radio equipment.

★ About auto-scanning system :

Auto-scanning system is a system that changes the current frequency to other frequencies automatically to avoid radio interference when a similar radio wave is being radiated nearby.

18. MODE INDICATOR LAMP (Control Box)

1 Mode indicator lamp (Control box)

The "mode indicator lamp" is mounted in the control box indicating conditions of crane operation and troubles in detail.

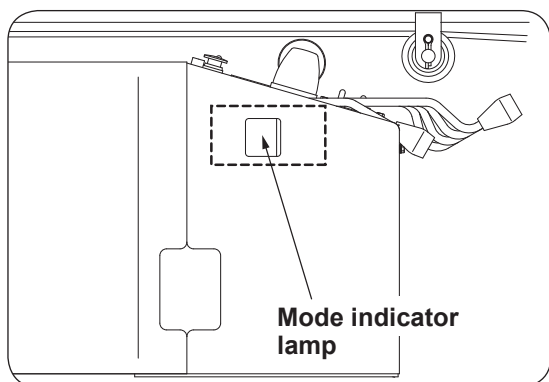

When the "mode indicator lamp" lights, the crane system is working normally.

When the "mode indicator lamp" blinks, the crane system is in a trouble or prohibited operation is being carried out.

◆1. Mode indication when crane is in normal operation

It indicates each operation mode and condition of the crane when it is normal.

Description of mode indication when it is in normal is as follows:

Mode indication when crane is in normal condition (lighting indication)

Mode	Mode description	Radio control operation mode	Manual operation mode	Priority
0F	Current control is on traveling mode. No operation other than traveling is possible either by manual control or by radio remote control.	×	×	1
00	Current control is on normal crane operation mode. Operation is possible either by manual control or by radio remote control.	○	×	9
01.	Current control is on normal crane operation mode. Operation can only be carried out manually but not through radio remote control device.	×	○	9
04 05	Current operation is in outrigger radio control mode. Extension and retraction of outriggers can only be possible by manual control when in manual control mode or by radio remote control when in radio remote control mode. Operation other than the above is impossible either by manual or by radio remote control.	○	×	5
		×	○	
06	Current control is on low temperature operation mode. Operation can be carried either by manual control or by radio remote control device.	(○)	(○)	8

MODE INDICATOR LAMP (CONTROL BOX)

Mode	Mode description	Radio control operation mode	Manual operation mode	Priority
07.	Current control is on low temperature operation mode. Operation can be carried by manual control but not through radio remote control.	×	○	8
10	Hook hits against weight for over-winding alarm (over-wound condition).	—	—	7
13	During operation of storing hook.	—	—	6
14	Automatic stop for overwinding reset switch is being controlled.	—	—	4
15	<ul style="list-style-type: none"> • Outriggers fail to touch the ground or overturn threshold alarm is actuated. • Automatic stop of the boom storing. 	—	—	2
16	<ul style="list-style-type: none"> • Outriggers fail to be set up on the ground securely or overturn prediction alarm is actuated. • Crane operating speed is slowly. 	—	—	3

● Remarks

Since priority is assigned for each mode description, it is to be indicated in the order of higher priority.

If the [.] (dot) is indicated on the bottom right of "mode indicator lamp", it means the "radio control OFF" mode.

Crane cannot be operated through radio control transmitter.

When operated on outrigger radio control mode, crane operation other than extension/retraction of outriggers cannot be carried out.

When the shock-less function has been cancelled, the letter on the left indicated in the mode indicator changes to [-].

Refer to page 12-23 for detail.

◆2. Mode indication when crane is in trouble

When the "mode indicator lamp" is blinking figures larger than [42] (or [54] lights), the crane system is in trouble (system trouble indication).

If the system trouble indication is found on the "mode indicator lamp", confirm and follow the mode description on the table illustrated below:

If the crane becomes impossible to be operated, store the crane by following procedures described in section 12. [8] "◆5. Operation in an emergency" (on page 12-41), and ask an authorized UNIC service shop for repair.

Mode description when crane is in trouble (Blinking indication)

Mode	Mode description	Radio control operation mode	Manual operation mode
42~46	No operation is possible either by radio control or by manual control.	×	×
47~50	Turn OFF power once then turn it ON. If the trouble persists, ask an authorized UNIC service shop for repair. (Although it can be operated either by radio control or by manually, shock-less function returns to be "active".)	○	○
51~53	No radio control operation is possible.	×	○
54 (Lights)	Radio control receiver is not connected. Check that cable connector (located inside switch box) of receiver is securely connected. Check cable to receiver for damage and break.	×	○
55	Either "mode selector switch", "hook storing switch" or "radio control selector switch" in the control box is faulty. (Failed switch cannot be controlled but crane operation is possible.)	○	○
56	No operation is possible either by radio control or by manual control.	×	×
57	No operation is possible either by radio control or by manual control. Turn OFF power once then turn it ON again.	×	×
58	Radio control operation cannot be possible and engine speed control and safety devices will not function.	×	○
59	"Emergency stop switch" has been depressed. If this is indicated even when the "emergency stop switch" has not been depressed, ask a UNIC service shop for repair.	×	×

MODE INDICATOR LAMP (CONTROL BOX)

Mode	Mode description	Radio control operation mode	Manual operation mode
60~65	Manual lever is not at its neutral position when power is turned ON. Do not operate the crane as it is carrying out system diagnosis for about 2 seconds after power has been turned ON. If this appears even when the crane has not been operated, ask an authorized UNIC service shop for repair.	×	×
66~69	Either one of "Outrigger control switches" in switch panel of the crane is in failure. (Failed switch cannot be controlled but crane operation is possible.)	○	○
70~74	Stop radio control operation to try controlling levers manually. Check that the manual control levers make a smooth movement and that any of levers will not interfere with anything. If indication fails to return to be normal, ask an authorized UNIC service shop for repair.	×	×
75	Engine speed control is not carried out correctly. Crane can be operated but if this appears more frequently, ask an authorized UNIC service shop for repair.	○	○
76~79	No radio control operation is possible.	×	○
80~85	No operation is possible either by radio control or by manual control.	×	×
98	Capacity of batteries has been dropped. Try actuating reset switch in the control box to reset it once. If the trouble persists, ask a UNIC authorized service shop for repair. Replace old batteries with new ones as capacity of them has already been dropped.	×	×
99	Batteries of radio control transmitter are running out. Replace old batteries with new ones and turn OFF power once then turn it ON again.	○	○

◆3. Mode indication when crane is mistakenly operated

When prohibited operation or combination of operation which may invites dangerous situations has been carried out, the "mode indicator lamp" will blink corresponding numbers (operation error indication).

When the operation error is indicated, the "mode indicator lamp" blinks showing corresponding numbers accordingly.

Confirm and follow the mode description concerned on the table illustrated below:

● Remarks

The operation error indication is not to indicate that the crane system is in trouble.
The error indication is to be reset when stopping the operation concerned.

Mode description when crane is mistakenly operated (Blinking indication)

Mode	Description of wrong operation	Measures to be taken
01	Radio remote control operation is carried out in manual control mode. ●Mode indicator lamp located on the top of cover will not be lit when in manual control mode.	Radio remote control cannot be carried out in manual control mode. When operating with radio remote controller, turn the selector switch located on the top of cover to radio remote control mode. ●Mode indicator lamp located on the top of cover will be lit when in radio remote control mode.
04	Crane is being operated when in outrigger mode.	Crane cannot be operated when in outrigger control mode. When operating crane, turn the mode selector switch to "crane" to select crane mode.
	Crane and outriggers are operated simultaneously.	When crane and outriggers are operated simultaneously, both operating functions are stopped automatically to avoid a risk. Stop the simultaneous operation once and carry out either one of operation.
06	"Low temperature operation mode" is being switched during crane operation.	In order to avoid a risk, "low temperature operation mode" cannot be switched during crane operation. Stop crane operation once to switch it to "low temperature operation mode". For switching "low temperature operation mode", refer to section 12 8. "◆6. How to operate when engine speed becomes unstable due to low temperature" (on page 12-32).

MODE INDICATOR LAMP (CONTROL BOX)

Mode	Description of wrong operation	Measures to be taken
10	Either one of operation such as "boom Up", "hook Up", or "boom Extend" (when operated on para-hook mode) is being carried out while hook has hit against weight for over-winding alarm.	Detach hook from weight for over-winding alarm. <ul style="list-style-type: none"> ●When raising boom through radio control device with hook hit against the weight for over-winding alarm, boom is to be "Up" while hook is winding "Down" as this operation allows hook to be released. Do not lift up a cargo while this is being indicated.
90	Emergency stop switch on the remote control device is pressed.	Release the Emergency stop switch when operating crane.
96	Operation of winding down hook is carried out while the sensor detecting minimum wire rope is being activated.	Stop winding down hook and wind it up so that the sensor detecting minimum wire rope will not be activated.

19. MEASURES TO BE TAKEN IN AN EMERGENCY

1 Measures to be taken in an emergency

The "mode indicator lamp" is mounted in the control box indicating conditions of crane operation and troubles in detail.

Trouble	Possible cause	Measures to be taken
Crane fails to be operated by radio remote control device.	Batteries in transmitter have been run out or they are not loaded.	Replace batteries in transmitter.
Crane works just when a selector switch on transmitter is actuated.	Speed lever of radio control transmitter is faulty.	Repair radio control transmitter at a UNIC authorized service shop.
Crane works arbitrarily even when no controls have been made or a manual control lever has been shifted.	A solenoid valve of control valve is in failure.	Depress EMERGENCY stop switch to stop crane operation immediately. Tighten the emergency screw clockwise lightly to its extreme. (Pay attention that the screw may break if it is tightened with an excessive force.) Depress EMERGENCY stop switch again to reset emergency stop. Check that crane does not work when no controls have been made. Store crane with manual levers and ask a UNIC authorized service shop for replacement of faulty solenoid valve.

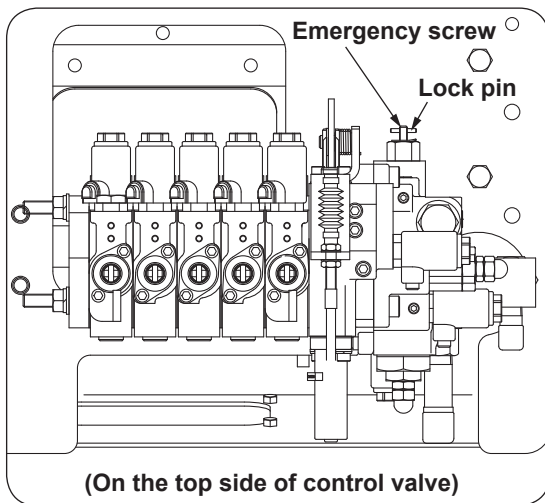

● Remarks

The emergency screw is fixed with a lock pin.
Remove the lock pin before turning the emergency screw.

FURUKAWA UNIC CORPORATION

HEAD OFFICE : Nihonbashi nishikawa Bldg, 5-3, Nihonbashi
1-chome, Chuo-ku, Tokyo 103-0027, Japan